

SARRIA-SAKAN

Instruction Book



LACUNZA®

Lacunza congratulates you on your choice.
Certified under ISO 9001, Lacunza guarantees the quality of its appliances and undertakes to meet the needs of its customers.

Confident of the know-how afforded by more than 50 years' experience, Lacunza uses advanced technologies in the design and manufacture of its entire range of appliances. This document will help you install and use your appliance in optimum conditions for your comfort and safety.

CONTENTS

1. PRESENTATION OF THE APPLIANCE	3
1.1. General characteristics.....	3
2. INSTRUCTIONS FOR THE INSTALLER.....	7
2.1. Warning to installers.....	7
2.2. Room for installation.....	7
2.2.1. Ventilation of the room.....	7
2.2.2. Location of the appliance in the room.....	8
2.3. Installation of the appliance.....	8
2.3.1. Floor.....	8
2.3.2. Safety distances.....	8
2.3.3. Checks before lighting for the first time.....	8
2.3.4. Height adjustment and levelling the appliance.....	8
2.3.5. Casing.....	8
2.3.6. Connection to the flue.....	10
2.3.7. Plus Option (Sarria Sakan 12-16).....	10
2.4. Chimney flue.....	10
2.4.1. Type of flue.....	10
2.4.2. Chimney crown.....	11
2.5. Water system.....	12
2.5.1. Obligatory parts.....	12
2.5.1.1. Expansion tank.....	12
2.5.1.2. Temperature relief valve.....	12
2.5.1.3. Pressure relief valve.....	12
2.5.1.4. Automatic fill system.....	12
2.5.1.5. Circulation pump.....	13
2.5.1.6. Pump on/off thermostat.....	13
2.5.1.7. Anti-condensation system.....	13
2.5.1.8. Automatic purge valves.....	13
2.5.1.9. Circuit drain valve.....	13
2.5.1.10. Excess heat discharge.....	13
2.5.1.11. Safety coil.....	13
2.5.2. Relationship between the output of the central-heating appliance and radiator output.....	14
2.5.3. KIT COMBI and BASIC. Combined central-heating appliance + gas/heating-oil boiler installation.....	14



2.5.4. Checking the watertightness of the system	14
2.5.5. Connecting the back boiler to the central-heating circuit	14
2.5.6. Electrolytic corrosion.....	15
2.5.7. Guideline water system diagrams	16
3. INSTRUCTIONS OF USE	20
3.1. Fuel.....	20
3.2. Description of the parts of the appliance	21
3.2.1. Operating components	21
3.3. Lighting.....	22
3.4. Loading fuel	22
3.5. Operation	22
3.6. Removing ash	23
3.7. Deflectors.....	23
4. MAINTENANCE AND IMPORTANT ADVICE.....	25
4.1. Maintenance of the appliance.....	25
4.1.1. Firebox	25
4.1.2. Inside the appliance	25
4.1.3. Painted sheet-steel-cast-iron parts	25
4.1.4. Firebox glass.....	25
4.2. Maintenance of the chimney flue.....	25
4.3. Important advice.....	26
5. TROUBLESHOOTING.....	27
6. BASIC BREAKDOWNS	28
7. PRODUCT RECYCLING.....	32
8. DECLARATION OF PERFORMANCE	33
9. CE MARK.....	43

1. PRESENTATION OF THE APPLIANCE

For optimum operation of the appliance, we advise you to read this manual carefully before switching on the appliance for the first time. In case of problems or concerns, we urge you to contact your dealer, who will cooperate with you.

In order to improve the product, the manufacturer reserves the right to make changes without notice by updating this document.

This appliance is designed to burn wood in absolutely safe conditions.

WARNING: Faulty installation may have serious consequences.

Installation and all necessary regular maintenance operations must be performed by an authorized installer in full accordance with the specifications set out in the legislation applicable in each country and this instruction book.

1.1. General characteristics

	Unit	Sarria 12	Sarria 16 Sakan 16	Sarria 20 Sakan 20	
Operating appliance	-	Intermittent	Intermittent	Intermittent	
Appliance classification	-	Type B	Type B	Type B	
Preferred fuel	-	Wood logs (Humidity<25%)	Wood logs (Humidity<25%)	Wood logs (Humidity<25%)	
Indirect heating functionality	-	YES	YES	YES	
Values at Nominal Output	Nominal output to atmosphere (Direct) (P_{nom})	kW	2.5	3	6.6
	Nominal output to water (Indirect) (P_{Vnom})	kW	12	16	13.4
	Nominal output ($P_{nom} + P_{Vnom}$)	kW	14.5	19	20
	Efficiency at P_{nom} (η_{nom})	%	80	80	81
	CO emission at 13% O ₂ at P_{nom} (CO_{nom})	mg/m ³	875	1000	901
	NO _x emission at 13% O ₂ at P_{nom} (NO_{xnom})	mg/m ³	132	122	117
	OGC emission at 13% O ₂ at P_{nom} (OGC_{nom})	mg/m ³	64	101	55
	PM emission at 13% O ₂ at P_{nom} (PM_{nom})	mg/m ³	21	25	35
	Optimum flue draught at P_{nom} (p_{nom})	Pa	12	12	12
	Gas temperature of flue at P_{nom} (T_{nom})	°C	251	250	260
	Gas temperature on the flue socket flange at P_{nom}	°C	284	289	312
	Log load frequency at P_{nom}	h	1	1	1
	Gas mass flow at P_{nom}	g/s	13.1	18	16.2
	Wood consumption (beech) at P_{nom}	kg/h	3.8	4.9	6.1
Chimney temperature class	-	T400	T400	T400	
Maximum admissible water service temperature	°C	90	90	90	
Maximum operating pressure (water)	Bar	2.1	2.1	2.1	
Back boiler capacity	L	24	34	55	
Dimensions of the firebox					
Width	mm	568	568	607	
Depth	mm	430	430	410	
Useful height	mm	330	330	330	
Maximum length of the logs	cm	50	50	60	
Volume heated (45W/m ³) at P_{nom}	m ³	322	422	444	

Capacity of the ashpit	L	2.5	2.5	2.4
Weight	kg	182	215	220
Flue socket diameter (d _{out})	mm	200	200	200
Type of heat output/room temperature control	Single stage heat output, no room temperature control			
Energy efficiency class	-	A	A	A+
Energy efficiency index (EEI)	-	106	106	107
Seasonal Energy Efficiency of space heating (η _s)	%	70	70	71

Note: The values indicated in the above table are based on tests performed in accordance with, UNE-EN 13229 and EN-16510, with logs with no more than 18% humidity and pressure conditions as indicated in each case.

Warning: this appliance is designed and prepared to work with the types of fuel, degree of humidity of the fuel, fuel loads, fuel load frequencies, flue draught and system of installation indicated in this Instruction Book. Failure to respect these conditions may lead to problems with the appliance (deterioration, shorter useful life, etc.) which are not covered by the Lacunza warranty.

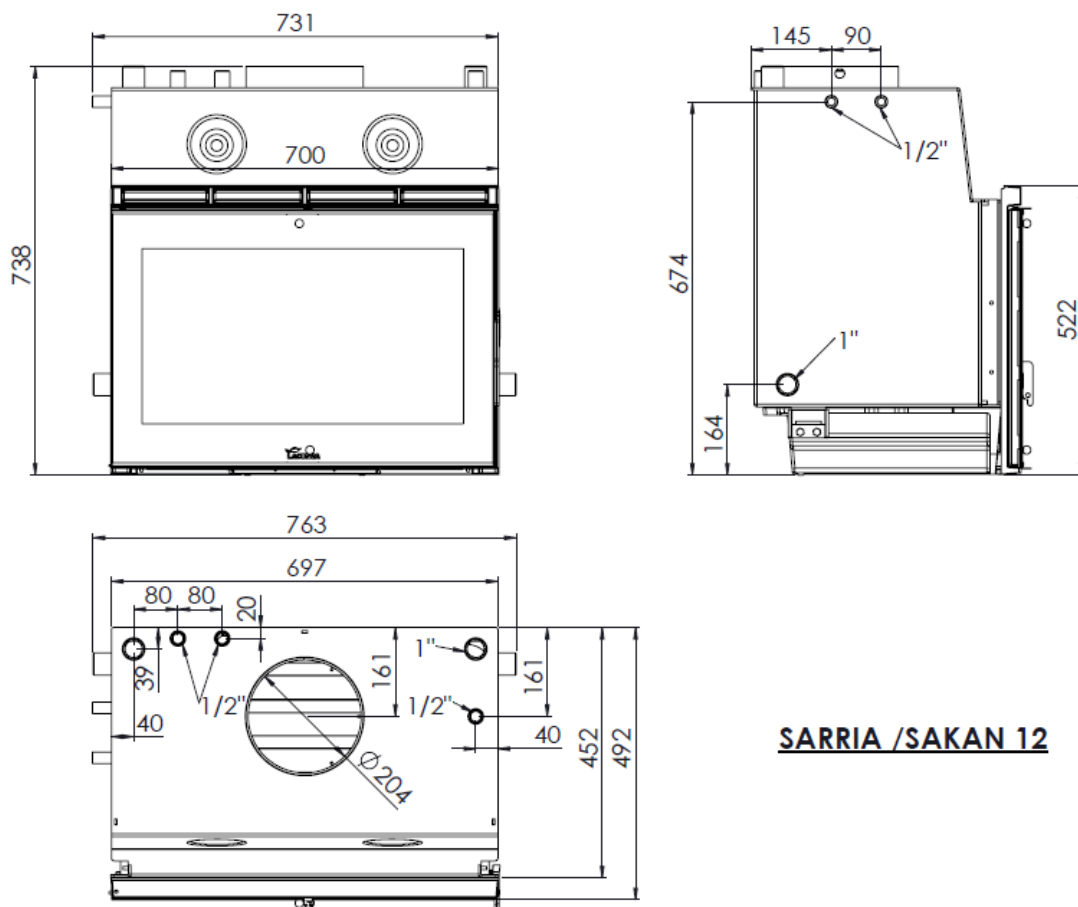

SARRIA / SAKAN 12

Figure No.1- Dimensions of the SARRIA SAKAN 12 appliance in mm

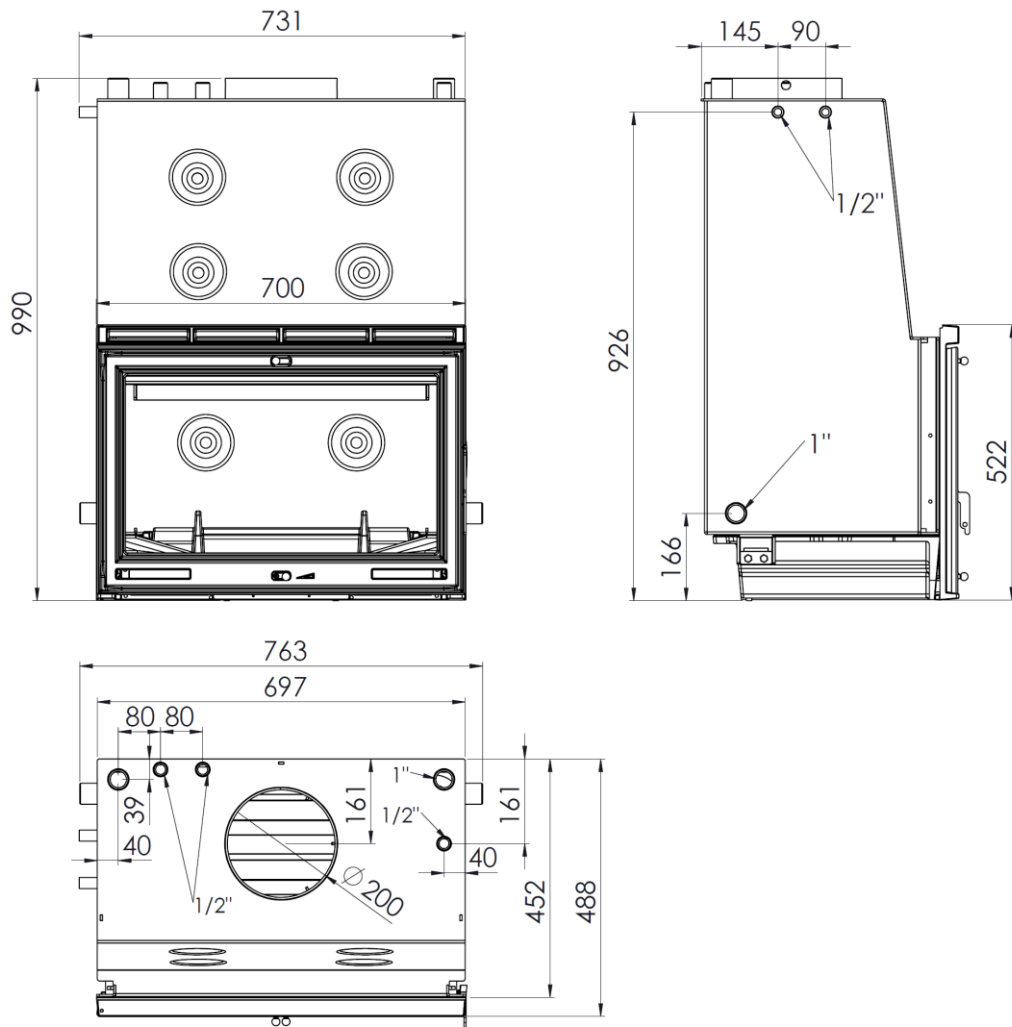

Figure No.2 - Dimensions of the SARRIA SAKAN 16 appliance in mm

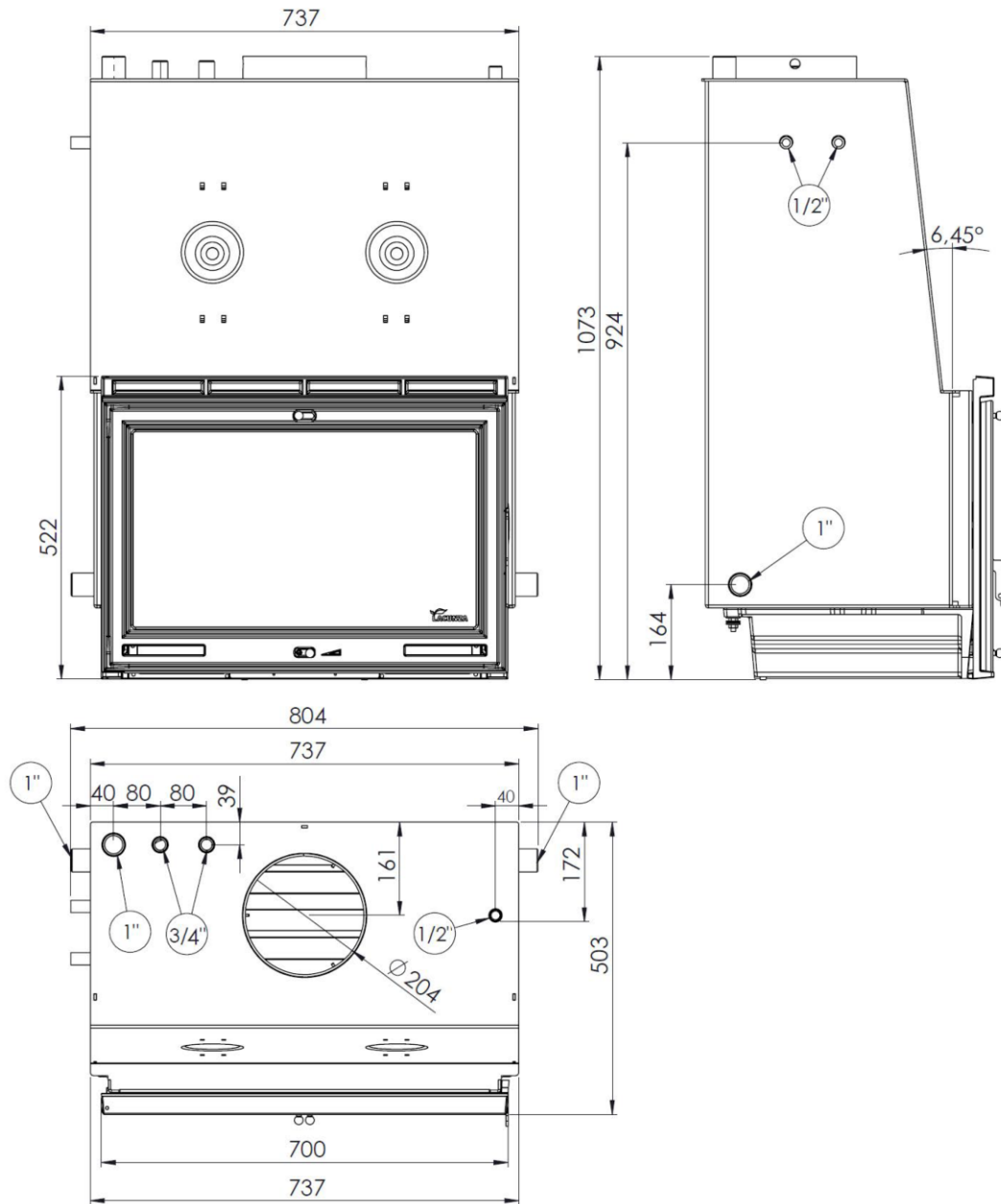

Figure No.3 - Dimensions of the SARRIA SAKAN 20 appliance in mm

2. INSTRUCTIONS FOR THE INSTALLER

2.1. Warning to installers

All local and national regulations, including all those referring to national and European standards, must be observed when installing the appliance.

Installation of the appliance must be performed by an authorised installer.

An incorrectly installed appliance may lead to serious incidents (fires, creation of harmful gases, deterioration of nearby fixtures, etc.).

Lacunza's liability is limited to the supply of the material and does not include installation of the appliance.

2.2. Room for installation

2.2.1. Ventilation of the room

The appliance needs to consume oxygen (air) in order to work properly. Ensure a suitable air supply in the room in which the appliance is fitted. This quantity of oxygen is additional to the oxygen that we need in order to breathe (air renewal).

In order to ensure the high quality of the air you breathe and to avoid potential accidents resulting from high concentrations of the gases produced by combustion (mainly carbon dioxide and carbon monoxide), it is absolutely crucial to ensure the suitable renewal of the air in the room in which the appliance is fitted.

the room must always have at least two permanent grilles or openings to the exterior in order to renew the air (one for intake and the other for extraction).

For the installation of its appliances, Lacunza recommends an additional section for these openings. One of these two grilles must be situated high up in the room (at less than 30 cm from the ceiling)

and the other one low down (at less than 30 cm from the floor). Both grilles must open outdoors in order to renew the air in the room with fresh air.

The air inlet grilles must be positioned so that they cannot be blocked or closed accidentally.

The minimum section that each of these grilles must have depends on the nominal output of the appliance in accordance with the following table:

Output of the appliance (kW)	Minimum additional section of each of the grilles (cm ²)
$P \leq 10\text{kW}$	70
$10 < P \leq 15$	90
$15 < P \leq 20$	120
$20 < P \leq 25$	150
$25 < P \leq 30$	180
$30 < P \leq 35$	210
$P > 35$	240

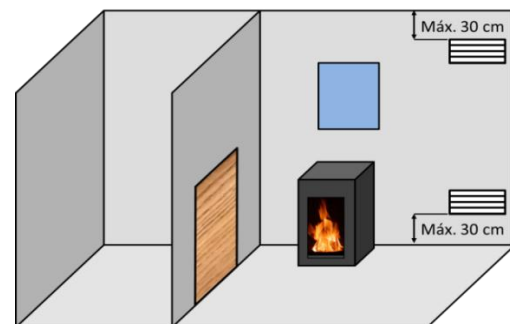

Figure No.4 - Guideline indications for ventilation grilles

The appliance must always be used with the door closed.

In rooms equipped with Controlled Mechanical Ventilation, the system extracts and renews the ambient air; in such cases, the room is at slightly low pressure and it is necessary to install a non-closable outside-air inlet with a section of at least 90 cm².

2.2.2. Location of the appliance in the room

Choose a location in the room which favours good hot-air distribution by convection and radiation.

2.3. Installation of the appliance

2.3.1. Floor

Make sure that the base can withstand the total constructed weight of the appliance and its casing.

When the floor surface (base) is combustible, fit suitable insulation.

2.3.2. Safety distances

Be sure to respect the appliance installation distances from **combustible materials**. Looking at the appliance head-on:

SARRIA SAKAN 12

	Distance to combustible materials (mm)
From the right-hand side	200
From the left-hand side	200
From the rear	200
From the front	1100

SARRIA SAKAN 16

	Distance to combustible materials (mm)
From the right-hand side	200
From the left-hand side	200
From the rear	200
From the front	950

SARRIA SAKAN 20

	Distance to combustible materials (mm)
From the right-hand side	400
From the left-hand side	400
From the rear	400
From the front	1100

Bear in mind that it may even be necessary to protect non-combustible material in order to prevent breakage, deformation, etc., as a result of overheating if the non-combustible material is not designed to withstand high temperatures.

2.3.3. Checks before lighting for the first time

- Make sure that the glass is not broken or damaged.
- Make sure that the flueway is not obstructed with packing or loose parts.
- Make sure that the airtight joints on the flue circuit are in perfect condition.
- Make sure that the doors close properly.
- Make sure that all moving parts are fitted in place.
- Check that the deflectors are fitted properly.

2.3.4. Height adjustment and levelling the appliance

The appliance must be perfectly level, horizontally and vertically, both at the front and on the sides (use a spirit level).

2.3.5. Casing

Make sure that the material around the appliance is not flammable or likely to deteriorate as a result of heat (wallpaper,

carpet, plastic-based casing, Silestone, etc.).

The image below gives an example of how the appliance can be encased properly:

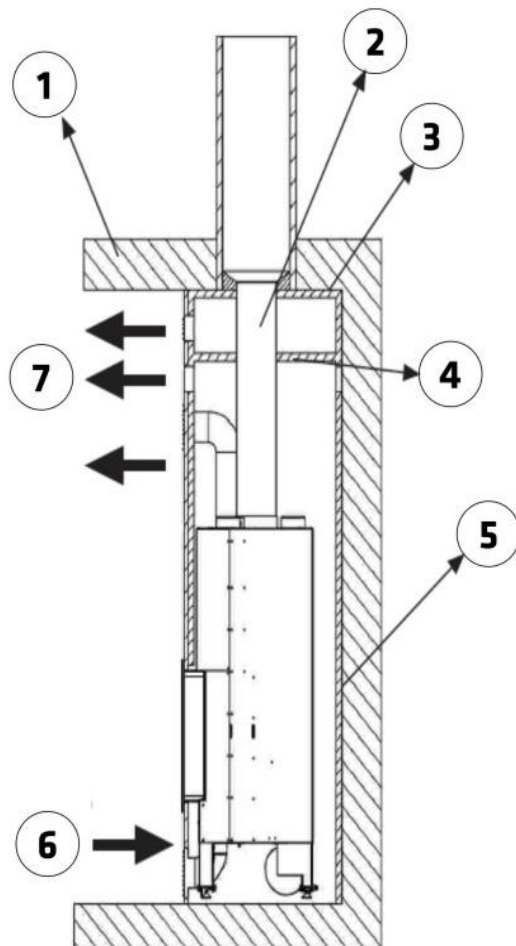

Figure No.5 - Interior diagram of the casing

Key to casing diagram:

- 1 Ceiling
- 2 Flue
- 3 Incombustible material (Inner hood insulation)
- 4 Insulating deflector made of incombustible material
- 5 Wall
- 6 Fresh-air inlet (1,000 cm²)
- 7 Hot-air outlet (1,000 cm²)

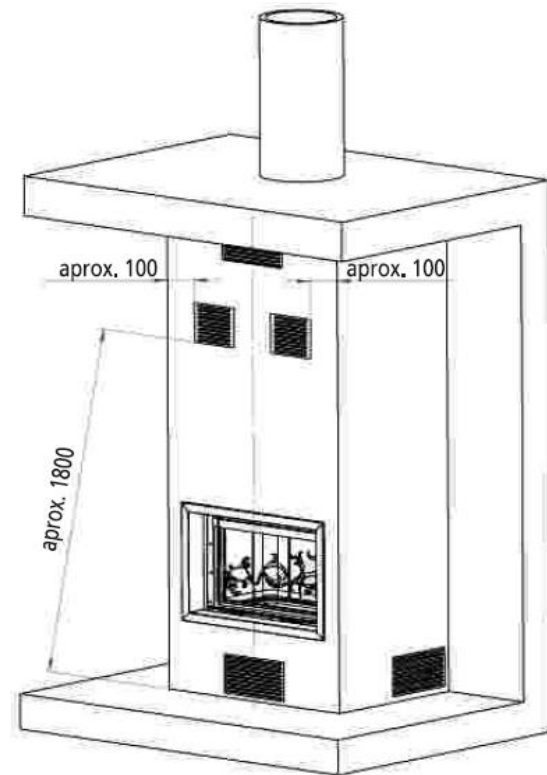

Figure No.6 - Exterior diagram of the casing

In order to enable suitable air circulation and correct operation, the casing must have a fresh-air inlet with a minimum section of 1,000cm² beneath the level of the actual appliance and a hot-air outlet measuring at least 1,000cm² above it (just before the insulating deflector inside the casing). These inlet and outlet sections must ensure air renewal in such a way as to avoid damage to parts inside the hood due to excess temperature.

This specification must be observed regardless of the type of installation chosen (with or without forced ventilation, combustion air from indoors or outdoors, directed hot-air outlets with or without pipes, etc.). A further hot-air ventilation grille is also recommended between the insulating deflector on the hood and the ceiling.

The installer must fit the necessary inspection accesses (trap doors, hatches, etc.) so that everything inside the hood that may need maintenance work, cleaning

or replacement can be accessed at any time, e.g. counterweight system, hydraulic components, heating circuit safety components.

2.3.6. Connection to the flue

The appliance must be connected to the chimney flue using special piping designed to resist the products of combustion (e.g. stainless steel, enamelled steel, etc.).

To connect the flue to the socket flange, insert the piping inside the flange and seal the joint with fire sealant or fire cement to make it completely airtight.

The installer must ensure that the pipe connected to the appliance is well secured and there is no chance of it coming free from its housing (e.g. as a result of dilatation due to temperature, etc.).

On this appliance, the flue socket can be fitted on top of the appliance.

2.3.7. Plus Option (Sarria Sakan 12-16)

The firebox is lined with refractory bricks.

Warning! Be particularly careful when loading logs in the firebox because the refractory bricks may crack or break if struck. Lacunza accepts no liability for damage caused to the refractory bricks inside the firebox as a result of incorrect loading.

High temperatures are needed in the firebox in order to keep the refractory bricks clean. Otherwise, they will blacken with use.

2.4. Chimney flue

The chimney flue must comply with present standards on the installation of chimneys.

In rooms equipped with Controlled Mechanical Ventilation, the ventilation

outlet must never be connected to the flue.

The appliance must always have its own chimney flue, never sharing a chimney flue with another appliance.

2.4.1. Type of flue

The flue must be made of special material designed to resist the products of combustion (e.g. stainless steel, enamelled steel, etc.).

Central-heating appliances (with back boiler) require a double-sleeve flue, insulated throughout the installation, even inside the building. This prevents the gases from cooling down too much and, consequently, prevents downdraughts, condensation and low top surface and oven temperatures on kitchen stoves.

If the chimney is constructed, then it is necessary to pipe and insulate it to ensure correct updraught.

The diameter of the pipe must be the same as the diameter of the flue socket on the appliance over its entire length in order to ensure correct operation.

The flue must prevent the entry of rainwater.

The flue must be clean and airtight over its entire length.

The flue must be at least 6m tall and the chimney cap must not hinder the free release of gases.

If the flue tends to suffer from downdraught, then it is necessary to fit an effective anti-downdraught cowl, a static cowl or a smoke extraction fan, or reshape the chimney.

Never make 90° bends, due to the great loss of draught they cause, and reduce 45° bends down to an absolute minimum. Each 45° bend is equivalent to a 0.5m reduction in flue length. Horizontal flue sections should not be installed because they cut updraught a great deal.

The appliance is designed to operate under controlled draught conditions. The appliance must operate at a chimney draught of between 12Pa and 15Pa. To ensure this draught, an automatic draught moderator must be installed in the flue. Uncontrolled draught operation can lead to quick damage of the appliance, which will not be covered by the warranty.

The flue must not rest its weight on the appliance, as this could damage the worktop.

Bear in mind that high temperatures may be reached in the flue, meaning that it is essential that insulation be enhanced in sections in which combustible material is present (wooden beams, furniture, etc.). It may even be necessary to protect non-combustible material in order to prevent breakage, deformation, etc., as a result of overheating if the material is not designed to withstand high temperatures.

It must be possible to clean the entire flue, no sections being left inaccessible for cleaning purposes.

2.4.2. Chimney crown

The upper end of the chimney must clear the roof, the roof ridge or any obstacle located on the roof by at least 1m.

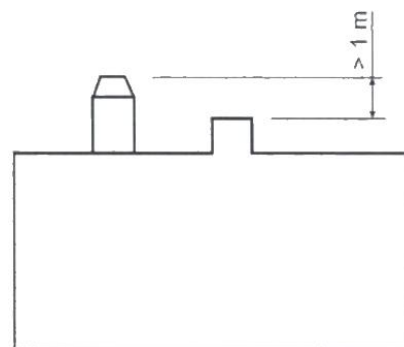
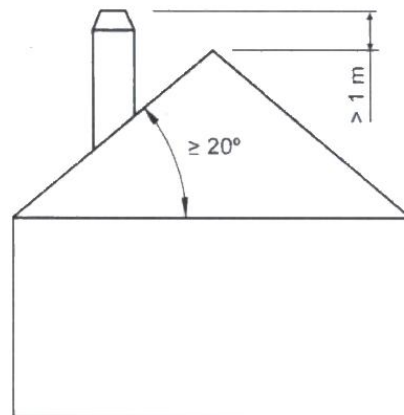
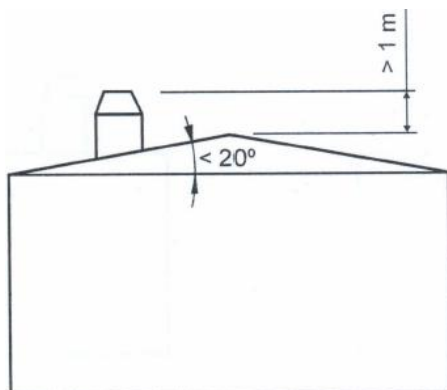

Figure No.7 - Distances between chimney crown and roof ridge

The chimney crown must clear the highest point of any neighbouring building or obstacle located within a 10m radius of the chimney outlet by more than 1m.

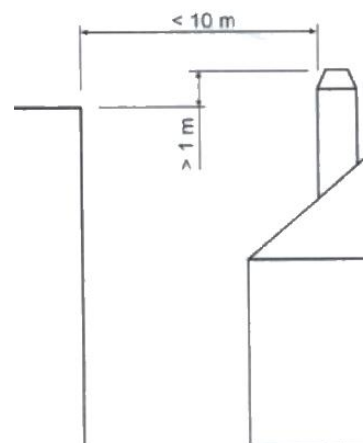

Figure No.8 - Distances between the chimney crown and objects within a 10m radius

The chimney crown must clear any neighbouring building or obstacle located

within a radius of 10m to 20m from the chimney outlet.

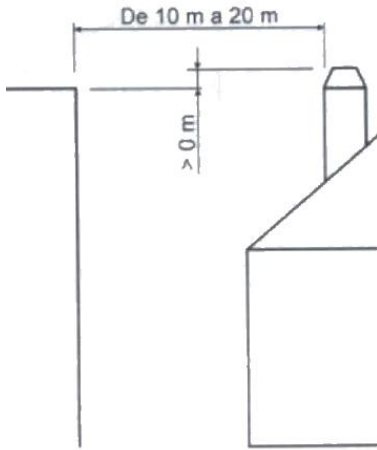

Figure No.9 - Distances between the chimney crown and objects within a radius of between 10 and 20m

2.5. Water system

IMPORTANT!

Lacunza Kalor Group accepts no liability for damage arising from incorrect connection or connections made by unqualified persons. The connection of the appliance to the heating circuit and the installation of the system must only be performed by professionals duly qualified to do so.

The water system must be connected, and the boiler checked for perfect watertightness, including with the fire lit, before encasing central-heating fireplaces. The water system must be fitted with suitable safety components to prevent potential accidents when a central-heating fireplace is in use. If the installation instructions are not observed, the product warranty is rendered null and Lacunza Kalor Group is excluded from all liability regarding personal injury or damage.

In view of the above, Lacunza Kalor Group accepts no liability for any possible breakage of the casing if the previous obligatory operation checks have not been performed.

2.5.1. Obligatory parts

All water systems involving a Lacunza central-heating appliance must have:

2.5.1.1. Expansion tank

The expansion tank may be open or closed. In either case, the expansion tank must be capable of accommodating the increase in water volume caused by heating. Lacunza recommends systems with closed expansion tanks because then the central-heating fluid does not come into contact with the atmosphere and oxidation problems are greatly reduced.

2.5.1.2. Temperature relief valve

Regardless of the expansion tank employed, the system must include a temperature relief valve set to 97°C. The probe that works the valve must be fitted at the hottest point on the system, i.e. at the point where the hot water leaves the heating appliance. Follow the indications provided in the valve manual. This valve has been individually tested by the manufacturer, who guarantees its water-tightness on fitting. If, once activated, it leaks water, this is due to excess water temperature which has deformed the seal or impurities which have embedded themselves in it. These eventualities are not covered by the warranty on the valve

2.5.1.3. Pressure relief valve

When closed expansion tanks are employed, a pressure relief valve set to 3 bar must be fitted to prevent the pressure from exceeding this mark. Follow the indications provided in the valve manual.

2.5.1.4. Automatic fill system

The automatic fill system must be set to 1.2 bar when closed expansion tanks are in use and operate using a ballcock/float mechanism that releases water from the mains supply when the water level falls

beneath the relevant height if an open expansion tank is chosen.

The automatic fill system must be fitted in such a way that it can be triggered at any point in time and can never be closed manually.

2.5.1.5. Circulation pump

A circulation pump must be fitted to make the water flow through the entire water system. We recommend that it be installed on the back-boiler return.

2.5.1.6. Pump on/off thermostat

The circulation pump must be operated by a thermostat that turns the pump on when the water in the central-heating appliance reaches 50°C and turns it off when it falls beneath this temperature. The thermostat must be fitted at the point at which the hot water leaves the appliance.

2.5.1.7. Anti-condensation system

The heating circuit must include an anti-condensation system that ensures that the return water re-enters the central-heating appliance at a temperature above 55°C.

2.5.1.8. Automatic purge valves

As many purge valves as necessary should be fitted at the highest points of the system and areas in which air is likely to accumulate.

2.5.1.9. Circuit drain valve

The system must have a valve with which to drain the circuit at its lowest point.

2.5.1.10. Excess heat discharge

The circuit must have a means by which to discharge excess heat from the back boiler, such as a heat leak radiator, a heat discharge valve, etc.

2.5.1.11. Safety coil

A heat safety device offered as an option on a large part of the Lacunza central-heating appliance range. The arrow on the heat discharge valve that comes included must point towards the appliance and be connected to either of the two male couplings on the coil. The mains water supply is connected directly to this safety valve provided mains pressure is less than or equal to 5bar; if it is higher, then a pressure regulator must be fitted to reduce the pressure to 5bar. The other male coupling on the coil must be connected to the drainage outlet with metal piping. The probe that controls the opening of the heat safety valve must be housed in the bushing nearest to the hot-water output on the appliance. A filter must be fitted prior to the heat discharge valve to prevent impurities from not allowing the valve to close properly.

Lacunza recommends the installation of safety coils on all central-heating appliances that cater for the possibility. Some of their advantages include:

- New water is not released into the water system when coils are activated, meaning that impurities-limescale cannot enter either.
- The overheated water in the back boiler is cooled down by means of the “bain-marie” system.
- The water system cannot be left empty as a result of discharge failure.
- Located at the most efficient position guaranteed (coil+discharge valve).

The manufacturer's instructions must be followed for each of the parts described above.

We recommend that a filter be installed at the mains water input to prevent impurities and foreign bodies from entering the water circuit.

Several connection kits for Lacunza central-heating appliances, which include most of these parts, can be purchased from the Lacunza catalogue to make it easier to install and maintain your appliance.

2.5.2. Relationship between the output of the central-heating appliance and radiator output

It is of the utmost importance that the nominal heat output to water generated by the appliance is proportional to the heat output of the radiators that the appliance runs. Otherwise, one of two things may occur:

The nominal output of the appliance is much higher than the output of the radiators

The entire water system can be heated using less fuel than the nominal load, but the minimum required flue temperature will not be reached, possibly leading to downdraughts, condensation. If, on the other hand, the appliance is fuelled using the nominal load, the system will be unable to accommodate all the output generated, causing safety valves to trip.

The nominal output of the appliance is much lower than the output of the radiators.

The appliance is always forced to work at the upper end of its capacity and is never able to heat the system, leading to low appliance temperature and poor combustion, bringing subsequent smoke and condensation problems.

By way of example, one standard 60cm-wide radiator column/unit has a heat output capacity $\Delta T_{50^{\circ}\text{C}}$ of 143W/unit, meaning that a system involving 100 x 60cm-wide units has a total output of 14.3 kW.

In the example above, possible heat loss resulting from poor insulation of circuit-water pipes is not taken into

account, it being supposed that said pipes are properly insulated. If your system does not have insulated pipes, then this factor should be taken into account in the calculation.

2.5.3. KIT COMBI and BASIC. Combined central-heating appliance + gas/heating-oil boiler installation

There is a Lacunza system available for Lacunza central-heating appliances to be installed as part of water systems in combination with gas/heating-oil boilers which includes most of the parts needed in order to make the connection and automate and run the two systems independently.

2.5.4. Checking the watertightness of the system

The watertightness of the back boiler has been tested in the factory at a pressure of 3.5 bar. Never connect the appliance to the circuit to test the watertightness of the water system and if you do connect it, never perform tests at pressures of more than 3 bar. Lacunza cannot be held liable for the consequences of doing so.

Use the appliance for 15 days before encasing it to ensure there are no leaks on the heating appliance connections.

2.5.5. Connecting the back boiler to the central-heating circuit

Working water pressure: 1.2 bar.

Cold water must always enter the appliance (return) at the bottom and hot water must always leave the appliance to feed the heating circuit (output) at the top.

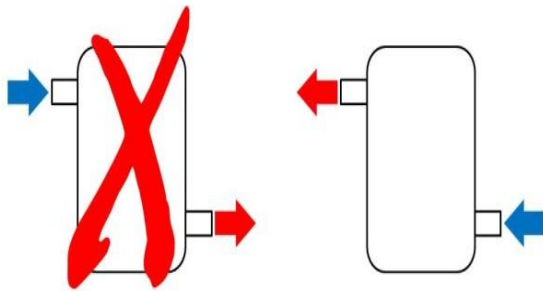

Figure No.10 - Wrong connection (left) and Right connection (right)

If the appliance offers the possibility to make connections on both sides, these connections must always be diagonal, otherwise the heat output transmitted to the water will be reduced.

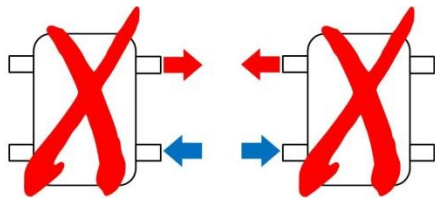

Figure No.11 - Incorrect connections (lower thermal output to water).

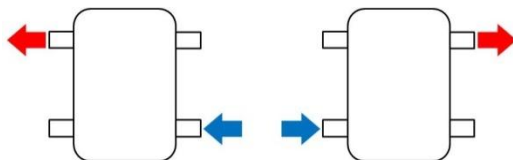

Figure No.12 - Correct connections

In addition to the flow and return connection fittings on the coil, the appliance has a further 5 connection fittings on the coil.

- Connection (1): 1/2" female fitting for the thermostatic and thermal discharge safety valve probe that Lacunza supplies as an accessory.
- Connection (2): 1/2" female fitting for the thermostatic immersion probe sheath supplied by Lacunza in the KIT COMBI and BASIC accessories. This probe will control the start-stop of the circulator pump in the heating circuit.

- Connection (3): 3/8" female fitting for the automatic air vent. Not supplied with the appliance.

• Connection: If the appliance is fitted with the safety coil inside the coil, there will be 2 1/2" male fittings. The thermal relief valve supplied by Lacunza (see the valve instruction manual) will be connected to one of them, the outlet (4), with the arrow pointing towards the inside of the appliance, so that the coil will be without water while the valve is not operating. To make this connection it will be necessary to insert an adaptor, as the thermal discharge valve has 3/4" female outlets. The other end of the valve, at its inlet, will be connected to the mains water.

- Connection (5): Return of the safety coil circuit to be connected to the drain. Male 1/2" fitting.

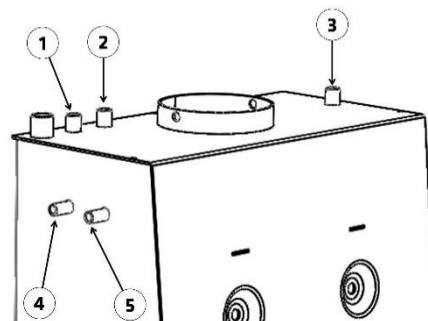
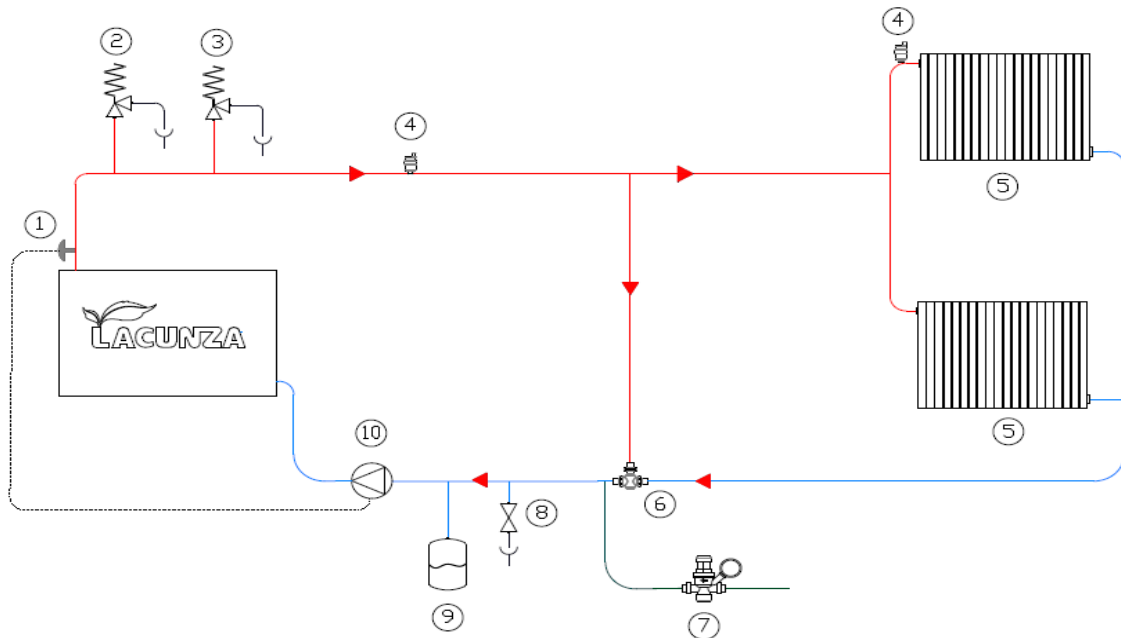

Figure No.13 - Connecting fittings

2.5.6. Electrolytic corrosion

We recommend that electrolytic connectors be fitted at the point where the piping connects to the back boiler on all water systems involving non-steel, metal piping.

2.5.7. Guideline water system diagrams
Diagram 1

When the water in the back boiler reaches 50°C, the thermostat (1) trips the circulation pump (10) on until the temperature of the water falls beneath 50°C.

Until the temperature of the water returning from the radiators (5) exceeds 55°C, the anti-condensation valve (6) mixes water leaving the back boiler with water returning from the radiators so that its temperature exceeds 55°C, thereby minimising condensation problems arising as a result of the water system. When the temperature of the water returning from the radiators passes 55°C, the anti-condensation valve opens all the hot-water flow to the radiators.

In the event of overheating or excess pressure, the safety systems (the 97°C heat discharge safety valve (2), 3-bar pressure safety valve (3) and the automatic fill system (7)) come into action to render the system safe.

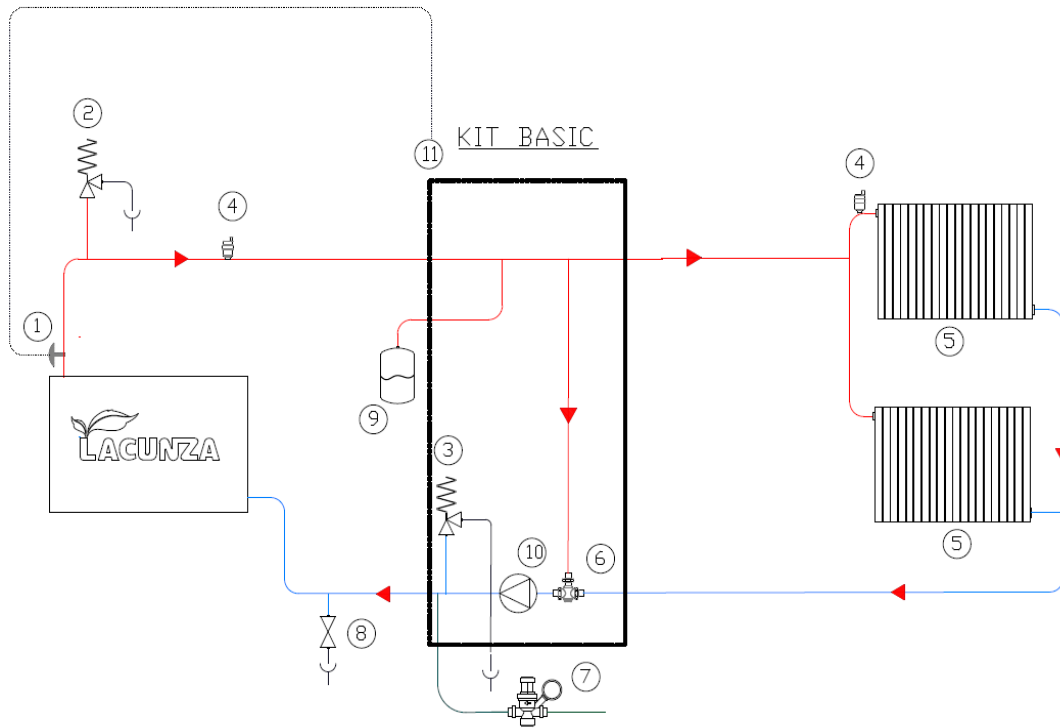
Diagram 2

When the water in the back boiler reaches 45°C, the thermostat (1) sends a signal to the automatic regulator (11) and the regulator activates the circulation pump (11) until the temperature of the water falls beneath 43°C.

Until the temperature of the water returning from the radiators (5) exceeds 55°C, the anti-condensation valve (6) mixes water leaving the back boiler with water returning from the radiators so that its temperature exceeds 55°C, thereby minimising condensation problems arising as a result of the water system. When the temperature of the water returning from the radiators passes 55°C, the anti-condensation valve opens all the hot-water flow to the radiators.

In the event of overheating or excess pressure, the safety systems (the 97°C heat discharge safety valve (2), 3-bar pressure safety valve (3) and the automatic fill system (7)) come into action to render the system safe.

In this case, the parts inside the rectangle come supplied in the Basic kit. The kit also has an anti-ice protection system and an anti-blockage system to protect the water system when not in use in the summer.

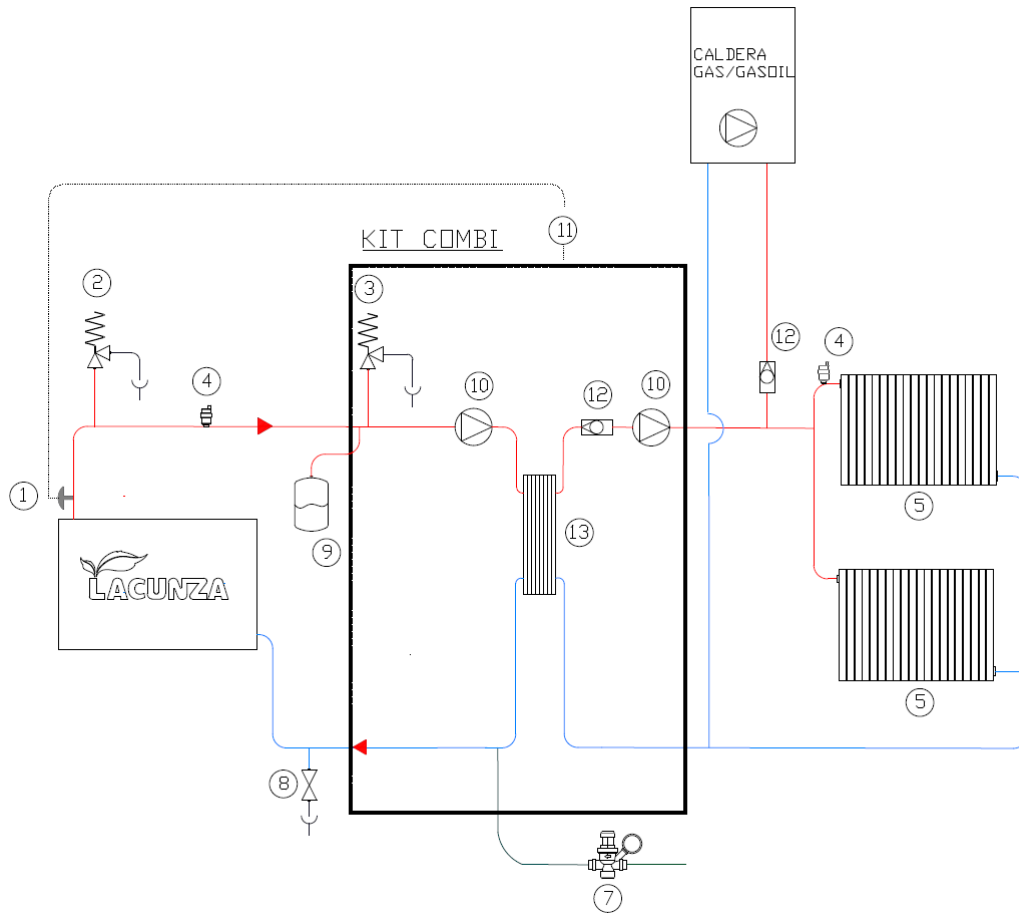
Diagram 3

When the water in the back boiler reaches 45°C, the thermostat (1) sends a signal to the automatic regulator (11), which activates the back boiler circulation pump (10), causing the water to circulate without exchanging heat with the radiator circuit via the plate heat exchanger (13) until the temperature of the water reaches 55°C, at which point the regulator activates the radiator circuit pump, causing heat to be exchanged in the plate heat exchanger and releasing hot water to the radiators.

When the temperature of the water in the back boiler drops below 53°C, the radiator pump stops, and the back boiler pump stops when the temperature falls beneath 43°C.

While the radiators are being heated by the wood-burning appliance, the Combi kit electronic regulator stops the gas/heating-oil boiler from starting up even though the thermostat says that it should in order not to waste boiler fuel. When the water from the wood-burning central-heating appliance drops beneath 48°C, the automatic regulator lets the gas/heating-oil boiler heat the radiators again.

In the event of overheating or excess pressure, the safety systems (the 97°C heat discharge safety valve (2), 3-bar pressure safety valve (3) and the automatic fill system (7)) come into action to render the system safe.

In this case, the parts inside the rectangle come supplied in the Combi kit. The kit also has an anti-ice protection system and an anti-blockage system to protect the water system when not in use in the summer.

Key to water system diagrams:

- 1 50°C pump start thermostat
- 2 97°C heat discharge safety valve
- 3 3-bar pressure discharge safety valve
- 4 Automatic purge valve
- 5 Radiators / heat emitters
- 6 55°C anti-condensation valve
- 7 Automatic fill system
- 8 Drainage outlet
- 9 Closed expansion tank
- 10 Circulation pump
- 11 Automatic regulator
- 12 One-way valve
- 13 Plate heat exchanger

*Note: the heat discharge valve is capable of withstanding a maximum fluid temperature of 110°C.

3. INSTRUCTIONS OF USE

The manufacturer accepts no liability whatsoever for damage caused to parts as a result of the improper use of non-recommended fuels, modifications made to the appliance or how it is installed.
Only use original replacement parts.

All local and national regulations, including those referring to national and European standards, must be observed when using the appliance.

Heat is diffused by radiation and convection via the front and exterior of the appliance.

In the case of central-heating appliances (with back boiler), a large proportion of the heat generated is also diffused by conduction from the appliance to the radiant fluid, i.e. the heating-circuit water.

3.1. Fuel

This appliance must not be used as an incinerator. Do not use non-recommended fuels.

- Use dry logs (max. 16% humidity), cut at least 2 years ago, clean of resin and stored in a sheltered, ventilated place.
- Use hard woods with high calorie values and good ember production.
- Large logs should be cut to useable lengths before being stored. The logs should have a maximum diameter of 150mm.
- Finely-chopped wood produces greater heat output, but also burns more quickly.

Optimum fuels:

- Beech.

Other fuels:

- Oak, chestnut, ash, maple, birch, elm, etc.

- Pine and eucalyptus logs are low density and produce very long flames, and may cause the parts of the appliance to wear out more quickly than normal.

- Resinous wood may mean that the appliance and the flue need to be cleaned more often.

Non-permitted fuels:

- All types of coal and liquid fuel.
- “Green wood”. Green or damp wood reduces the performance of the appliance and leads to soot and tar build-up on the inner walls of the flue, obstructing it.

- “Recovered wood”. The burning of treated woods (railway sleepers, telegraph posts, plywood, fibreboard, pallets, etc.) quickly blocks the system (soot and tar build-up), harms the environment (pollution, smells) and may lead to deformation of the firebox due to overheating.

- All materials which are not wood (plastic, spray cans, etc.).

- Never use gasoline, gasoline-type lamp fuel, paraffin, charcoal lighter fluid, ethyl alcohol or similar liquids to ignite or rekindle a fire in the equipment. Keep all such liquids away from the equipment while it is in use.

Green and reprocessed wood may cause chimney fires.

The graph below shows how the humidity of firewood affects its heat output:

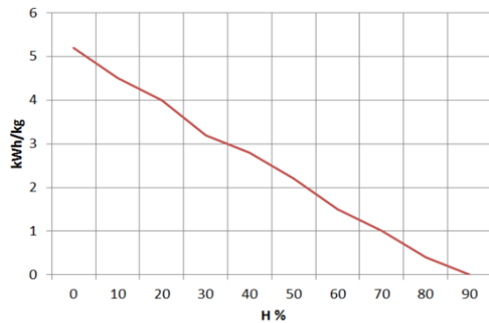

Figure No.14 - Relationship between firewood humidity and heat output.

3.2. Description of the parts of the appliance

3.2.1. Operating components

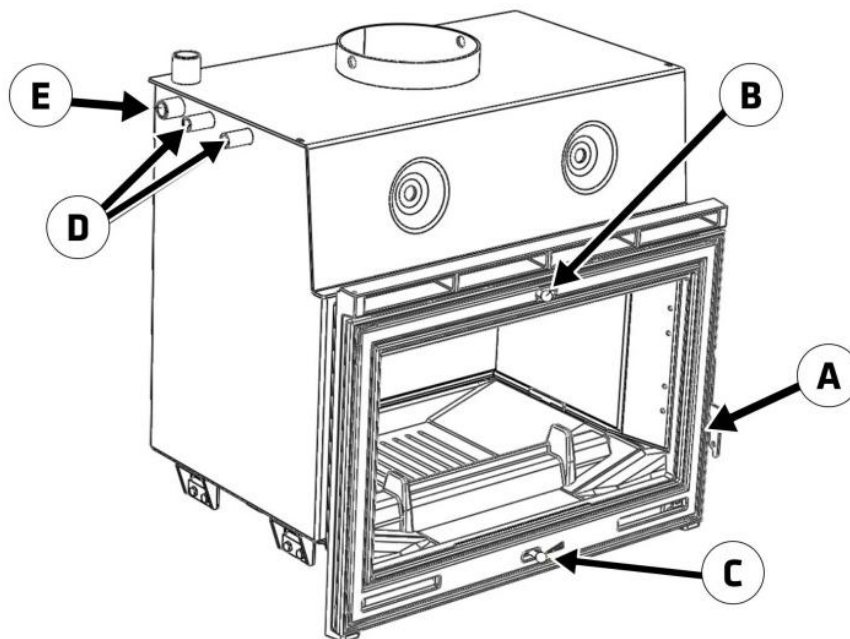

Figure No.15 - Operating components on the appliance

- A: Firebox door handle
- B: Secondary air intake
 - B1 open (right)
 - B2 closed (left)
- C: Primary air intake
 - C1 open (right)
 - C2 closed (left)
- D: Safety coil
- E: Safety coil probe.

3.3. Lighting

Use of the appliance in warm weather (warm days, early hours of the afternoon on sunny days) may lead to lighting and updraught problems.

Certain weather conditions, such as fog, ice, humidity entering the flue, etc., may hinder sufficient updraught in the flue and lead to suffocation.

Proceed as follows in order to light the appliance satisfactorily:

- Open the firebox door and open all the firebox air-intake inlets to the full.
- Place paper or a firelighter and some wood chips in the firebox.
- Light the paper or firelighter.
- Leave the door slightly ajar, the width of two or three fingers, for about 15 minutes until the glass warms up.
- The first time the appliance is lit, the fire should be gentle to allow the parts of the appliance to dilate and dry.

Important: The first time it is lit up, the appliance may give off smoke and strange smells. This is not a cause for concern. Open an outdoor window to ventilate the room during the first few hours of operation.

If you notice water around the appliance, this is produced by the condensation of the moisture in the wood on lighting the fire. This condensation will no longer appear when the appliance has been lit three or four times and has adapted to its flue. If it does not disappear, then check the flue draught (length and diameter of the flue, flue insulation, airtightness) and the humidity of the wood used.

3.4. Loading fuel

In order to load firewood, open the firebox door gently, preventing the sudden

entry of air to the firebox so that smoke does not enter the room that the appliance is installed in.

Perform this operation with the glove to prevent burns to the hands.

The maximum height of the load shall be approximately one third of the height of the firebox.

The minimum interval between loads for nominal heat output is 60 minutes.

Always load with the nominal amount (see table in section 1.1).

For minimum burning (e.g. at night), use thicker logs.

When the firebox is loaded, close the door.

3.5. Operation

The appliance should be operated with the door closed.

For safety reasons, never close all the appliance's combustion-air intakes.

Primary-air intake

By opening this inlet, air enters the firebox via the firebox grille.

Secondary-air intake

By opening this inlet, air enters the firebox via the top of the firebox door.

IMPORTANT: Keeping the secondary-air intake open helps keep the door glass cleaner for longer.

In class B or BE appliances (without combustion air ducting from the street), when the appliance is not in use, the appliance-flue duct assembly may represent a heat leakage route to the street. When the appliance is not in use, it is advisable to leave the air inlet registers to the combustion chamber closed to minimise these energy losses.

3.6. Removing ash

Following sustained use of the appliance, it is necessary to remove the ash from the firebox. Remove the ashpit box when cold or using something to prevent yourself from getting burned (glove).

Never throw hot embers into the rubbish.

Access the ashpit by opening the door on the appliance.

3.7. Deflectors.

The appliance has 1 (2) deflector/s.

Dismantling the Sarria-Sakan Plus deflector

First remove the lower deflector; lift one side of the deflector until it clears the support on the other side, allow it to drop and extract by pulling towards the front.

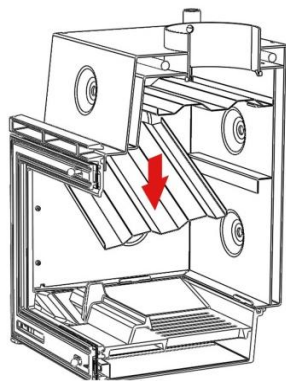
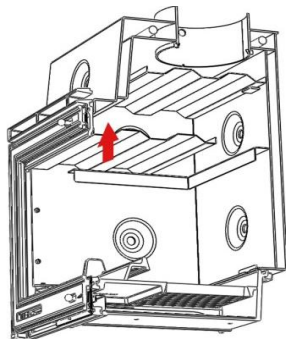

Figure No.16 - Dismantling the lower Sarria-Sakan Plus deflector

Then remove the second deflector by drawing it forwards and allowing it to drop at the rear.

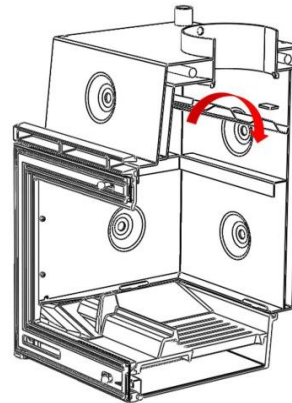
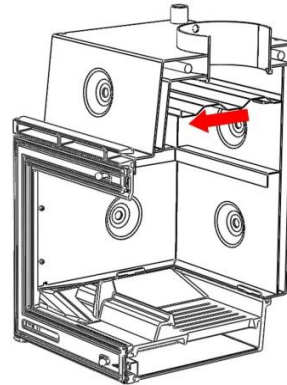

Figure No.17 - Dismantling the upper Sarria-Sakan Plus deflector

Soot falling from the flue may build up on the deflector.

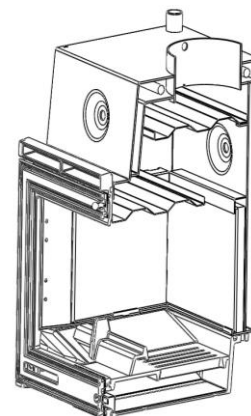

Figure No.18 - Section view with two deflectors fitted (Sarria-Sakan Plus)

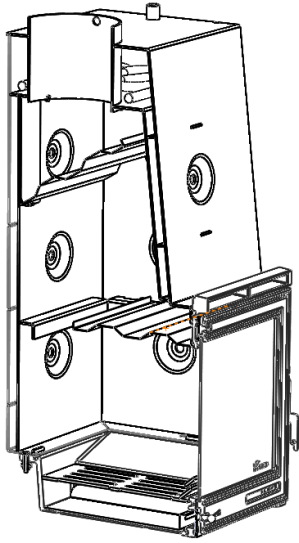

Figure No.19 - Section view with two deflectors fitted (Sarria-Sakan 20)

4. MAINTENANCE AND IMPORTANT ADVICE

4.1. Maintenance of the appliance

The appliance, the flue connector piping and the flue must be cleaned regularly, particularly following long periods without use.

4.1.1. Firebox

Clean the firebox area of ash, etc.

On central-heating appliances, clean the walls of soot (creosote) in order to enhance performance.

4.1.2. Inside the appliance

Clean the firebox area of ash. Clean the deflectors, where soot may build up.

Clean-scrape the soot (creosote) from the walls of the back boiler to enhance its performance.

4.1.3. Painted sheet-steel-cast-iron parts.

These parts should be cleaned with a brush or dry cloth. Do not dampen the parts: the steel could rust and the paint could blister and chip. Be particularly careful when cleaning the glass: the liquids used must not dampen the painted steel.

4.1.4. Firebox glass

To keep the glass as clean as possible for as long as possible, the secondary air register should be kept open. However, over the hours of use, the glass may become dirty. To clean it, we will use specific degreasing products or dry cleaning products for this task.

The cleaning should be carried out with the glass cold and taking care not to apply the glass cleaner directly on the glass as, if it comes into contact with the door's closing cord, it may deteriorate. Put the cleaning product on the cloth.

It is also important to prevent the cleaning liquid from getting into the moving mechanism of the register, as this could jam it.

Attention, never let the product drip into the lower part of the glass. The accumulation of the cleaning product, with soot or ash residues, can damage the screen printing on the glass.

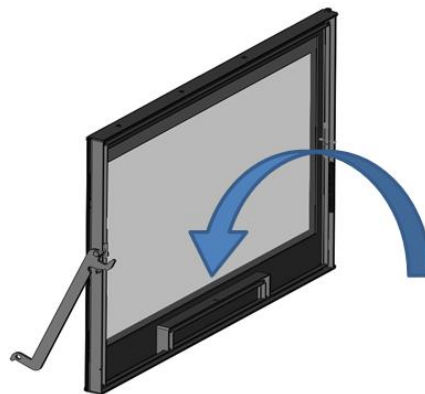

Note: If we use the appliance in draught conditions higher than 15Pa or burn more wood (per hour) than those indicated in table 1.1, we will subject the appliance to working conditions higher than those designed for it. This can lead to aggressive fouling of the glass (white halo), which cannot be cleaned by the traditional method.

Caution, the vitro ceramic glass is prepared to support 700°C. Never let burning woods or combustion flame beating against the glass for prolonged periods of time. In this case, the glass would be submit to temperatures above 750°C, this could change the internal structure of the glass and make it opaque (irreversible phenomenon).

4.2. Maintenance of the chimney flue

VERY IMPORTANT: In order to avoid incidents (chimney fires, etc.), it is necessary to perform maintenance and cleaning operations on a regular basis; if the appliance is used often, then the



chimney and the flue connector piping must be swept several times a year.

In the event of fire in the chimney, close the flue draught, close doors and windows, remove embers from the firebox, block the connection hole with damp cloths and call the fire brigade.

4.3. Important advice

Lacunza recommends that only Lacunza-authorized replacement parts be used.

Lacunza accepts no liability for any modification to the product which it has not authorized.







This appliance is a heat-producing appliance and contact may lead to burns.

This appliance may remain HOT for a period of time after it has gone out. MAKE SURE THAT SMALL CHILDREN DO NOT GO NEAR IT.

5. TROUBLESHOOTING



This symbol means that a qualified professional should be called to perform the operation.

Problem	Probable causes		Solution
The fire does not light properly The fire does not stay alight	Green or damp wood		Use hard woods, cut at least 2 years ago and stored in a sheltered, ventilated place
	The logs are too large		Use crumpled paper or firelighters and dry wood chips to light the fire. Use split logs to keep the fire going
	Poor-quality wood		Use hard woods which produce heat and embers (chestnut, ash, maple, birch, elm, beech, etc.)
	Insufficient primary air		Open the primary- and secondary-air intakes completely, or even open the door slightly. Open the outdoor-air inlet grille
	Insufficient updraught		Check that the draught is not blocked. De-soot if necessary. Check that the flue is in perfect condition (airtight, insulated, dry, etc.)
The fire flames up too much	Excessive primary air		Close the primary- and secondary-air intakes partially or totally
	Excessive updraught		Install a draught damper
Smoke given off on lighting	Poor-quality wood		Do not continually burn chips, carpentry scraps (plywood, pallets, etc.)
	Cold flue		Heat up the flue by burning a piece of paper in the firebox.
Smoke during burning	The room is at low pressure		In rooms with Controlled Mechanical Ventilation, leave an outdoor window ajar until the fire is fully alight.
	Too little wood loaded		Load as recommended. Loads notably smaller than those recommended lead to low smoke temperature and downdraught.
	Insufficient updraught		Check the condition of the flue and insulation. Check that the piping is not blocked. Clean mechanically if necessary
	Wind enters the flue		Install an anti-downdraught system (Cowl) at the top of the chimney
Does not warm up enough	The room is at low pressure		In rooms with Controlled Mechanical Ventilation, there must be an outdoor-air inlet
	Poor-quality wood		Only use the recommended fuel
Safety valves do not close 100%	Impurities in seal joint		Run cold water through the valve several times to clean it of impurities. Fit filters to prevent impurities from entering.
	Deformation of seal joint		Fit a new valve
Water condenses (after the appliance has been lit more than 3 or 4 times)	Too little wood loaded		Load as recommended. Loads notably smaller than those recommended lead to low smoke temperature and condensation.
	Green or damp wood		Use hard woods, cut at least 2 years ago and stored in a sheltered, ventilated place.
	Condition of the flue		Lengthen the flue (5-6 metres minimum). Insulate the flue properly. Check the airtightness of the flue/appliance.
	Water circuit		Failure or lack of mixing valve anti-condensation system. Output of the water system not in proportion to the heating appliance. The circulation pump must be activated when the water temperature is over 55°C

6. BASIC BREAKDOWNS

SARRIA (TODAS SUS VERSIONES)

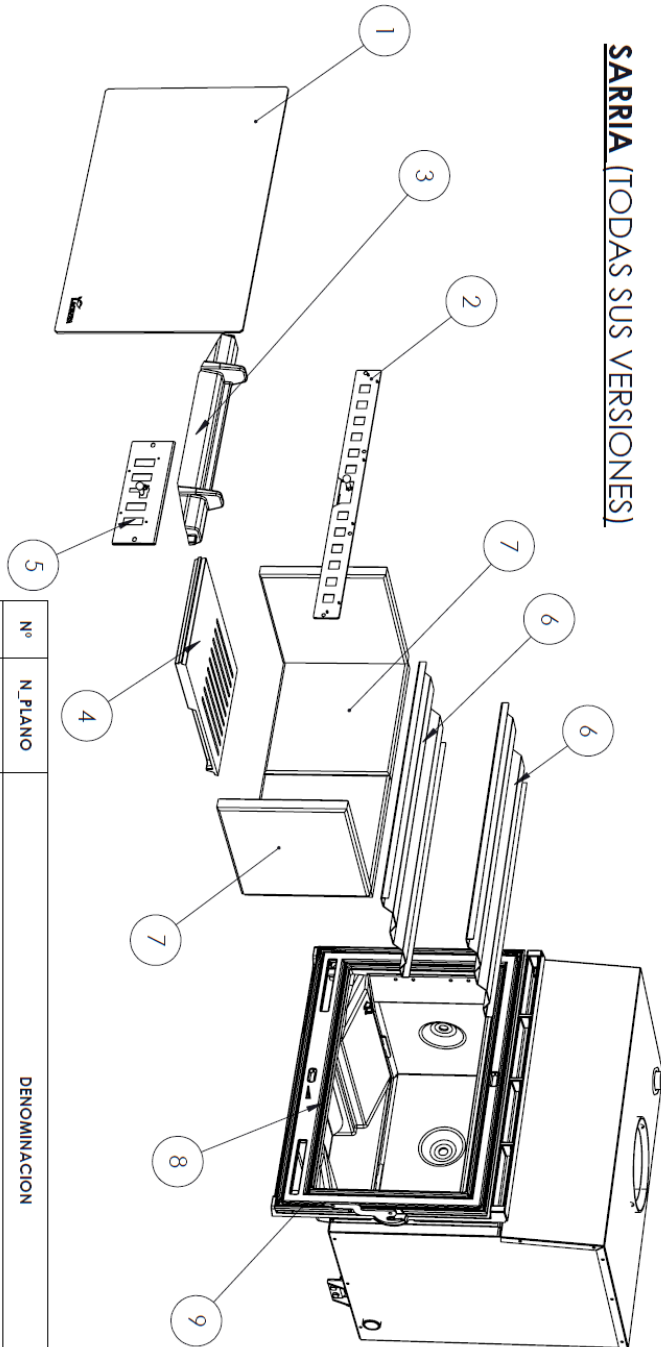

Nº	N. PLANO	DENOMINACION	CANT.
1	500000000116	Cristal SARRIA-IN700-RE700	1
2	5030000000004	Registro secundario Sarria-IN700	1
3	500000000115	Separador IN-700	1
4	500000000113	Partilla IN-700	1
5	5030000000005	Registro primario SARRIA-IN700	1
6	503160000001	DEFLECTOR SARRIA 1UD (2UDS DE DEFLECTOR PARA SARRIA PLUS)	2
7	5030000000006	SARRIA REFRACTARIO PLUS (SOLO SARRIA PLUS)	4
8	500900000010	CORDON CERAMICO DIAM. 8 NEGRO	3
9	500000000212	CORDON FIBRA DE VIDRIO PLANO DE 8X1 NEGRO	3

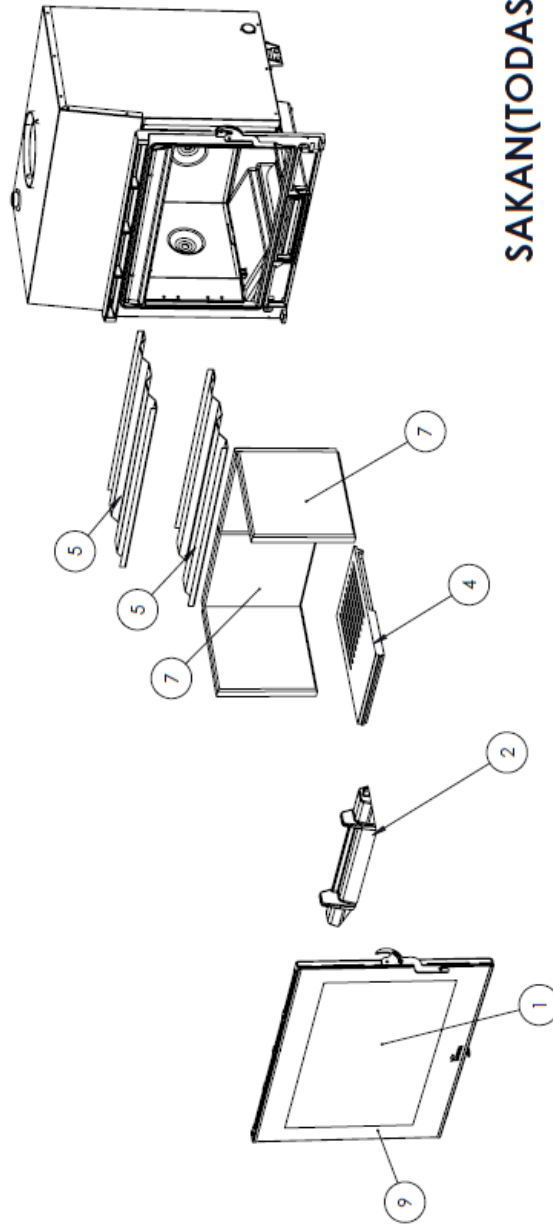
SAKAN(TODAS SUS VERSIONES)

Nº	N. PLANO	DENOMINACION	CANTIDAD
1	504000000862	CRISTAL SAKAN-NEPAL-INDIA	1
3	500000000115	Separador IN-700	1
4	500000000113	Panel IN-700	1
5	502160000001	Deflector Samia Lud (2uds. deflector para Samia Plus)	1
6	502160000001	Solape ladrillos delantero Samia	2
7	503000000006	SARRIA REFRACTARIO PLUS(SOLO OPCION PLUS)	4
8	509000000010	CORDON CERAMICO DIAM.8 NEGRO	1
9	500000000212	CORDON FIBRA DE VIDRIO PLANO 8X1 NEGRO	3

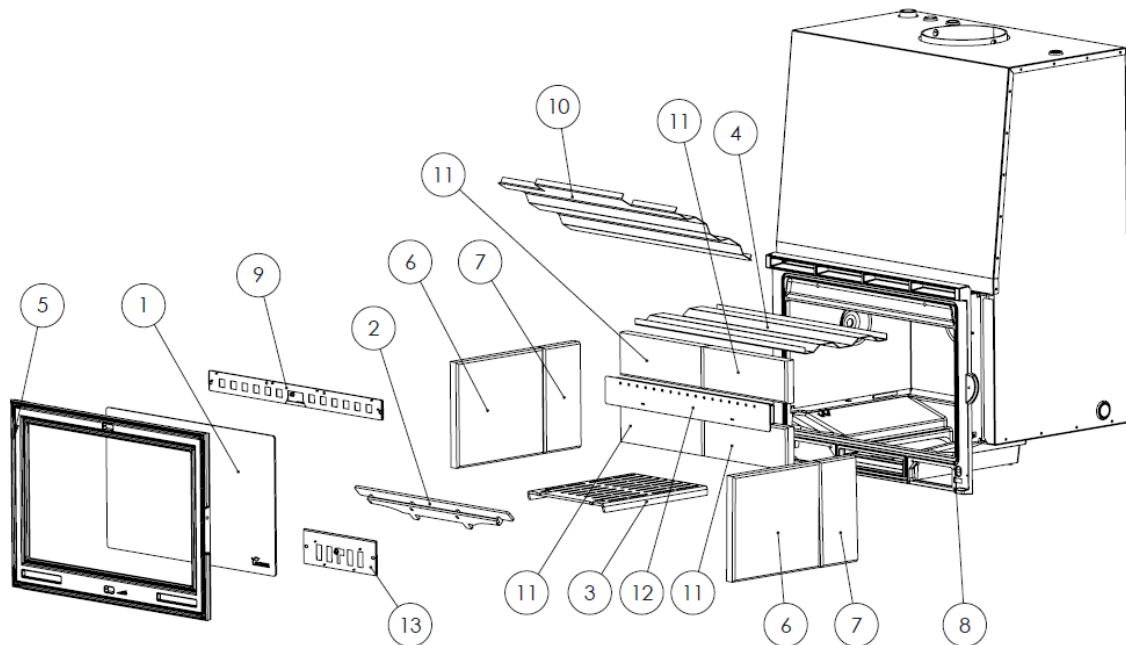
SARRIA 20

Nº	CÓDIGO	DENOMINACION	CANTIDAD
1	500000000116	CRISTAL SARRIA-IN700-RE-700	1
2	503450000000	SEPARADOR SARRIA SAKAN 20	1
3	503450000001	PARRILLA SARRIA SAKAN 20	1
4	503450000002	DEFLECTOR SARRIA SAKAN 20	1
5	500000000212	CORDON FIBRA DE VIDRIO PLANO 8X1 NEGRO	3
6	503000000006	SARRIA/SAKAN REFRACTARIO PLUS LATERAL ANCHO	2
7	503450000003	SARRIA/SAKAN 20 REFRACTARIO PLUS LATERAL ESTRECHO	2
8	500900000010	CORDON CERAMICO DIAM.8 NEGRO (m)	3
9	503000000004	REGISTRO SECUNDARIO SARRIA IN700	1
10	503450000007	Sarria-Sakan 20 eco, Deflector Superior	1
11	503450000009	Sarria-Sakan 20/Sara-Enara Refract Plus TRASERO	4
12	503450000008	Sarria-Sakan 20 eco, Tubo D/Combustion	1
13	503000000005	REGISTRO PRIMARIO SARRIA IN-700	1

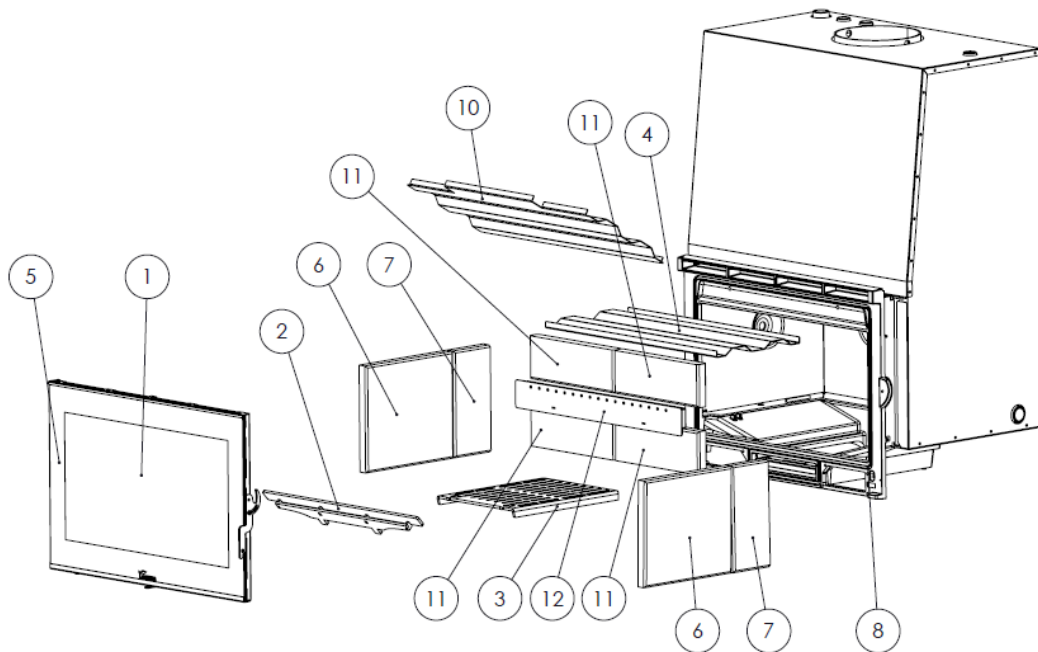
SAKAN 20

Nº	CÓDIGO	DENOMINACION	CANTIDAD
1	504000000862	CRISTAL SAKAN NEPAL INDIA	1
2	503450000000	SEPARADOR SARRIA SAKAN 20	1
3	503450000001	PARRILLA SARRIA SAKAN 20	1
4	503450000002	DEFLECTOR SARRIA SAKAN 20	1
5	500000000212	CORDON FIBRA DE VIDRIO PLANO 8X1 NEGRO	3
6	503000000006	SARRIA/SAKAN REFRACTARIO PLUS LATERAL ANCHO	2
7	503450000003	SARRIA/SAKAN 20 REFRACTARIO PLUS LATERAL ESTRECHO	2
8	500900000010	CORDON CERAMICO DIAM.8 NEGRO (m)	3
9	503000000004	REGISTRO SECUNDARIO SARRIA IN700	1
10	503450000007	Sarria-Sakan 20 eco, Deflector Superior	1
11	503450000009	Sarria-Sakan 20/Sara-Enara Refract Plus TRASERO	4
12	503450000008	Sarria-Sakan 20 eco, Tubo D/Combustion	1

7. PRODUCT RECYCLING

The recycling of the appliance is the exclusive responsibility of the owner, who must act in compliance with the laws in force in his country regarding safety, respect and protection of the environment. At the end of its useful life, the product must not be disposed of with urban waste.

It can be delivered to the specific selective collection centers set up by the municipalities, or to retailers who offer this service. The selective disposal of the product avoids possible negative consequences for the environment and for health and makes it possible to recover the materials of which it is composed, thus obtaining significant savings in terms of energy and resources.

It can be disassembled (the parts are assembled with screws or rivets) and the components can be deposited in their corresponding recycling channels. The components of the appliance are: steel, cast iron, glass, insulating materials, electrical material, etc.

8. DECLARATION OF PERFORMANCE



CH-C-007

DECLARACIÓN DE PRESTACIONES Conforme al R. E. Productos Construcción (UE) N° 305/2011

DÉCLARATION DE PERFORMANCE Selon le Règlement (UE) N° 305/2011

DICHIARAZIONE DI PRESTAZIONE In base al Regolamento (UE) N° 305/2011

DECLARATION OF PERFORMANCE According to Regulation (UE) N° 305/2011

DECLARAÇÃO DE PRESTAÇÕES Em base com o Regulamento (UE) N° 305/2011

- Nombre y/o código de identificación única del producto:
Nom-code d'identification unique du produit
Nome-codice identificativo unico del prodotto
Unique identifier nome-code for product
Nome-código de identificação único do produto
 - Marca, marque, marca, mark, marca: LACUNZA
 - Tipo, type, tipo, type, tipo: Chimenea calefactora, Appareil insérable, Apparecchio a incasso, Insertable appliance, Aparelho encastrável Modelo, modèle, modello, model, modelo: SARRIA12 CALEFACTORA, SARRIA12 PLUS CALEFACTORA, SAKAN12 CALEFACTORA, SAKAN12 PLUS CALEFACTORA
- Uso o usos previstos del producto: Chimenea de carga manual, para quemar combustibles sólidos (indicado en instrucciones), cuya función es calentar el espacio en el que está instalada y proporcionar también agua caliente sanitaria y/o calefacción central.
Utilisation prévue du produit: Appareil insérable qui se charge manuellement, conçu pour brûler des combustibles solides (indiqués dans le Manuel d'Instructions), dont la fonction est de chauffer l'espace où il est installé (et de fournir de l'eau chaude sanitaire et/ou le chauffage central).
Usi previsti del prodotto: Apparecchio a incasso a carico manuale, per bruciare combustibili solidi (indicati nelle istruzioni), la cui funzione è riscaldare lo spazio in cui è installato (e fornire anche acqua calda sanitaria e/o riscaldamento centrale).
Entended uses of the product: Insertable appliance to be loaded by hand and designed to burn solid fuels (indicated in instructions), whose function is to heat the space in which it is installed (and also provide hot water and/or central heating).
Utilização prevista do produto: Aparelho encastrável de carga manual, para queimar combustíveis sólidos (indicado nas instruções), cuja função é aquecer o espaço no qual está instalado (e proporcionar também água quente sanitária e/ou aquecimento central).
- Nombre y dirección del fabricante: LACUNZA KALOR GROUP S.A.L.
Nom et adresse du fabricant: Pol. Ind. Ibarrea s/n 31800 Alsasua (Navarra) (España)
Nome e indirizzo del fabbricante: Teléfono: (0034) 948563511
Name and adress of the manufacturer: Fax: (0034) 948563505
Nome e endereço do fabricante: Email: comercial@lacunza.net
- Sistema de evaluación y verificación de la constancia de las prestaciones: 3
Système d'évaluation et contrôle de la constante de performance: 3
Sistema di valutazione e verifica della costanza della prestazione: 3
Assessment and verification system for constancy of performance: 3
Sistema de avaliação e verificação da regularidade do desempenho: 3
- Organismo Notificado, Laboratoire notifié, Laboratorio notificato, Laboratory notified, Laboratório notificado: RRF N° NB1625 Rhein-Ruhr Feuerstätten
Prüfstelle GmbH Am Technologie Park 1 D-45307 ESSEN
Por el sistema, Selon le system, In base al system, Based on system, Em base ao system : 3.
Documento emitido (fecha), Numéro du rapport d'essai (date), Numero rapporto di prova (data), Test report number (date), Número relação de prova (data): 29133303 (15-07-2013)

6. Prestaciones declaradas, Performance déclarée, Prestazioni dichiarate, Services declare, Desempenhos declarados:

Especificaciones técnicas armonizadas, Spécifications techniques armonices, Specifica tecnica armonizzata, Harmonised technical specifications, Especifica técnica harmonizada EN13229:2001/A1:2002/A2:2004/AC:2006/AC:2007	
Características esenciales, Caractéristiques essentielles, Caratteristiche essenziali, Essential features, Características essenciais	Prestaciones, Performance, Prestazione, Services, Desempenho
Reacción al fuego, Résistance au feu, Resistenza al fuoco, Resistance to fire, Resistência ao fogo	Cumple, Conforme, Conforme, Compliant, Em Conformidade
Distancia mínima de seguridad a materiales combustibles, Distance minimum aux matériaux combustibles, Distanza minima da materiali combustibili, Minimum distance from combustible material, Distância mínimo de materiais combustíveis	Izquierda, gauche, sinistra, left, esquerda: 200mm Derecha, droite, diritto, right, direito: 200mm Trasera, arrière, retro, back, traseira: 200mm Delantera, avant, fronte, front, frente: 1000mm Encimera, dessus, sopra, above, acima: 750mm
Temperatura humos a potencia térmica nominal, Température des fumées, Temperatura fumi, Fume temperatura, Temperatura dos gases de combustão	284 °C
Emisión de productos de combustión, Emisión des produits de combustion, Emisión prodotti combustione, Combustión productos emisiones, Emissões de produtos de combustão	Cumple, Conforme, Conforme, Compliant, Em Conformidade
Concentración media CO al 13% O2, Concentration moyenne CO al 13% O2, CO concentrazione media di O2%, Average concentration CO to O2%, CO concentração média de O2%	0.07 %
Desprendimiento de sustancias peligrosas, Rejet de substances dangereuses, Rilascio di sostanze pericolose, Release of hazardous substances, Lançamento de substâncias perigosas	Cumple, Conforme, Conforme, Compliant, Em Conformidade
Temperatura superficial, Température de surface, Temperatura superficiale, Surface temperatura, Temperatura superficial	Cumple, Conforme, Conforme, Compliant, Em Conformidade
Seguridad eléctrica, Sécurité électrique, Sicurezza elettrica, Electrical safety, Segurança elétrica	-
Presión máxima de servicio (agua), Pression maximale de service, Máxima pressione di esercizio, Maximum operating pressure, Máxima pressão de exercício	2.1 Bar
Resistencia mecánica (para soportar una chimenea/un conducto de humos), Résistance mécanique (pour soutenir la cheminée), Resistenza mecánica (per supportare il camino), Mechanical strength (to support the fireplace), Resistência mecânica (para suportar a chaminé)	Cumple, Conforme, Conforme, Compliant, Em Conformidade
Potencia térmica ambiente, Puissance rendue au milieu, Potenza resa all'ambiente, Power output to the environment, Potência libertada no ambiente	2.5 kW
Potencia térmica agua, Puissance rendue à l'eau, Potenza ceduta all'acqua, Power transferred to water, Potência cedida à água	12 kW
Rendimiento energético, Rendement, Rendimento, Efficiency, Atuação	80 %

Las prestaciones del producto identificado en el punto 1 son conformes con las prestaciones declaradas en el punto 6.

La performance du produit cité au point 1 est conforme à la performance declare au point 6.

La prestazione del prodotto di cui ai punti 1 è conforme alla prestazione dichiarata di cui al punto 6.

The performance of the product referred to in point 1 is consistent with the declared performance in point 6.

As declarações do produto identificado no ponto 1, estão conformes com as prestações declaradas no ponto 6.

La presente declaración de prestaciones se emite bajo la única responsabilidad del fabricante, indicado en el punto 3.

Cette déclaration de performance est délivrée sous la responsabilité exclusive du fabricant cité au point 3.

Si rilascia la presente dichiarazione di prestazione sotto la responsabilità esclusiva del fabricante di cui al punto 3.

This declaration of performance is issued under the manufacturer's sole responsibility referred to in point 3.

É emitida a presente declaração de desempenho sob a responsabilidade exclusiva do fabricante referido no ponto 3.



CH-C-009

DECLARACIÓN DE PRESTACIONES Conforme al R. E. Productos Construcción (UE) N° 305/2011**DÉCLARATION DE PERFORMANCE** Selon le Règlement (UE) N° 305/2011**DICHIARAZIONE DI PRESTAZIONE** In base al Regolamento (UE) N° 305/2011**DECLARATION OF PERFORMANCE** According to Regulation (UE) N° 305/2011**DECLARAÇÃO DE PRESTAÇÕES** Em base com o Regulamento (UE) N° 305/2011

- Nombre y/o código de identificación única del producto:
Nom-code d'identification unique du produit
Nome-codice identificativo unico del prodotto
Unique identifier nome-code for product
Nome-código de identificação único do produto
 - Marca, marque, marca, mark, marca: **Lacunza**
 - Tipo, type, tipo, type, tipo: **Chimenea calefactora, Appareil insérable, Apparecchio a incasso, Insertable appliance, Aparelho encastrável** Modelo, modèle, modello, model, modelo: **SARRIA16 CALEFACTORA, SARRIA16 PLUS CALEFACTORA, SAKAN16 CALEFACTORA, SAKAN16 PLUS CALEFACTORA**
- Uso o usos previstos del producto: Chimenea de carga manual, para quemar combustibles sólidos (indicado en instrucciones), cuya función es calentar el espacio en el que está instalada y proporcionar también agua caliente sanitaria y/o calefacción central.
Utilisation prévue du produit: Appareil insérable qui se charge manuellement, conçu pour brûler des combustibles solides (indiqués dans le Manuel d'Instructions), dont la fonction est de chauffer l'espace où il est installé (et de fournir de l'eau chaude sanitaire et/ou le chauffage central).
Usi previsti del prodotto: Apparecchio a incasso a carico manuale, per bruciare combustibili solidi (indicati nelle istruzioni), la cui funzione è riscaldare lo spazio in cui è installato (e fornire anche acqua calda sanitaria e/o riscaldamento centrale).
Entended uses of the product: Insertable appliance to be loaded by hand and designed to burn solid fuels (indicated in instructions), whose function is to heat the space in which it is installed (and also provide hot water and/or central heating).
Utilização prevista do produto: Aparelho encastrável de carga manual, para queimar combustíveis sólidos (indicado nas instruções), cuja função é aquecer o espaço no qual está instalado (e proporcionar também água quente sanitária e/ou aquecimento central).
- Nombre y dirección del fabricante: **LACUNZA KALOR GROUP S.A.L.**
Nom et adresse du fabricant: **Pol. Ind. Ibarrea s/n 31800 Alsasua (Navarra) (España)**
Nome e indirizzo del fabbricante: **Téléfono: (0034) 948563511**
Name and adress of the manufacturer: **Fax: (0034) 948563505**
Nome e endereço do fabricante: **Email: comercial@lacunza.net**
- Sistema de evaluación y verificación de la constancia de las prestaciones: 3
Système d'évaluation et contrôle de la constante de performance: 3
Sistema di valutazione e verifica della costanza della prestazione: 3
Assessment and verification system for constancy of performance: 3
Sistema de avaliação e verificação da regularidade do desempenho: 3
- Organismo Notificado, Laboratoire notifié, Laboratorio notificato, Laboratory notified, Laboratório notificado: **RRF N° NB1625 Rhein-Ruhr Feuerstätten Prüfstelle GmbH Am Technologie Park 1 D-45307 ESSEN**
Por el sistema, Selon le system, In base al system, Based on system, Em base ao system : 3.
Documento emitido (fecha), Numéro du rapport d'essai (date), Numero rapporto di prova (data), Test report number (date), Número relação de prova (data): **29133304 (15-07-2013)**

6. Prestaciones declaradas, Performance déclarée, Prestazioni dichiarate, Services declare, Desempenhos declarados:

Especificaciones técnicas armonizadas, Spécifications techniques armoniques, Specifica tecnica armonizzata, Harmonised technical specifications, Especifica técnica harmonizada EN13229:2001/A1:2002/A2:2004/AC:2006/AC:2007											
Características esenciales, Caractéristiques essentielles, Caratteristiche essenziali, Essential features, Características essenciais	Prestaciones, Performance, Prestazione, Services, Desempenho										
Reacción al fuego, Resistance au feu, Resistenza al fuoco, Resistance to fire, Resistência ao fogo	Cumple, Conforme, Conforme, Compliant, Em Conformidade										
Distancia mínima de seguridad a materiales combustibles, Distance minimum aux matériaux combustibles, Distanza minima da materiali combustibili, Minimum distance from combustible material, Distância mínimo de materiais combustíveis	<table border="1"> <tr> <td>Izquierda, gauche, sinistra, left, esquerda:</td> <td>200mm</td> </tr> <tr> <td>Derecha, droite, diritto, right, direito:</td> <td>200mm</td> </tr> <tr> <td>Trasera, arrière, retro, back, traseira:</td> <td>200mm</td> </tr> <tr> <td>Delantera, avant, fronte, front, frente:</td> <td>1000mm</td> </tr> <tr> <td>Encimera, dessus, sopra, above, acima:</td> <td>750mm</td> </tr> </table>	Izquierda, gauche, sinistra, left, esquerda:	200mm	Derecha, droite, diritto, right, direito:	200mm	Trasera, arrière, retro, back, traseira:	200mm	Delantera, avant, fronte, front, frente:	1000mm	Encimera, dessus, sopra, above, acima:	750mm
Izquierda, gauche, sinistra, left, esquerda:	200mm										
Derecha, droite, diritto, right, direito:	200mm										
Trasera, arrière, retro, back, traseira:	200mm										
Delantera, avant, fronte, front, frente:	1000mm										
Encimera, dessus, sopra, above, acima:	750mm										
Temperatura humos a potencia térmica nominal, Température des fumées, Temperatura fumi, Fume temperatura, Temperatura dos gases de combustão	289 °C										
Emisión de productos de combustión, Emisión des produits de combustion, Emisión prodotti combustione, Combustión productos emissions, Emissões de produtos de combustão	Cumple, Conforme, Conforme, Compliant, Em Conformidade										
Concentración media CO al 13% O2, Concentration moyenne CO al 13% O2, CO concentrazione media di O2%, Average concentration CO to O2%, CO concentração média de O2%	0.08 %										
Desprendimiento de sustancias peligrosas, Rejet de substances dangereuses, Rilascio di sostanze pericolose, Release of hazardous substances, Lançamento de substâncias perigosas	Cumple, Conforme, Conforme, Compliant, Em Conformidade										
Temperatura superficial, Température de surface, Temperatura superficiale, Surface temperatura, Temperatura superficial	Cumple, Conforme, Conforme, Compliant, Em Conformidade										
Seguridad eléctrica, Sécurité électrique, Sicurezza elettrica, Electrical safety, Segurança elétrica	-										
Presión máxima de servicio (agua), Pression maximale de service, Máxima pressione di esercizio, Maximum operating pressure, Máxima pressão de exercício	2.1 Bar										
Resistencia mecánica (para soportar una chimenea/un conducto de humos), Résistance mécanique (pour soutenir la cheminée), Resistenza mecánica (per supportare il camino), Mechanical strength (to support the fireplace), Resistência mecánica (para suportar a chaminé)	Cumple, Conforme, Conforme, Compliant, Em Conformidade										
Potencia térmica ambiente, Puissance rendue au milieu, Potenza resa all'ambiente, Power output to the environment, Potência libertada no ambiente	3 kW										
Potencia térmica agua, Puissance rendue à l'eau, Potenza ceduta all'acqua, Power transferred to water, Potência cedida à água	16 kW										
Rendimiento energético, Rendement, Rendimento, Efficiency, Atuação	80 %										

Las prestaciones del producto identificado en el punto 1 son conformes con las prestaciones declaradas en el punto 6.
 La performance du produit citée au point 1 est conforme à la performance declare au point 6.
 La prestazione del prodotto di cui al punti 1 è conforme alla prestazione dichiarata di cui al punto 6.
 The performance of the product referred to in point 1 is consistent with the declared performance in point 6.
 As declarações do produto identificado no ponto 1, estão conformes com as prestações declaradas no ponto 6.

La presente declaración de prestaciones se emite bajo la única responsabilidad del fabricante, indicado en el punto 3.
 Cette déclaration de performance est délivrée sous la responsabilité exclusive du fabricant cité au point 3.
 Si rilascia la presente dichiarazione di prestazione sotto la responsabilità esclusiva del fabricante di cui al punto 3.
 This declaration of performance is issued under the manufacturer's sole responsibility referred to in point 3.
 É emitida a presente declaração de desempenho sob a responsabilidade exclusiva do fabricante referido no ponto 3.



Lacunza Kalar Group S. A. L.
 NIF A-31606932
 Polígono Industrial Ibañeta
 31800 Alsasua (Navarra) Spain
José Julián Garcíaandía Pellejero
 Director Gerente

Alsasua 01-07-2013



ES FR EN IT PT DE

N.º CH-C-015B

DECLARACIÓN DE PRESTACIONES

Conforme al R. E. Productos Construcción (UE) N° 305/2011

DÉCLARATION DE PERFORMANCE

Selon le Règlement (UE) N° 305/2011

DECLARATION OF PERFORMANCE

According to Regulation (UE) N° 305/2011

DICHIARAZIONE DI PRESTAZIONE

In base al Regolamento (UE) N° 305/2011

DECLARAÇÃO DE PRESTAÇÕES

Em base com o Regulamento (UE) N° 305/2011

LEISTUNGSERKLÄRUNG

Gemäß R. E. Bauprodukte (EU) Nr. 305/2011

1 Código de identificación única del producto tipo: Code d'identification unique du produit type: Unique identification code of the product-type: Codice di identificazione unico del prodotto-tipo: Código de identificação único do produto-tipo: Eindeutiger Kenncode des Produkttyps:	SARRIA 20	
2 Usos previstos: Usage(s) prévu(s): Intended Usi previsti: Utilização(ões) prevista(s): Verwendungszweck(e):	Aparatos encastrables, incluidos hogares abiertos, alimentados con combustible sólido, para calefacción de edificios residenciales Foyers ouverts et inserts de chauffage domestiques à combustible solide Inset appliances including open fires of residential solid fuel burning Apparecchi da incasso, compresi focolari aperti, alimentati a combustibile solido, per il riscaldamento di edifici residenziali Aparelhos encastrados, incluindo lareiras, alimentados a combustível sólido, para aquecimento de edifícios de habitação Mit festen Brennstoffen betriebene Einbaugeräte, einschließlich offene Feuerstellen, zur Beheizung von Wohngebäuden	
3 Fabricante: Fabricant: Manufacturer:	Fabricante: Fabricant: Hersteller:	LACUNZA KALOR GROUP S.A.L. Pol. Ind. Ibarrea 5A 31800 Alsasua (Navarra) (Spain) T. (0034) 948563511 comercial@lacunza.net
5 Sistemas de evaluación y verificación de la constancia de las prestaciones (EVCP): Système(s) d'évaluation et de vérification de la constance des performances: System/s of AVCP:	Sistemi di VVCP: Sistema(s) de avaliação e verificação da regularidade do desempenho (AVCP): System zur Bewertung und Überprüfung der Leistungsbeständigkeit:	3
6a Norma armonizada: Norme harmonisée: Harmonised standard:	Norma armonizzata: Norma harmonizada: Harmonisierte Norm:	EN-16510-2-2 (2022)
6a Organismos notificados: Organisme(s) notifié(s): Notified body/ies:	Organismi notificati: Organismo(s) notificado(s): Notifizierte Stelle(n):	STROJÍRENSKÝ ZKUŠEBNÍ ÚSTAV, S.P. Engineering Test Institute, Public Enterprise Hudcova 424/56b, 621 00 Brno, Czech Republic. Notified Body 1015

7	Características esenciales Caractéristiques essentielles <i>Essential features</i>	Caratteristiche essenziali Características essenciais <i>Unerlässliche Eigenschaften</i>	Prestaciones declaradas: Performance(s) déclarée(s): <i>Declared performance/s:</i>	Prestazioni dichiarate: Desempenho(s) declarado(s): <i>Erklärte Leistung(en):</i>
----------	---	---	--	--

Protección de materiales combustibles
 Protection des matériaux combustibles
Protection of combustible materials

Protezione dei materiali combustibili
 Proteção de materiais combustíveis
Schutz brennbarer Materialien

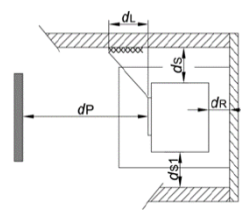
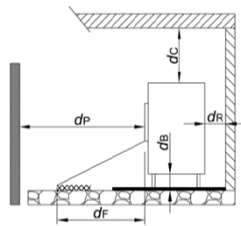

ds =	400 mm	dL =	1500 mm
ds1 =	400 mm	dc =	>750 mm
dR =	400 mm	df =	1500 mm
dP =	1000 mm	db =	0 mm

	A	B
Prestación Declarada a Potencia Calorífica: Performance déclarée à la puissance thermique: Declared Performance at Heating Power: Prestazioni dichiarate alla potenza termica: Desempenho declarado na potência de aquecimento: Angegebene Leistung bei:	Nominal Nominale <i>Nominal</i> Nominal Nominal <i>Nennheizleistung</i>	A carga parcial À charge partielle <i>At partial load</i> A carico parziale Com carga parcial <i>Teillast-Heizleistung</i>
Emisión. Émission. Emission. Emissione. Emissão. Emission CO_{nom} (13%O₂) / CO_{part} (13%O₂)	A 901 mg/m³	B NPD
Emisión. Émission. Emission. Emissione. Emissão. Emission NO_{xnom} (13%O₂) / NO_{xpart} (13%O₂)	A 117 mg/m³	B NPD
Emisión. Émission. Emission. Emissione. Emissão. Emission OGC_{nom} (13%O₂) / OGC_{part} (13%O₂)	A 55 mg/m³	B NPD
Emisión. Émission. Emission. Emissione. Emissão. Emission PM_{nom} (13%O₂) / PM_{part} (13%O₂)	A 35 mg/m³	B NPD
Temperatura de salida de gases de combustión (TS _{nom} /TS _{part}) Température de sortie des gaz de combustion (TS _{nom} /TS _{part}) Combustion gas outlet temperature (TS_{nom}/TS_{part}) Temperatura uscita gas di combustione (TS _{nom} /TS _{part}) Temperatura de saída do gás de combustão (TS _{nom} /TS _{part}) Verbrennungsgasaustrittstemperatur (TS _{nom} /TS _{part})	A 312 °C	B NPD
Tiro mínimo (P_{nom}/P_{part}) Tirage minimum (P_{nom}/P_{part}) Minimum depression	A 12 Pa	B NPD
Depressione minima (P_{nom}/P_{part}) Depressão mínima (P_{nom}/P_{part}) Minimale depression (P_{nom}/P_{part})		
Caudal máxico de los gases de combustión (ϕ _{f,gnom} /ϕ _{f,gpart}) Débit massique des gaz de combustion (ϕ _{f,gnom} /ϕ _{f,gpart}) Mass flow rate of combustion gases (ϕ_{f,gnom}/ϕ_{f,gpart}) Portata massica dei gas di combustione (ϕ _{f,gnom} /ϕ _{f,gpart}) Taxa de fluxo de massa de gases de combustão (ϕ _{f,gnom} /ϕ _{f,gpart}) Massenstrom der Verbrennungsgase (ϕ _{f,gnom} /ϕ _{f,gpart})	A 16.2 g/s	B NPD
Seguridad contra incendios de instalaciones en una chimenea (T_{class}) Sécurité incendie des installations dans une cheminée (T_{class}) Fire safety of installations in a chimney (T_{class}) Sicurezza antincendio delle installazioni (T_{class}) Segurança contra incêndio de instalações em chaminé (T_{class}) Brandschutz von Anlagen in einem Schornstein (T_{class})	T400	

Potencia de calefacción (P _{nom} /P _{part}) Puissance de chauffe (P _{nom} /P _{part}) Heating power (P _{nom} /P _{part})	Potenza di riscaldamento (P _{nom} /P _{part}) Potência de aquecimento (P _{nom} /P _{part}) Heizleistung (P _{nom} /P _{part})	A	20 kW	B	NPD
Potencia de calentamiento de agua (P _{Wnom} /P _{Wpart}) Puissance de chauffage de l'eau (P _{Wnom} /P _{Wpart}) Water heating power (P _{Wnom} /P _{Wpart})	Potenza di riscaldamento dell'acqua (P _{Wnom} /P _{Wpart}) Potência de aquecimento (P _{Wnom} /P _{Wpart}) Wasserheizleistung (P _{Wnom} /P _{Wpart})	A	13.4 kW	B	NPD
Eficiencia (η _{nom} /η _{part}) Efficacité (η _{nom} /η _{part}) Efficiency (η _{nom} /η _{part})	Efficiencia (η _{nom} /η _{part}) Eficiência (η _{nom} /η _{part}) Effizienz (η _{nom} /η _{part})	A	81 %	B	NPD
Eficiencia de calefacción estacional (η _s) Efficacité du chauffage saisonnier (η _s) Seasonal heating efficiency (η _s)	Efficiencia térmica stagionale (η _s) Eficiência de aquecimento sazonal (η _s) Saisonale Heizeffizienz (η _s)	71			
Índice eficiencia energética (EEI) Indice d'efficacité énergétique (EEI) Energy efficiency index (EEI)	Índice de eficiencia energética (EEI) Índice de eficiência energética (EEI) Energieeffizienzindex (EEI)	107			
Clase Classe Class	Clase Classe Klasse	A+			
Consumo de energía eléctrica (elmáx / elmín) Consommation d'énergie électrique (elmáx / elmín) Electrical energy consumption (elmáx / elmín) Consumo di energia elettrica (elmáx / elmín) Consumo de energia elétrica (elmáx / elmín) Elektrischer Energieverbrauch (elmáx / elmín)		A	NPD	B	NPD
Consumo de energía modo espera (elsb) Consommation d'énergie en veille (elsb) Standby power consumption (elsb)	Consumo energético in standby (elsb) Consumo de energia em espera (elsb) Standby-Strømverbrauch (elsb)	NPD			
Sostenibilidad medioambiental La durabilité environnementale Environmental sustainability	Sostenibilità ambientale Sustentabilidade ambiental Umweltverträglichkeit				

Las prestaciones del producto identificado anteriormente son conformes con el conjunto de las prestaciones declaradas.
Les performances du produit identifié ci-dessus sont conformes à toutes les performances déclarées.
The performances of the product identified above are in accordance with all the declared performances.

Le prestazioni del prodotto sopra identificato sono conformi a tutte le prestazioni dichiarate.
Os desempenhos do produto acima identificados estão de acordo com todos os desempenhos declarados.
Die oben genannten Leistungen des Produkts entsprechen allen erklärten Leistungen.

La presente declaración de prestaciones se emite, de conformidad con el Reglamento (UE) n.º 305/2011, bajo la sola responsabilidad del fabricante arriba identificado.
Cette déclaration des performances est établie, conformément au Règlement (UE) n.º 305/2011, sous la seule responsabilité du fabricant identifié ci-dessus.
This declaration of performance is issued, in accordance with Regulation (EU) No. 305/2011, under the sole responsibility of the manufacturer identified above.

La presente dichiarazione di prestazione viene rilasciata, in conformità al Regolamento (UE) n. 305/2011, sotto la responsabilità esclusiva del produttore sopra identificato.
Esta declaração de desempenho é emitida, de acordo com o Regulamento (UE) n.º 305/2011, sob a exclusiva responsabilidade do fabricante acima identificado.
Die Erstellung dieser Leistungserklärung erfolgt gemäß Verordnung (EU) Nr. 305/2011 in alleiniger Verantwortung des oben genannten Herstellers.



LACUNZA KALOR GROUP S.A.L.
Pol. Ind. Ibarrea SA 31800
Alsasua (Navarra) (Spain)
T. (0034) 948563511
comercial@lacunza.net
www.lacunza.net

Firmado por y en nombre del fabricante por:
Signé pour le fabricant et en son nom par:
Signed for and on behalf of the manufacturer by:
Firmato a nome e per conto del fabbricante da:
Assinado por e em nome do fabricante por:
Unterzeichnet für den Hersteller und im Namen des Herstellers von :

ALSASUA (Navarra, Spain) a 25/05/2026



Igor Ruiz de Alegria
Director Gerente de Negocio



ES FR EN IT PT DE

N.º CH-C-015B
DECLARACIÓN DE PRESTACIONES

Conforme al R. E. Productos Construcción (UE) N° 305/2011

DÉCLARATION DE PERFORMANCE

Selon le Règlement (UE) N° 305/2011

DECLARATION OF PERFORMANCE

According to Regulation (UE) N° 305/2011

DICHIARAZIONE DI PRESTAZIONE

In base al Regolamento (UE) N° 305/2011

DECLARAÇÃO DE PRESTAÇÕES

Em base com o Regulamento (UE) N° 305/2011

LEISTUNGSERKLÄRUNG

Gemäß R. E. Bauprodukte (EU) Nr. 305/2011

1 Código de identificación única del producto tipo: Code d'identification unique du produit type: <i>Unique identification code of the product-type:</i> Codice di identificazione unico del prodotto-tipo: Código de identificação único do produto-tipo: <i>Eindeutiger Kenncode des Produkttyps:</i>	SAKAN 20	
2 Usos previstos: Usage(s) prévu(s): <i>Intended</i> Usi previsti: Utilização(ões) prevista(s): <i>Verwendungszweck(e):</i>	Aparatos encastrables, incluidos hogares abiertos, alimentados con combustible sólido, para calefacción de edificios residenciales Foyers ouverts et inserts de chauffage domestiques à combustible solide Inset appliances including open fires of residential solid fuel burning Apparecchi da incasso, compresi focolari aperti, alimentati a combustibile solido, per il riscaldamento di edifici residenziali Aparelhos encastrados, incluindo lareiras, alimentados a combustível sólido, para aquecimento de edifícios de habitação Mit festen Brennstoffen betriebene Einbaugeräte, einschließlich offene Feuerstellen, zur Beheizung von Wohngebäuden	
3 Fabricante: Fabricant: <i>Manufacturer:</i>	Fabricante: Fabricant: <i>Hersteller:</i>	LACUNZA KALOR GROUP S.A.L. Pol. Ind. Ibarrea 5A 31800 Alsasua (Navarra) (Spain) T. (0034) 948563511 comercial@lacunza.net
5 Sistemas de evaluación y verificación de la constancia de las prestaciones (EVCP): Système(s) d'évaluation et de vérification de la constance des performances: <i>System/s of AVCP:</i>	Sistemi di VVCP: Sistema(s) de avaliação e verificação da regularidade do desempenho (AVCP): System zur Bewertung und Überprüfung der Leistungsbeständigkeit:	3
6a Norma armonizada: Norme harmonisée: <i>Harmonised standard:</i>	Norma armonizzata: Norma harmonizada: <i>Harmonisierte Norm:</i>	EN-16510-2-2 (2022)
6a Organismos notificados: Organisme(s) notifié(s): <i>Notified body/ies:</i>	Organismi notificati: Organismo(s) notificado(s): <i>Notifizierte Stelle(n):</i>	STROJÍRENSKÝ ZKUŠEBNÍ ÚSTAV, S.P. Engineering Test Institute, Public Enterprise Hudcova 424/56b, 621 00 Brno, Czech Republic. Notified Body 1015

7	Características esenciales Caractéristiques essentielles <i>Essential features</i>	Caratteristiche essenziali Características essenciais <i>Unerlässliche Eigenschaften</i>	Prestaciones declaradas: Performance(s) déclarée(s): <i>Declared performance/s:</i>	Prestazioni dichiarate: Desempenho(s) declarado(s): <i>Erklärte Leistung(en):</i>
----------	---	---	--	--

Protección de materiales combustibles
 Protection des matériaux combustibles
Protection of combustible materials

Protezione dei materiali combustibili
 Proteção de materiais combustíveis
Schutz brennbarer Materialien

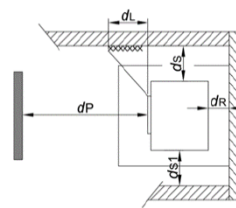
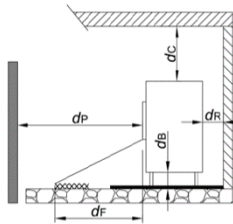

ds =	400 mm	dL =	1500 mm
ds1 =	400 mm	dc =	>750 mm
dR =	400 mm	dF =	1500 mm
dP =	1000 mm	dB =	0 mm

	A	B
Prestación Declarada a Potencia Calorífica: Performance déclarée à la puissance thermique: <i>Declared Performance at Heating Power:</i> Prestazioni dichiarate alla potenza termica: Desempenho declarado na potência de aquecimento: <i>Angegebene Leistung bei:</i>	Nominal Nominale Nominal Nominale Nominal	A carga parcial À charge partielle At partial load A carico parziale Com carga parcial Teillast-Heizleistung
Emisión. Émission. Emission. Emissione. Emissão. Emission CO_{nom} (13%O₂) / CO_{part} (13%O₂)	A 901 mg/m³	B NPD
Emisión. Émission. Emission. Emissione. Emissão. Emission NO_{xnom} (13%O₂) / NO_{xpart} (13%O₂)	A 117 mg/m³	B NPD
Emisión. Émission. Emission. Emissione. Emissão. Emission OGC_{nom} (13%O₂) / OGC_{part} (13%O₂)	A 55 mg/m³	B NPD
Emisión. Émission. Emission. Emissione. Emissão. Emission PM_{nom} (13%O₂) / PM_{part} (13%O₂)	A 35 mg/m³	B NPD
Temperatura de salida de gases de combustión (TS _{nom} /TS _{part}) Température de sortie des gaz de combustion (TS _{nom} /TS _{part}) <i>Combustion gas outlet temperature (TS_{nom}/TS_{part})</i> Temperatura uscita gas di combustione (TS _{nom} /TS _{part}) Temperatura de saída do gás de combustão (TS _{nom} /TS _{part}) Verbrennungsgasaustrittstemperatur (TS _{nom} /TS _{part})	A 312 °C	B NPD
Tiro mínimo (P _{nom} /P _{part}) Tirage minimum (P _{nom} /P _{part}) <i>Minimum depression</i>	A 12 Pa	B NPD
Depressione minima (P _{nom} /P _{part}) Depressão mínima (P _{nom} /P _{part}) <i>Minimale depression (P_{nom}/P_{part})</i>		
Caudal máxico de los gases de combustión (Ø _{f,gnom} /Ø _{f,gpart}) Débit massique des gaz de combustion (Ø _{f,gnom} /Ø _{f,gpart}) <i>Mass flow rate of combustion gases (Ø_{f,gnom}/Ø_{f,gpart})</i> Portata massica dei gas di combustione (Ø _{f,gnom} /Ø _{f,gpart}) Taxa de fluxo de massa de gases de combustão (Ø _{f,gnom} /Ø _{f,gpart}) Massenstrom der Verbrennungsgase (Ø _{f,gnom} /Ø _{f,gpart})	A 16.2 g/s	B NPD
Seguridad contra incendios de instalaciones en una chimenea (T _{class}) Sécurité incendie des installations dans une cheminée (T _{class}) <i>Fire safety of installations in a chimney (T_{class})</i> Sicurezza antincendio delle installazioni (T _{class}) Segurança contra incêndio de instalações em chaminé (T _{class}) Brandschutz von Anlagen in einem Schornstein (T _{class})	T400	

Potencia de calefacción (P _{nom} /P _{part}) Puissance de chauffe (P _{nom} /P _{part}) Heating power (P _{nom} /P _{part})	Potenza di riscaldamento (P _{nom} /P _{part}) Potência de aquecimento (P _{nom} /P _{part}) Heizleistung (P _{nom} /P _{part})	A	20 kW	B	NPD
Potencia de calentamiento de agua (P _{Wnom} /P _{Wpart}) Puissance de chauffage de l'eau (P _{Wnom} /P _{Wpart}) Water heating power (P _{Wnom} /P _{Wpart})	Potenza di riscaldamento dell'acqua (P _{Wnom} /P _{Wpart}) Potência de aquecimento (P _{Wnom} /P _{Wpart}) Wasserheizleistung (P _{Wnom} /P _{Wpart})	A	13.4 kW	B	NPD
Eficiencia (η _{nom} /η _{part}) Efficacité (η _{nom} /η _{part}) Efficiency (η _{nom} /η _{part})	Eficiencia (η _{nom} /η _{part}) Eficiência (η _{nom} /η _{part}) Effizienz (η _{nom} /η _{part})	A	81 %	B	NPD
Eficiencia de calefacción estacional (η _s) Efficacité du chauffage saisonnier (η _s) Seasonal heating efficiency (η _s)	Eficiencia térmica stagionale (η _s) Eficiência de aquecimento sazonal (η _s) Saisonale Heizeffizienz (η _s)		71		
Índice eficiencia energética (EEI) Indice d'efficacité énergétique (EEI) Energy efficiency index (EEI)	Índice de eficiencia energética (EEI) Índice de eficiência energética (EEI) Energieeffizienzindex (EEI)		107		
Clase Classe Class	Clase Classe Klasse		A+		
Consumo de energía eléctrica (elm _{ax} / elm _{in}) Consommation d'énergie électrique (elm _{ax} / elm _{in}) Electrical energy consumption (elm _{ax} / elm _{in})	Consumo di energia elettrica (elm _{ax} / elm _{in}) Consumo de energia elétrica (elm _{ax} / elm _{in}) Elektrischer Energieverbrauch (elm _{ax} / elm _{in})	A	NPD	B	NPD
Consumo de energía modo espera (elsb) Consommation d'énergie en veille (elsb) Standby power consumption (elsb)	Consumo energético in standby (elsb) Consumo de energia em espera (elsb) Standby-Stromverbrauch (elsb)		NPD		
Sostenibilidad medioambiental La durabilité environnementale Environmental sustainability	Sostenibilità ambientale Sustentabilidade ambiental Umweltverträglichkeit				

Las prestaciones del producto identificado anteriormente son conformes con el conjunto de las prestaciones declaradas.
Les performances du produit identifié ci-dessus sont conformes à toutes les performances déclarées.
The performances of the product identified above are in accordance with all the declared performances.

Le prestazioni del prodotto sopra identificato sono conformi a tutte le prestazioni dichiarate.
Os desempenhos do produto acima identificados estão de acordo com todos os desempenhos declarados.
Die oben genannten Leistungen des Produkts entsprechen allen erklärten Leistungen.

La presente declaración de prestaciones se emite, de conformidad con el Reglamento (UE) n.º 305/2011, bajo la sola responsabilidad del fabricante arriba identificado.
Cette déclaration des performances est établie, conformément au Règlement (UE) n.º 305/2011, sous la seule responsabilité du fabricant identifié ci-dessus.
This declaration of performance is issued, in accordance with Regulation (EU) No. 305/2011, under the sole responsibility of the manufacturer identified above.

La presente dichiarazione di prestazione viene rilasciata, in conformità al Regolamento (UE) n. 305/2011, sotto la responsabilità esclusiva del produttore sopra identificato.
Esta declaração de desempenho é emitida, de acordo com o Regulamento (UE) n.º 305/2011, sob a exclusiva responsabilidade do fabricante acima identificado.
Die Erstellung dieser Leistungserklärung erfolgt gemäß Verordnung (EU) Nr. 305/2011 in alleiniger Verantwortung des oben genannten Herstellers.



LACUNZA KALOR GROUP S.A.L.
Pol. Ind. Ibarrea SA 31800
Alsasua (Navarra) (Spain)
T. (0034) 948563511
comercial@lacunza.net
www.lacunza.net

Firmado por y en nombre del fabricante por:
Signé pour le fabricant et en son nom par:
Signed for and on behalf of the manufacturer by:
Firmato a nome e per conto del fabbricante da:
Assinado por e em nome do fabricante por:
Unterzeichnet für den Hersteller und im Namen des Herstellers von :

ALSASUA (Navarra, Spain) a 25/05/2026





Igor Ruiz de Alegria
Director Gerente de Negocio

9. CE MARK

		LACUNZA KALOR GROUP S.A.L. Pol. Ind. Ibarrea s/n 31800 Alsasua (Navarra) (Spain)
		Número, Nombre, Numero, Number, Número : CH-C-007
Marca, marque, marca, mark, marca: Lacunza Tipo, type, tipo, type, tipo: Chimenea Calefactora, Appareil insérable, Apparecchio a incasso, Insertable appliance, Aparelho encastrável Modelo, modèle, modello, model, modelo: Sarria12 Calefactora, Sarria12 Plus Calefactora, Sakan12 Calefactora, Sakan12 Plus Calefactora		Organismo notificado, Laboratoire notifié, Laboratorio notificato, Laboratory notified, Laboratorio notificado: RRF N° NB1625
Chimenea de carga manual, para quemar combustibles sólidos (indicado en instrucciones), cuya función es calentar el espacio en el que está instalado y proporcionar también agua caliente sanitaria y/o calefacción central. Appareil insérable qui se charge manuellement, conçu pour brûler des combustibles solides (indiqués dans le Manuel d'Instructions), dont la fonction est de chauffer l'espace où il est installé (et de fournir de l'eau chaude sanitaire et/ou le chauffage central). Apparecchio a incasso a carico manuale, per bruciare combustibili solidi (indicati nelle istruzioni), la cui funzione è riscaldare lo spazio in cui è installato (e fornire anche acqua calda sanitaria e/o riscaldamento centrale). Insertable appliance to be loaded by hand and designed to burn solid fuels (indicated in instructions), whose function is to heat the space in which it is installed (and also provide hot water and/or central heating). Aparelho encastrável de carga manual, para queimar combustíveis sólidos (indicado nas instruções), cuja função é aquecer o espaço no qual está instalado (e proporcionar também água quente sanitária e/ou aquecimento central).		
EN13229:2001/A1:2002/A2:2004/AC:2006/AC:2007		
Características esenciales, Caractéristiques essentielles, Caratteristiche essenziali, Essential features, Características essenciais		Prestaciones, Performance, Prestazione, Services, Desempenho
Reacción al fuego, Resistance au feu, Resistenza al fuoco, Resistance to fire, Resistência ao fogo		Cumple, Conforme, Conforme, Compliant, Em Conformidade
Distancia mínima de seguridad a materiales combustibles, Distance minimum aux matériaux combustibles, Distanza minima da materiali combustibili, Minimum distance from combustible material, Distância mínimo de materiais combustíveis	Izquierda, gauche, sinistra, left, esquerda: 200mm Derecha, droite, diritto, right, direito: 200mm Trasera, arrière, retro, back, traseira: 200mm Delantera, avant, fronte, front, frente: 1000mm Encimera, dessus, sopra, above, acima: 750mm	
Temperatura humos a potencia térmica nominal, Température des fumées, Temperatura fumi, Fume temperatura, Temperatura dos gases de combustão	284 °C	
Emisión productos combustión, Emisión des produits de combustion, Emisión prodotti combustione, Combustión productos emissions, Emissões de produtos de combustão	Cumple, Conforme, Conforme, Compliant, Em Conformidade	
Concentración media CO al 13% O2, Concentration moyenne CO al 13% O2, CO concentrazione media di O2%, Average concentration CO to O2%, CO concentração média de O2%	0.07 %	
Desprendimiento de sustancias peligrosas, Rejet de substances dangereuses, Rilascio di sostanze pericolose, Release of hazardous substances, Lançamento de substâncias perigosas	Cumple, Conforme, Conforme, Compliant, Em Conformidade	
Temperatura superficial, Température de surface, Temperatura superficiale, Surface temperatura, Temperatura superficial	Cumple, Conforme, Conforme, Compliant, Em Conformidade	
Seguridad eléctrica, Sécurité électrique, Sicurezza elettrica, Electrical safety, Segurança elétrica	-	
Presión máxima de servicio (agua), Pression maximale de service, Máxima pressione di esercizio, Maximum operating pressure, Máxima pressão de exercício	2.1 Bar	
Resistencia mecánica (para soportar una chimenea/un conducto de humos), Resistanse mécanique (pour soutenir la cheminée), Resistenza mecánica (per supportare il camino), Mechanical strength (to support the fireplace), Resistência mecánica (para suportar a chaminé)	Cumple, Conforme, Conforme, Compliant, Em Conformidade	
Potencia térmica ambiente, Puissance rendue au milieu, Potenza resa all'ambiente, Power output to the environment, Potência libertada no ambiente	2.5 kW	
Potencia térmica agua, Puissance rendue à l'eau, Potenza ceduta all'acqua, Power transferred to wáter, Potência cedida à água	12 kW	
Rendimiento energético, Rendement, Rendimento, Efficiency, Atuação	80 %	

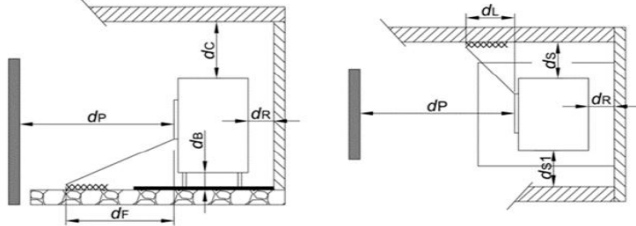
 13	LACUNZA KALOR GROUP S.A.L. Pol. Ind. Ibarrea s/n 31800 Alsasua (Navarra) (Spain)
	Número, Nombre, Numero, Number, Número : CH-C-009
Marca, marque, marca, mark, marca: Lacunza Tipo, type, tipo, type, tipo: Chimenea Calefactora, Appareil insérable, Apparecchio a incasso, Insertable appliance, Aparelho encastrável Modelo, modèle, modello, model, modelo: Sarria16 Calefactora, Sarria16 Plus Calefactora, Sakan16 Calefactora, Sakan16 Plus Calefactora	Organismo notificado, Laboratoire notifié, Laboratorio notificato, Laboratory notified, Laboratorio notificado: RRF N° NB1625
<p>Chimenea de carga manual, para quemar combustibles sólidos (indicado en instrucciones), cuya función es calentar el espacio en el que está instalado y proporcionar también agua caliente sanitaria y/o calefacción central.</p> <p>Appareil insérable qui se charge manuellement, conçu pour brûler des combustibles solides (indiqués dans le Manuel d'Instructions), dont la fonction est de chauffer l'espace où il est installé (et de fournir de l'eau chaude sanitaire et/ou le chauffage central).</p> <p>Apparecchio a incasso a carico manuale, per bruciare combustibili solidi (indicati nelle istruzioni), la cui funzione è riscaldare lo spazio in cui è installato (e fornire anche acqua calda sanitaria e/o riscaldamento centrale).</p> <p>Insertable appliance to be loaded by hand and designed to burn solid fuels (indicated in instructions), whose function is to heat the space in which it is installed (and also provide hot water and/or central heating).</p> <p>Aparelho encastrável de carga manual, para queimar combustíveis sólidos (indicado nas instruções), cuja função é aquecer o espaço no qual está instalado (e proporcionar também água quente sanitária e/ou aquecimento central).</p>	
EN13229:2001/A1:2002/A2:2004/AC:2006/AC:2007	
Características esenciales, Caractéristiques essentielles, Caratteristiche essenziali, Essential features, Características essenciais	Prestaciones, Performance, Prestazione, Services, Desempenho
Reacción al fuego, Resistance au feu, Resistenza al fuoco, Resistance to fire, Resistência ao fogo	Cumple, Conforme, Conforme, Compliant, Em Conformidade
Distancia mínima de seguridad a materiales combustibles, Distance minimum aux matériaux combustibles, Distanza minima da materiali combustibili, Minimum distance from combustible material, Distância mínimo de materiais combustíveis	Izquierda, gauche, sinistra, left, esquerda: 200mm Derecha, droite, diritto, right, direito: 200mm Trasera, arrière, retro, back, traseira: 200mm Delantera, avant, fronte, front, frente: 1000mm Encimera, dessus, sopra, above, acima: 750mm
Temperatura humos a potencia térmica nominal, Température des fumées, Temperatura fumi, Fume temperatura, Temperatura dos gases de combustão	289 °C
Emisión productos combustión, Emisión des produits de combustion, Emisión prodotti combustione, Combustión productos emissions, Emissões de produtos de combustão	Cumple, Conforme, Conforme, Compliant, Em Conformidade
Concentración media CO al 13% O2, Concentration moyenne CO al 13% O2, CO concentrazione media di O2%, Average concentration CO to O2%, CO concentração média de O2%	0.08 %
Desprendimiento de sustancias peligrosas, Rejet de substances dangereuses, Rilascio di sostanze pericolose, Release of hazardous substances, Lançamento de substâncias perigosas	Cumple, Conforme, Conforme, Compliant, Em Conformidade
Temperatura superficial, Température de surface, Temperatura superficiale, Surface temperatura, Temperatura superficial	Cumple, Conforme, Conforme, Compliant, Em Conformidade
Seguridad eléctrica, Sécurité électrique, Sicurezza elettrica, Electrical safety, Segurança elétrica	-
Presión máxima de servicio (agua), Pression maximale de service, Máxima pressione di esercizio, Maximum operating pressure, Máxima pressão de exercício	2.1 Bar
Resistencia mecánica (para soportar una chimenea/un conducto de humos), Résistance mécanique (pour soutenir la cheminée), Resistenza mecánica (per supportare il camino), Mechanical strength (to support the fireplace), Resistência mecânica (para suportar a chaminé)	Cumple, Conforme, Conforme, Compliant, Em Conformidade
Potencia térmica ambiente, Puissance rendue au milieu, Potenza resa all'ambiente, Power output to the environment, Potência libertada no ambiente	3 kW
Potencia térmica agua, Puissance rendue à l'eau, Potenza ceduta all'acqua, Power transferred to water, Potência cedida à água	16 kW
Rendimiento energético, Rendement, Rendimento, Efficiency, Atuação	80 %

	LACUNZA KALOR GROUP S.A.L. Pol. Ind. Ibarrea 5A 31800 Alsasua (Navarra) (Spain) www.lacunza.net	
	DoP: CH-C-015B	EN 16510-2-2 (2022)
Marca, Marque, Mark, Marca, Marca, Markierung: LACUNZA Tipo, Type, Type, Tipo, Tipo, Nett: Insertable, Appareil insérable, Apparecchio a incasso, Insertable appliance, Aparelho encastrável Modelo, Modèle, Model, Modello, Modelo, Modell: SARRIA 20		
Organismo notificado: Organisme notifié: Notified body: Organismi notificati: Organismo notificado: Notifizierte Stelle: SZU N° 1015		
Aparato Tipo, Type d'appareil, Apparatus Type, Tipo di apparecchio, Tipo de aparelho, Gerätetyp: B		
Estufa de calefacción residencial, alimentada con combustibles sólidos. Poêles de chauffage domestiques à combustible solide. Residential solid fuel burning Roomheaters. Stufa di riscaldamento domestici a combustibile solido. Fogão de aquecimento residencial, alimentado por combustíveis sólidos. Häusliche Raumheizer für feste Brennstoffe.		
Características esenciales, Caractéristiques essentielles, Essential features, Caratteristiche essenziali, Características essenciais, Unerlässliche Eigenschaften		Prestaciones, Performance, Prestazione, Services, Desempenno, Leistungen
Capacidad para soportar carga, Capacité de chargement, Load bearing capacity, Capacità di carico, Capacidade de carga, Tragfähigkeit		NPD
Protección de materiales combustibles. Protection des matériaux combustibles. Protection of combustible materials. Proteção de materiais combustíveis. Schutz brennbarer Materialien		dS = 400mm dS1 = 400mm dR = 400mm dP = 1000mm dL = 1500mm dC > 750mm dF = 1500mm dB = 0mm
		
Prestación Declarada a Potencia Calorífica: Performance déclarée à la puissance thermique: Declared Performance at Heating Power: Prestazioni dichiarate alla potenza termica: Desempenho declarado na potência de aquecimento: Angegebene Leistung bei:		Nominal Nominale Nominale Nominale Nennheizleistung
		A carga parcial À charge partielle At partial load A carico parziale Com carga parcial Teillast- Heizleistung
Emisión. Émission. Emission. Emissione. Emissão. Emission CO_{nom} (13%O₂) / CO_{part} (13%O₂)		901 mg/m ³
Emisión. Émission. Emission. Emissione. Emissão. Emission NO_{xnom} (13%O₂)/NO_{xpart} (13%O₂)		117 mg/m ³
Emisión. Émission. Emission. Emissione. Emissão. Emission OG_{Cnom} (13%O₂)/OG_{Cpart} (13%O₂)		55 mg/m ³
Emisión. Émission. Emission. Emissione. Emissão. Emission PM_{nom} (13%O₂) / PM_{part} (13%O₂)		35 mg/m ³
Temperatura de salida de gases de combustión. Température de sortie des gaz de combustion. Combustion gas outlet temperature. Temperatura uscita gas di combustione. Temperatura de saída do gás de combustão. Verbrennungsgasaustrittstemperatur. (TS_{nom}/TS_{part})		312 °C
Tiro mínimo. Tirage minimum. Minimum depression. Depressione minima. Depressão mínima. Minimale depression (P_{nom}/P_{part})		12 Pa
Caudal máxico de los gases de combustión. Débit massique des gaz de combustion. Mass flow rate of combustion gases. Portata massica dei gas di combustione. Taxa de fluxo de massa de gases de combustão. Massenstrom der Verbrennungsgase (Øf, g_{nom}/Øf, g_{part})		16.2 g/s
Seguridad contra incendios de instalaciones en una chimenea. Sécurité incendie des installations dans une cheminée. Fire safety of installations in a chimney. Sicurezza antincendio delle installazioni. Segurança contra incêndio de instalações em chaminé. Brandschutz von Anlagen in einem Schornstein (Tclass)		T400
Potencia de calefacción. Puissance de chauffe. Heating power. Potenza di riscaldamento. Potência de aquecimento. Heizleistung (P_{nom}/P_{part})		20 kW
Potencia de calentamiento de agua. Pissance de chauffage de l'eau. Water heating power. Potenza di riscaldamento del l'acqua. Potência de aquecimento. Wasserheizleistung (PW_{nom}/PW_{part})		13.4 kW
Eficiencia. Efficacité. Efficiency. Efficienza. Eficiência. Effizienz (η_{nom}/η_{part})		81 %
Eficiencia de calefacción estacional. Efficacité du chauffage saisonnier. Seasonal heating efficiency. Efficienza térmica stagionale. Eficiência de aquecimento sazonal. Saisonale Heizeffizienz (η_s)		71 %
Índice eficiencia energética. Indice d'efficacité énergétique. Energy efficiency index. Índice de eficiencia energética. Índice de eficiência energética. Energieeffizienzindex (EEI)		107
Clase. Classe. Class. Classe. Klasse		A+
Consumo de energía eléctrica. Consommation d'énergie électrique. Electrical energy consumption. Consumo di energia elettrica. Consumo de energia elétrica. Elektrischer Energieverbrauch (elmáx / elmin)		NPD
Consumo de energía modo espera. Consommation d'énergie en veille. Standby power consumption. Consumo energético in standby. Consumo de energia em espera. Standby-Stromverbrauch (elsb)		NPD

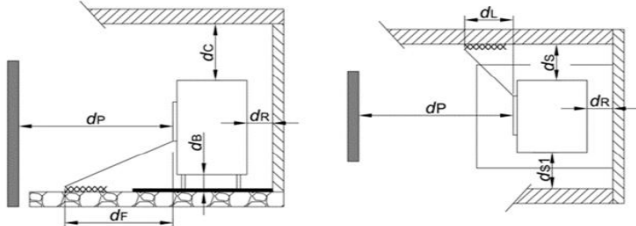
 16	LACUNZA KALOR GROUP S.A.L. Pol. Ind. Ibarrea 5A 31800 Alsasua (Navarra) (Spain) www.lacunza.net	
	DoP: CH-C-015B	EN 16510-2-2 (2022)
Marca, Marque, Mark, Marca, Marca, Markierung: LACUNZA Tipo, Type, Type, Tipo, Tipo, Nett: Insertable, Appareil insérable, Apparecchio a incasso, Insertable appliance, Aparelho encastrável Modelo, Modèle, Model, Modello, Modelo, Modell: SAKAN 20		
Organismo notificado: Organisme notifié: Notified body: Organismi notificati: Organismo notificado: Notifizierte Stelle: SZU N° 1015 Aparato Tipo, Type d'appareil, Apparatus Type, Tipo di apparecchio, Tipo de aparelho, Gerätetyp: B		
Estufa de calefacción residencial, alimentada con combustibles sólidos. Poêles de chauffage domestiques à combustible solid. Residential solid fuel burning Roomheaters. Stufa di riscaldamento domestici a combustibile solido. Fogão de aquecimento residencial, alimentado por combustíveis sólidos. Häusliche Raumheizer für feste Brennstoffe.		
Características esenciales, Caractéristiques essentielles, Essential features, Caratteristiche essenziali, Características essenciais, Unerlässliche Eigenschaften	Prestaciones, Performance, Prestazione, Services, Desempenho, Leistungen	
Capacidad para soportar carga, Capacité de chargement, Load bearing capacity, Capacità di carico, Capacidade de carga, Tragfähigkeit		NPD
Protección de materiales combustibles. Protection des matériaux combustibles. Protection of combustible materials. Protezione dei materiali combustibili. Proteção de materiais combustíveis. Schutz brennbarer Materialien		dS = 400mm dS1 = 400mm dR = 400mm dP = 1000mm dL = 1500mm dC > 750mm dF = 1500mm dB = 0mm
		
Prestación Declarada a Potencia Calorífica: Performance déclarée à la puissance thermique: Declared Performance at Heating Power: Prestazioni dichiarate alla potenza termica: Desempenho declarado na potência de aquecimento: Angegebene Leistung bei:		Nominal Nominale Nominale Nominale Nennheizleistung
Emisión. Émission. Emission. Emissione. Emissão. Emission CO_{nom} (13%O₂) / CO_{part} (13%O₂)		A carga parcial À charge partielle At partial load A carico parziale Com carga parcial Teillast- Heizleistung
Emisión. Émission. Emission. Emissione. Emissão. Emission NO_{xnom} (13%O₂)/NO_{xpart} (13%O₂)		901 mg/m³
Emisión. Émission. Emission. Emissione. Emissão. Emission NO_{xnom} (13%O₂)/NO_{xpart} (13%O₂)		117 mg/m³
Emisión. Émission. Emission. Emissione. Emissão. Emission OGC_{nom} (13%O₂)/OGC_{part} (13%O₂)		55 mg/m³
Emisión. Émission. Emission. Emissione. Emissão. Emission PM_{nom} (13%O₂) / PM_{part} (13%O₂)		35 mg/m³
Temperatura de salida de gases de combustión. Température de sortie des gaz de combustion. Combustion gas outlet temperature. Temperatura uscita gas di combustione. Temperatura de saída do gás de combustão. Verbrennungsgasaustrittstemperatur. (TS_{nom}/TS_{part})		312 °C
Tiro mínimo. Tirage minimum. Minimum depression. Depressione minima. Depressão mínima. Minimale depression (P_{nom}/P_{part})		12 Pa
Caudal máxico de los gases de combustión. Débit massique des gaz de combustion. Mass flow rate of combustion gases. Portata massica dei gas di combustion. Taxa de fluxo de massa de gases de combustão. Massenstrom der Verbrennungsgase (Øf.g_{nom}/Øf.g_{part})		16.2 g/s
Seguridad contra incendios de instalaciones en una chimenea. Sécurité incendie des installations dans une cheminée. Fire safety of installations in a chimney. Sicurezza antincendio delle installazioni. Segurança contra incêndio de instalações em chaminé. Brandschutz von Anlagen in einem Schornstein (Tclass)		T400
Potencia de calefacción. Puissance de chauffe. Heating power. Potenza di riscaldamento. Potência de aquecimento. Heizleistung (P_{nom}/P_{part})		20 kW
Potencia de calentamiento de agua. Pussance de chauffage de l'eau. Water heating power. Potenza di riscaldamento del l'acqua. Potência de aquecimento. Wasserheizleistung (PW_{nom}/PW_{part})		13.4 kW
Eficiencia. Efficacité. Efficiency. Efficienza. Eficiência. Effizienz (η_{nom}/η_{part})		81 %
Eficiencia de calefacción estacional. Efficacité du chauffage saisonnier. Seasonal heating efficiency. Efficienza térmica stagionale. Eficiência de aquecimento sazonal. Saisonale Heizeffizienz (η_s)		71 %
Índice eficiencia energética. Indice d'efficacité énergétique. Energy efficiency index. Índice de eficiencia energética. Índice de eficiência energética. Energieeffizienzindex (EEI)		107
Clase. Classe. Class. Classe. Classe. Klasse		A+
Consumo de energía eléctrica. Consommation d'énergie électrique. Electrical energy consumption. Consumo di energia elettrica. Consumo de energia elétrica. Elektrischer Energieverbrauch (elmáx / elmin)		NPD
Consumo de energía modo espera. Consommation d'énergie en veille. Standby power consumption. Consumo energético in standby. Consumo de energia em espera. Standby-Stromverbrauch (elsb)		NPD

LACUNZA KALOR GROUP S.A.L

Pol. Ind. Ibarrea 5A

31800 Alsasua (Navarra) Spain

Tel.: (00 34) 948 56 35 11

Fax.: (00 34) 948 56 35 05

e-mail: comercial@lacunza.net

Website: www.lacunza.net

EDITION: 06

