

Itaca 80-100-120 eco C/V

Instruction Book

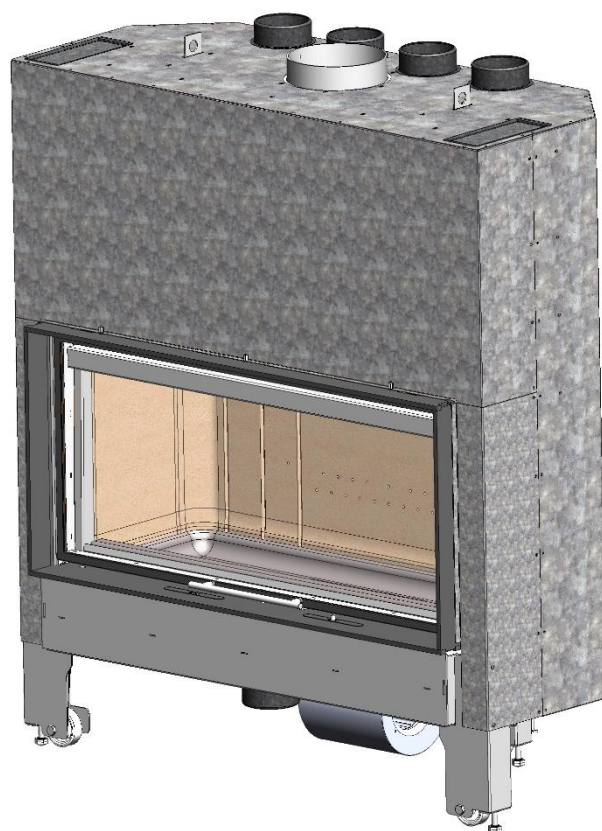



Lacunza congratulates you on your choice.
Certified under ISO 9001, Lacunza guarantees the quality of its appliances and undertakes to meet the needs of its customers.

Confident of the know-how afforded by more than 50 years' experience, Lacunza uses advanced technologies in the design and manufacture of its entire range of appliances. This document will help you install and use your appliance in optimum conditions for your comfort and safety.

CONTENTS

1. PRESENTATION OF THE APPLIANCE	3
1.1. General characteristics.....	3
2. INSTRUCTIONS FOR THE INSTALLER.....	8
2.1. Warning to installers.....	8
2.2. Room for installation.....	8
2.2.1. Ventilation of the room.....	8
2.2.2. Location of the appliance in the room.....	9
2.3. Installation of the appliance.....	9
2.3.1. Floor.....	9
2.3.2. Safety distances.....	9
2.3.3. Checks before lighting for the first time.....	9
2.3.4. Height adjustment and levelling the appliance.....	10
2.3.5. Casing.....	10
2.3.6. Connection to the flue.....	11
2.3.7. Piping air to other rooms.....	11
2.3.8. Piping air to the firebox.....	12
2.3.8.1. Combustion-air intake and hot-air output installation options.....	12
2.3.9. Exterior Frame. Removal and assembly.....	14
2.3.10. Fan and probe-air regulator connection (only for models C/V).....	15
2.4. Chimney flue.....	18
2.4.1. Type of flue.....	18
2.4.2. Chimney crown.....	19
3. INSTRUCTIONS OF USE.....	21
3.1. Fuel.....	21
3.2. Description of the parts of the appliance	22
3.2.1. Operating components.....	22
3.3. Lighting.....	23
3.4. Loading fuel.....	23
3.5. Operation	24
3.6. Removing ash	25
3.7. Deflectors.....	25
3.7.1. Itaca 80 eco.....	25



3.7.2. Itaca 100 and Itaca 120 eco.....	25
3.7.3. Removing the Itaca 80 eco deflectors.....	25
3.7.4. Removing the Itaca 100-120 eco deflectors.....	27
3.8. Opening the door.....	28
3.8.1. Opening using the guillotine system:.....	28
3.8.2. Door opening system to clean the glass.....	28
3.8.3. Door handle removal.....	30
3.9. Electrical system. Functioning.....	30
3.9.1. Forced convection. Turbine:.....	30
3.9.2. Automatic / manual air regulator operation:.....	31
4. MAINTENANCE AND IMPORTANT ADVICE.....	32
4.1. Maintenance of the appliance.....	32
4.1.1. Firebox.....	32
4.1.2. Inside the appliance.....	32
4.1.3. Flue socket.....	32
4.1.4. Firebox glass.....	32
4.1.5. Painted sheet-steel-cast-iron parts.....	32
4.1.6. Electrical system.....	32
4.1.7. Air intake registers.....	33
4.2. Maintenance of the chimney flue.....	33
4.3. Important advice.....	33
5. TROUBLESHOOTING.....	34
6. BASIC BREAKDOWNS.....	35
7. RECYCLING DE PRODUCT.....	40
8. DECLARATION OF PERFORMANCE.....	41
9. CE MARK.....	47

1. PRESENTATION OF THE APPLIANCE

For optimum operation of the appliance, we advise you to read this manual carefully before switching on the appliance for the first time. In case of problems or concerns, we urge you to contact your dealer, who will cooperate with you.

In order to improve the product, the manufacturer reserves the right to make changes without notice by updating this document.

This appliance is designed to burn wood in absolutely safe conditions.

WARNING: Faulty installation may have serious consequences.

Installation and all necessary regular maintenance operations must be performed by an authorized installer in full accordance with the specifications set out in the legislation applicable in each country and this instruction book.

1.1. General characteristics

	Unit	Itaca 80 eco	Itaca 100 eco	Itaca 120 eco	
Operating appliance	-	Intermittent	Intermittent	Intermittent	
Appliance classification	-	Type BE	Type BE	Type BE	
Preferred fuel	-	Wood logs (Humidity<25%)	Wood logs (Humidity<25%)	Wood logs (Humidity<25%)	
Indirect heating functionality	-	NO	NO	NO	
Values at Nominal Output	Nominal output to atmosphere (Direct) (P_{nom})	kW	12	13	14
	Efficiency at P_{nom} (η_{nom})	%	85.2	79.5	79.5
	CO emission at 13% O ₂ at P_{nom} (CO_{nom})	mg/m ³	1000	1000	1000
	NO _x emission at 13% O ₂ at P_{nom} (NO_{xnom})	mg/m ³	121	121	87
	OGC emission at 13% O ₂ at P_{nom} (OGC_{nom})	mg/m ³	39	66	66
	PM emission at 13% O ₂ at P_{nom} (PM_{nom})	mg/m ³	20	25	25
	Optimum flue draught at P_{nom} (p_{nom})	Pa	12	12	12
	Gas temperature of flue at P_{nom} (T_{nom})	°C	212	245	245
	Gas temperature on the flue socket flange at P_{nom}	°C	255	294	294
	Log load frequency at P_{nom}	h	1	1	1
	Gas mass flow at P_{nom}	g/s	9.1	13.9	13.9
	Wood consumption (beech) at P_{nom}	kg/h	3.4	4.2	4.2
	Chimney temperature class	-	T400	T400	T400
Dimensions of the firebox					
Width	mm	640	840	1040	
Depth	mm	360	360	360	
Useful height	mm	525	525	525	
Maximum length of the logs	cm	60	80	100	
Volume heated (45W/m ³) at P_{nom}	m ³	267	289	311	
Capacity of the ashpit	L	2.7	2.7	2.7	
Weight	kg	255	300	350	
Flue socket diameter (d_{out})	mm	200	200	200	
* Voltage (AC)	V	230	230	230	
* Frequency	Hz	50	50	50	
* Maximum electricity consumption (e_{lmax})	kW	0.275	0.275	0.275	
* Minimum electricity consumption (e_{lmin})	kW	0	0	0	



* Auxiliary electricity consumption in standby mode (e_{sB})	kW	0	0	0
Type of heat output/room temperature control	Single stage heat output, no room temperature control			
Energy efficiency class	-	A+	A	A
Energy efficiency index (EEI)	-	114 / 112*	105 / 104*	150 / 104*
Seasonal Energy Efficiency of space heating (η_s)	%	75 / 74*	70 / 68*	70 / 69*
* Models with fans (C/V)				

Note: The values indicated in the above table are based on tests performed in accordance with UNE-EN 13229, with logs with no more than 18% humidity and pressure conditions as indicated in each case.

Warning: this appliance is designed and prepared to work with the types of fuel, degree of humidity of the fuel, fuel loads, fuel load frequencies, flue draught and system of installation indicated in this Instruction Book. Failure to respect these conditions may lead to problems with the appliance (deterioration, shorter useful life, etc.) which are not covered by the Lacunza warranty.

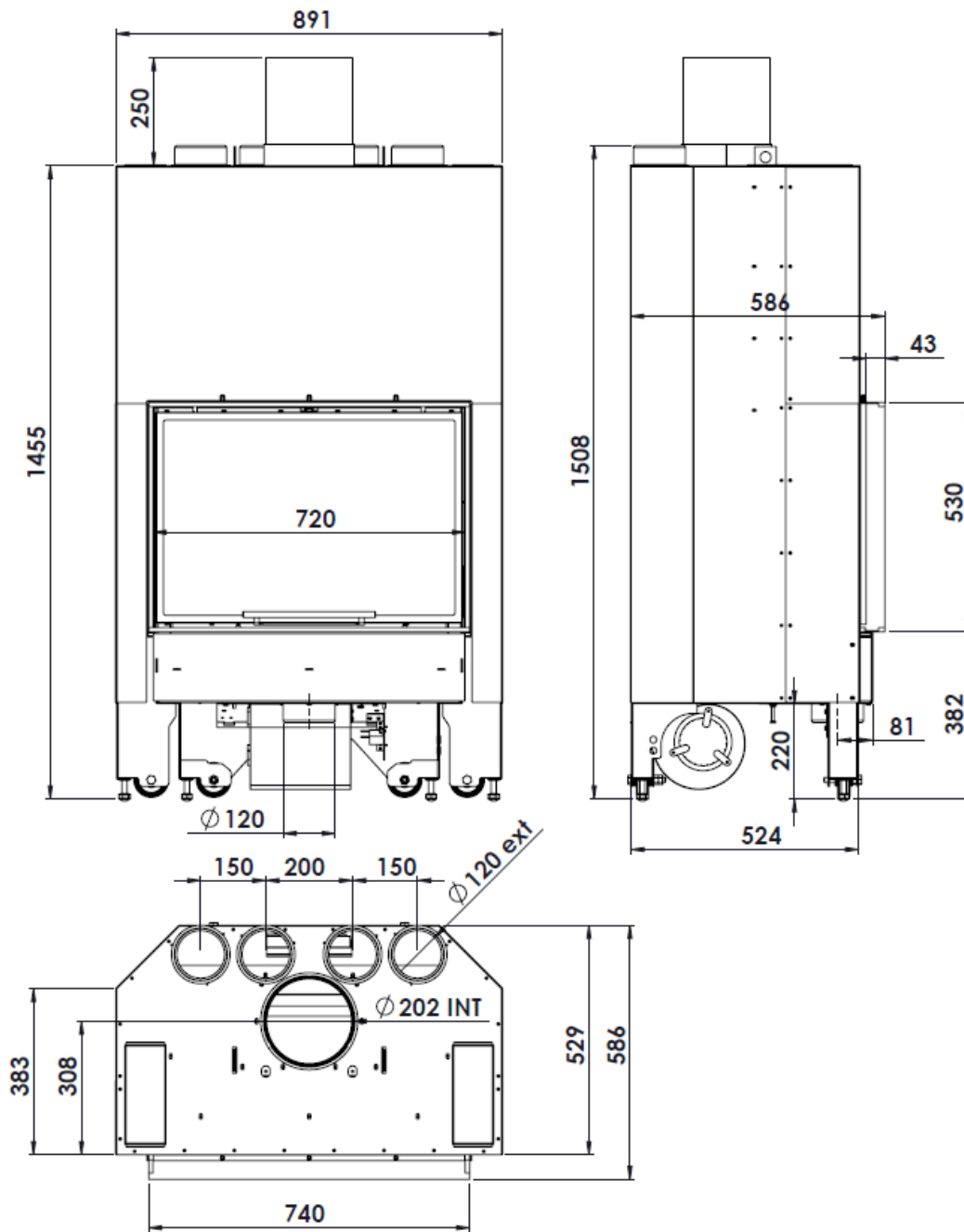

Figure No.1 - Dimensions of the Itaca 80 eco appliance in mm

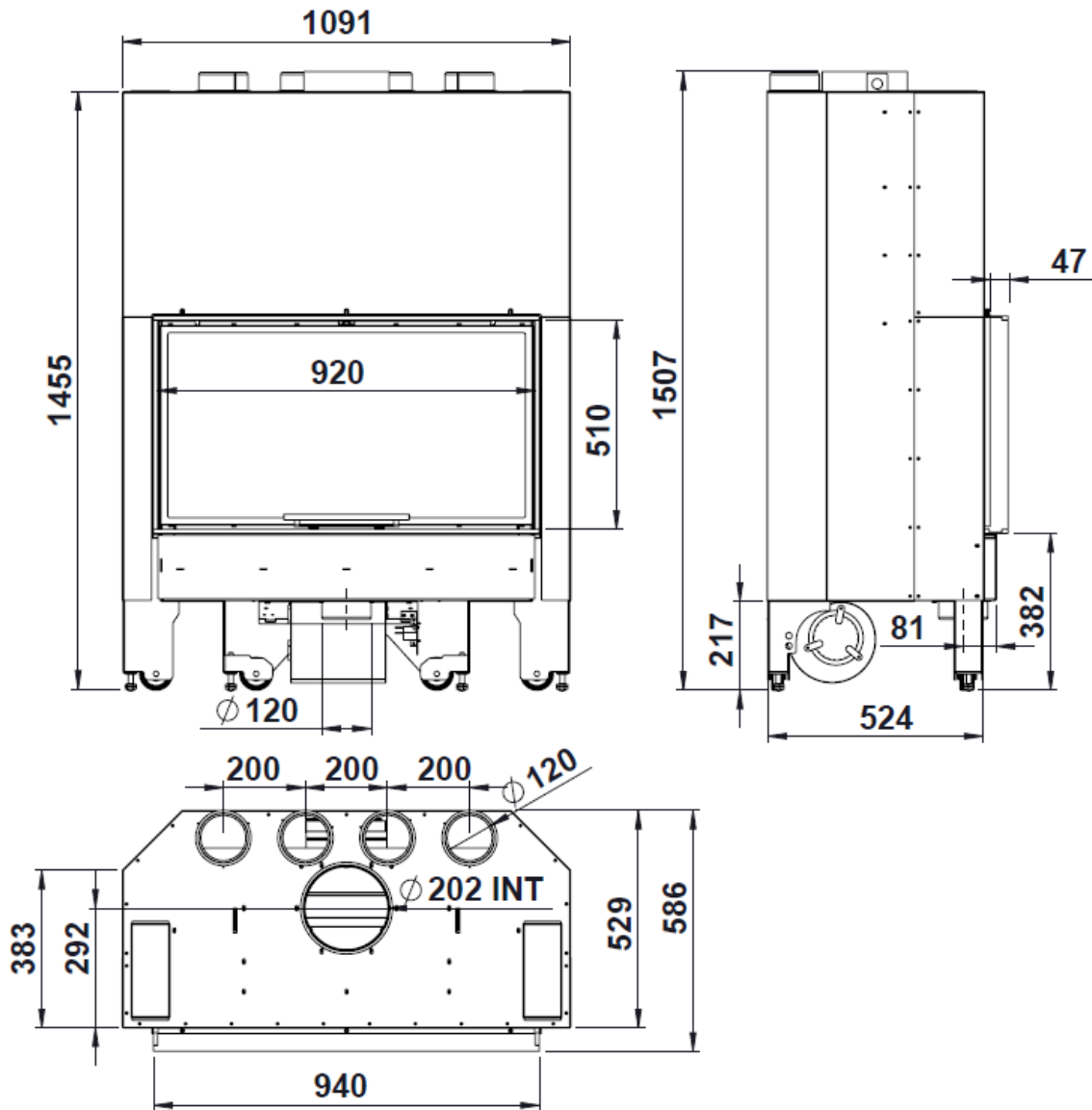

Figure No.2 - Dimensions of the Itaca 100 eco appliance in mm

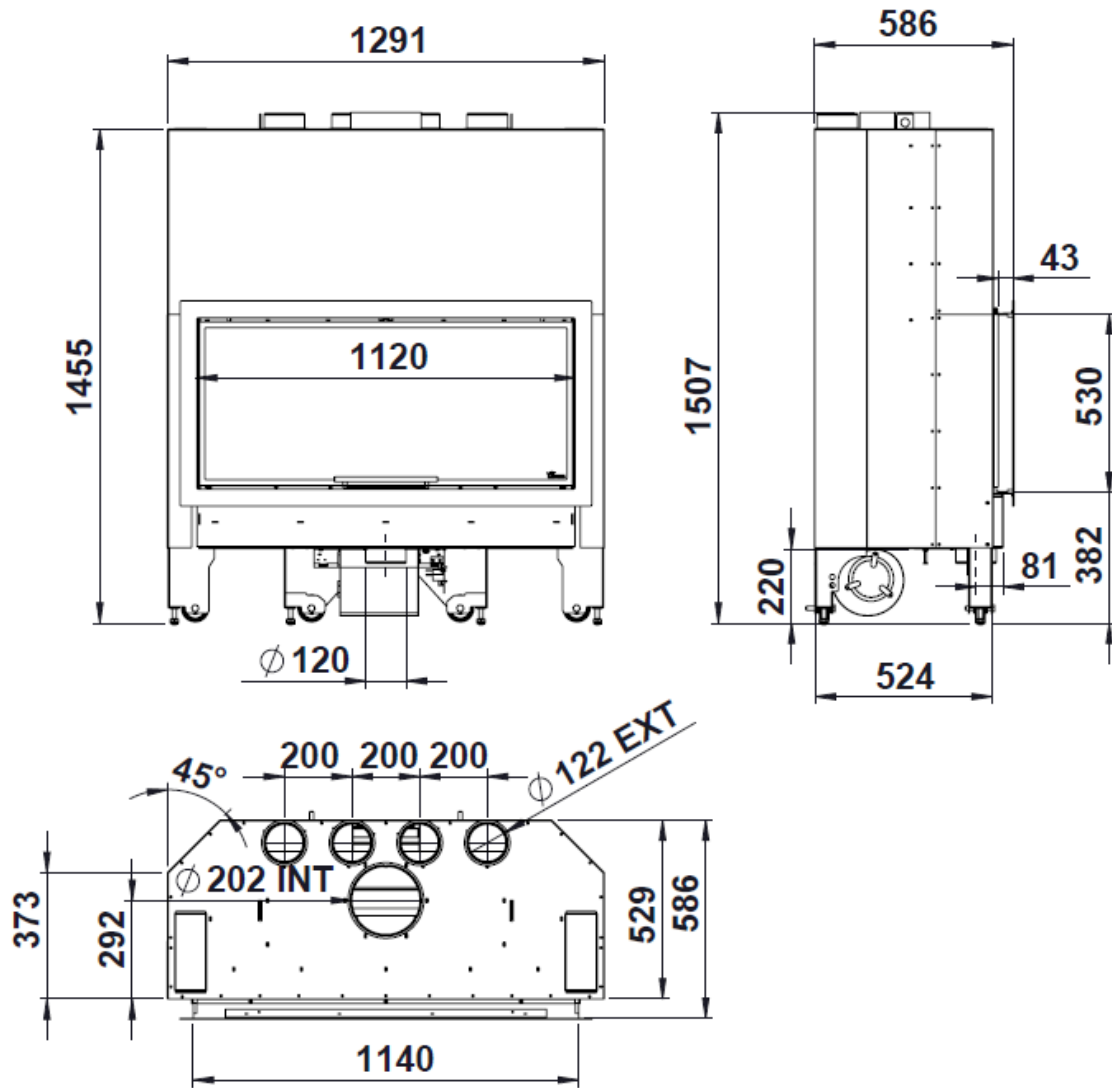

Figure No.3 - Dimensions of the Itaca 120 eco appliance in mm

2. INSTRUCTIONS FOR THE INSTALLER

2.1. Warning to installers

All local and national regulations, including all those referring to national and European standards, must be observed when installing the appliance.

Installation of the appliance must be performed by an authorised installer.

An incorrectly installed appliance may lead to serious incidents (fires, creation of harmful gases, deterioration of nearby fixtures, etc.).

Lacunza's liability is limited to the supply of the material and does not include installation of the appliance.

2.2. Room for installation

2.2.1. Ventilation of the room

The appliance needs to consume oxygen (air) in order to work properly. Ensure a suitable air supply in the room in which the appliance is fitted. This quantity of oxygen is additional to the oxygen that we need in order to breathe (air renewal).

In order to ensure the high quality of the air you breathe and to avoid potential accidents resulting from high concentrations of the gases produced by combustion (mainly carbon dioxide and carbon monoxide), it is absolutely crucial to ensure the suitable renewal of the air in the room in which the appliance is fitted.

the room must always have at least two permanent grilles or openings to the exterior in order to renew the air (one for intake and the other for extraction).

For the installation of its appliances, Lacunza recommends an additional section for these openings. One of these two grilles must be situated high up in the room (at less than 30 cm from the ceiling)

and the other one low down (at less than 30 cm from the floor). Both grilles must open outdoors in order to renew the air in the room with fresh air.

The air inlet grilles must be positioned so that they cannot be blocked or closed accidentally.

The minimum section that each of these grilles must have depends on the nominal output of the appliance in accordance with the following table:

Output of the appliance (kW)	Minimum additional section of each of the grilles (cm ²)
$P \leq 10\text{kW}$	70
$10 < P \leq 15$	90
$15 < P \leq 20$	120
$20 < P \leq 25$	150
$25 < P \leq 30$	180
$30 < P \leq 35$	210
$P > 35$	240

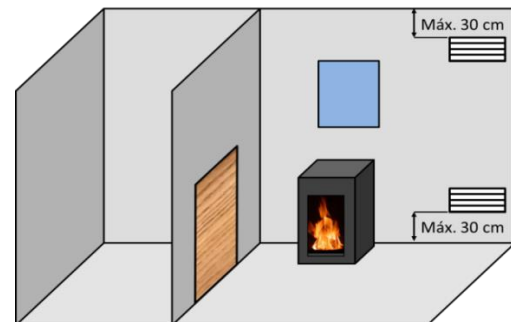

Figure No.4 - Guideline indications for ventilation grilles

In the case of appliances on which it is possible to pipe combustion air in from outdoors (appliances type BE, BF, CA, CM y CC), the specifications described in the Table above are not necessary.

The appliance must always be used with the door(s) closed.

In rooms equipped with Controlled Mechanical Ventilation, the system

extracts and renews the ambient air; in such cases, the room is at slightly low pressure and it is necessary to install a non-closable outside-air inlet with a section of at least 90 cm².

2.2.2. Location of the appliance in the room

Choose a location in the room which favours good hot-air distribution by convection and radiation.

The appliance comes with wheels to help move it into position. In order to move it, it is necessary to make sure that the support legs are raised by turning them with the aid of a spanner. Once in position, lower the legs until the appliance is at the desired height.

2.3. Installation of the appliance

2.3.1. Floor

Make sure that the base can withstand the total constructed weight of the appliance and its casing.

When the floor surface (base) is combustible, fit suitable insulation.

2.3.2. Safety distances

Be sure to respect the appliance installation distances from **combustible materials**. Looking at the appliance head-on:

ITACA 80 eco	Distance to combustible materials (mm)
From the right-hand side	200
From the left-hand side	200
From the rear	300
From the front	1000

ITACA 100-120 eco	Distance to combustible materials (mm)
From the right-hand side	400
From the left-hand side	400
From the rear	400
From the front	1600

Bear in mind that it may even be necessary to protect non-combustible material in order to prevent breakage, deformation, etc., as a result of overheating if the non-combustible material is not designed to withstand high temperatures.

2.3.3. Checks before lighting for the first time

- Make sure that the glass/es is/are not broken or damaged.
- Make sure that the flueway is not obstructed with packing or loose parts.
- Make sure that the airtight joints on the flue circuit are in perfect condition.
- Make sure that the doors close properly.
- Make sure that all moving parts are fitted in place.
- Check that the two deflectors are fitted properly; the lower deflector has four positions with which to open or close the flue to a greater or lesser extent. On the NON-BASIC version of Itaca, make sure that the flue damper flapper valve works properly. When the guillotine door is raised, the flapper rotates to allow for greater smoke evacuation to avoid smoke entering the room. When the door is closed, the flapper returns to its horizontal position, acting as a flue damper.
- Remove the bolts securing the counterweights before trying to close the guillotine door: when you remove ITACA fireplace models from their

packaging, you will see that the door is open at its highest position and cannot be lowered. This is because the counterweights are secured with M6 bolts on the 2 front legs at the bottom of the appliance so that they do not swing and damage the appliance during transportation. Do not try to move the door before removing the bolts that secure the counterweights

IMPORTANT: Remove the nut and bolt on each side of the appliance before lowering the guillotine door

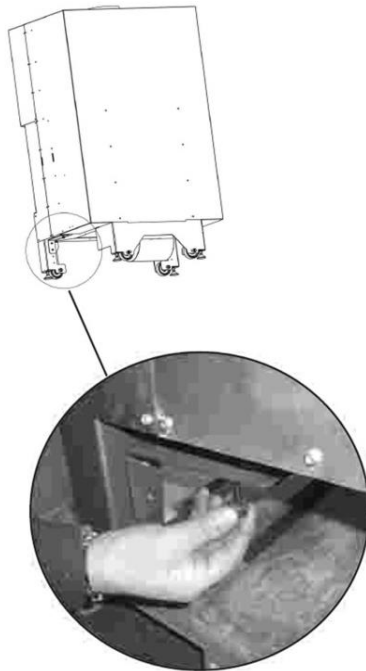

Figure No.5 - Access to remove the bolts securing the counterweights

2.3.4. Height adjustment and levelling the appliance

The appliance must be perfectly level, horizontally and vertically, both at the front and on the sides (use a spirit level).

The appliance has adjustable legs with which to adjust its height.

IMPORTANT! When it is level and before encasing the appliance, check that the guillotine door works properly; the door

risers and lowers smoothly and without any friction or noise other than that of correct operation of the guillotine system.

2.3.5. Casing

Make sure that the material around the appliance is not flammable or likely to deteriorate as a result of heat (wallpaper, carpet, plastic-based casing, Silestone, etc.).

The image below gives an example of how the appliance can be encased properly:

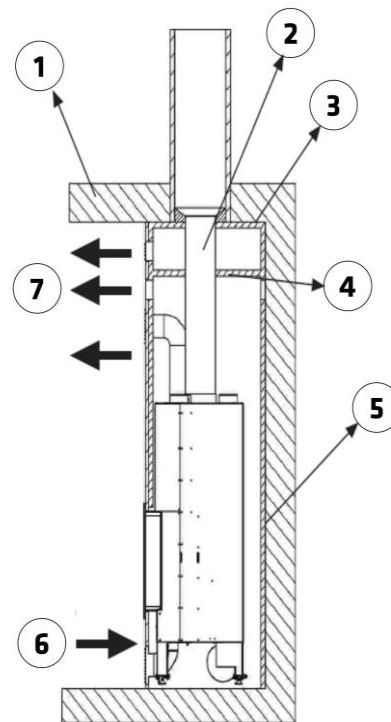

Figure No.6 - Interior diagram of the casing

Key to casing diagram:

- 1 Ceiling
- 2 Flue
- 3 Incombustible material (Inner hood insulation)
- 4 Insulating deflector made of incombustible material
- 5 Wall
- 6 Fresh-air inlet (1,000 cm²)
- 7 Hot-air outlet (1,000 cm²)

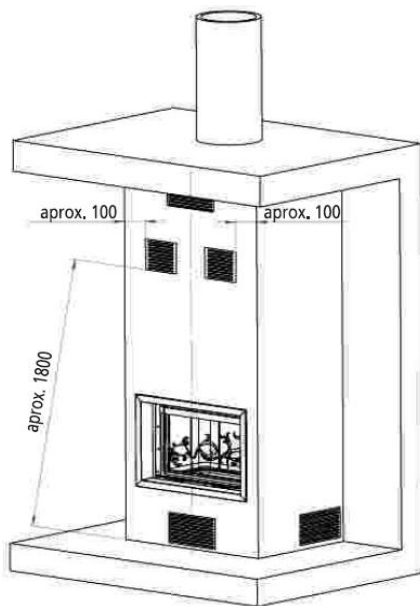

Figure No.7 - Exterior diagram of the casing

In order to enable suitable air circulation and correct operation, the casing must have a fresh-air inlet with a minimum section of $1,000\text{cm}^2$ beneath the level of the actual appliance and a hot-air outlet measuring at least $1,000\text{cm}^2$ above it (just before the insulating deflector inside the casing). These inlet and outlet sections must ensure air renewal in such a way as to avoid damage to parts inside the hood due to excess temperature.

This specification must be observed regardless of the type of installation chosen (with or without forced ventilation, combustion air from indoors or outdoors, directed hot-air outlets with or without pipes, etc.). A further hot-air ventilation grille is also recommended between the insulating deflector on the hood and the ceiling.

Warning: on appliances on which it is possible to pipe air to the firebox, the hood requires a further air inlet at the bottom, in addition to the $1,000\text{cm}^2$ inlet, if the air supply comes from the room in which the appliance is fitted.

On non-central-heating appliances (without back boiler), Lacunza does not

recommend enveloping the outside of appliances with insulation.

The installer must fit the necessary inspection accesses (trap doors, hatches, etc.) so that everything inside the hood that may need maintenance work, cleaning or replacement can be accessed at any time, e.g. counterweight system, hydraulic components, heating circuit safety components.

2.3.6. Connection to the flue

The appliance must be connected to the chimney flue using special piping designed to resist the products of combustion (e.g. stainless steel, enamelled steel, etc.).

To connect the flue to the socket flange, insert the piping inside the flange and seal the joint with fire sealant or fire cement to make it completely airtight.

The installer must ensure that the pipe connected to the appliance is well secured and there is no chance of it coming free from its housing (e.g. as a result of dilatation due to temperature, etc.).

2.3.7. Piping air to other rooms

It is possible to pipe some of the heat generated to other rooms in the house using the appliance. This does not mean that the appliance works more efficiently, but it does mean that the heat it creates is distributed better. For this purpose, in the top surface of the appliance there are 4 potential hot-air outlets with diameters of 120mm on the top shell of the appliance. Pipes can be fitted from these outlets to other rooms. If you intend to do this, bear the following points in mind.

- The air ducts must always be heat insulated and smooth inside (not corrugated).
- The pipes must always have an upward slant to facilitate movement by air density.

- On routes with a lot of load loss (a lot of retention), air movement can be forced along the ducts using a motor or fan, provided that it is designed to withstand such temperature conditions.

Bear in mind that air ducts mean that noise travels more easily from one room to another.

The following table shows the heat output of the air from the hot-air outlets with the appliance working at Nominal Heat Output:

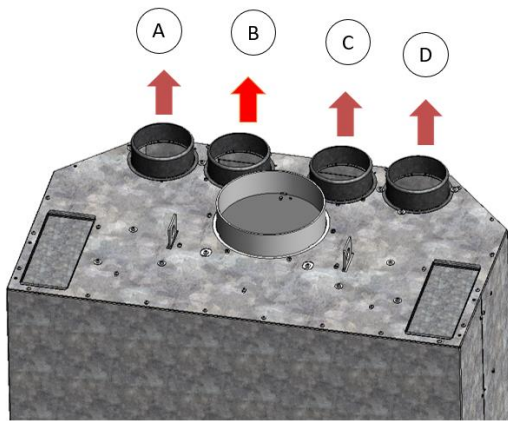

	Output Itaca 80 eco (kW)	Output Itaca 100 eco (kW)	Output Itaca 120 eco (kW)
A	2,5	2,7	2,7
B	2,5	2,7	2,7
C	2,4	2,6	2,6
D	2,1	2,3	2,3

Figure No.8 - Table showing heat output of the air leaving the appliance

Note: The values shown in the above table were measured at the appliance output point and based on tests performed at nominal heat output and maximum fan speed.

All hot-air ducts lose heat, meaning that the heat output obtained at the end of piping always depends on its design.

2.3.8. Piping air to the firebox

On this model, it is possible to pipe air to the appliance for combustion straight from outdoors. We recommend that, if possible, air be drawn from outdoors for combustion via a non-closable pipe with a diameter of 120mm leading to the nozzle on the bottom-front of the appliance. This is the best option because it means that draughts are not created in and oxygen is not consumed from the room in which the appliance is fitted. A further advantage is that there is no danger of downdraught which may hinder the correct updraught of the appliance when an extractor or mechanical ventilation appliance is used in the same room as the central-heating appliance or in another one alongside it.

If this is not possible, ensure that the appliance receives air for combustion via the relevant grille at the bottom of the hood (in addition to the hood ventilation grilles).

2.3.8.1. Combustion-air intake and hot-air output installation options

Different installation systems need to be borne in mind depending on the source of combustion air (air from outdoors or from inside the room in which the appliance is fitted) and the hot-air output system (air output by natural convection or by forced convection involving a fan) to ensure that ITACA eco appliances work properly. There now follows a description and image of each of these options:

Key to combustion-air intake and hot-air output installation option diagrams:

- 1 Hot-air output grille
- 2 Combustion-air intake grille
- 3 piping
- 4 Combustion-air intake nozzle
- 5 Combustion-air intake from outdoors

OPTION A: Combustion-air intake from inside the room and hot-air output by natural convection (without fan).

With this option, it is not necessary to lead the hot air along piping to the hot-air output grilles, as shown in the image, or from the combustion-air intake grille to the combustion-air nozzle that feeds combustion air to the firebox.

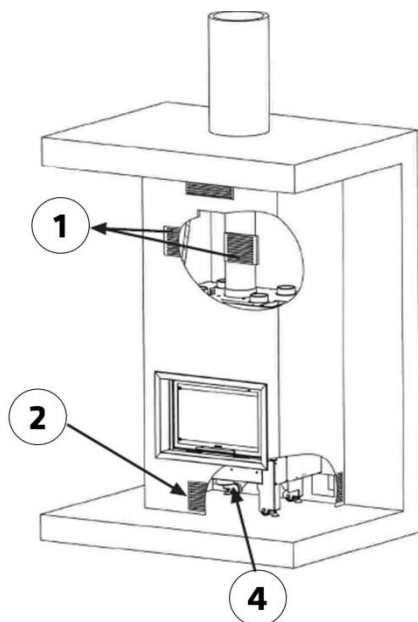

Figure No.9 - Image showing Option A

OPTION B: Combustion-air intake from inside the room and hot-air output by forced convection (with fan).

With this option, the hot air can be led along piping from the hot-air output nozzles on the appliance to the hot-air output grilles on the casing or to other rooms. The air flow required at any given time can also be regulated via the potentiometer on the fan. Up to 4 outputs

can be fitted (the nozzles not to be used should be capped). In such cases, the combustion-air intake must be led via piping from the grille on the outside of the casing to the combustion-air intake nozzle so that it does not interfere with the air drawn in by the fan.

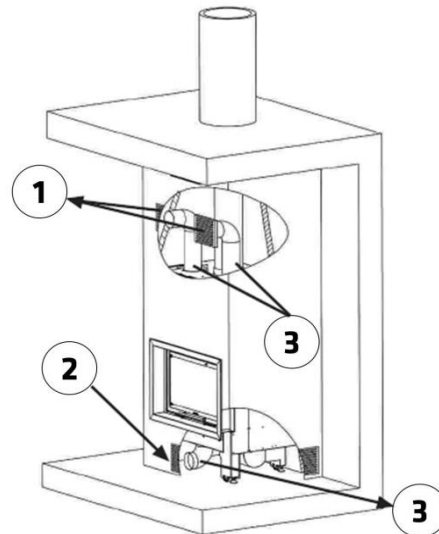

Figure No.10 - Image showing Option B

OPTION C: Combustion-air intake from outside the room and hot-air output by natural convection (without fan).

With this option, the combustion-air intake is led from outside the room in which the appliance is fitted (other room or outdoors) to the combustion-air intake nozzle via piping with a diameter of 120mm and it is not necessary to lead the hot air coming out of the nozzle on top of the appliance to the hot-air output grilles on the casing with piping.

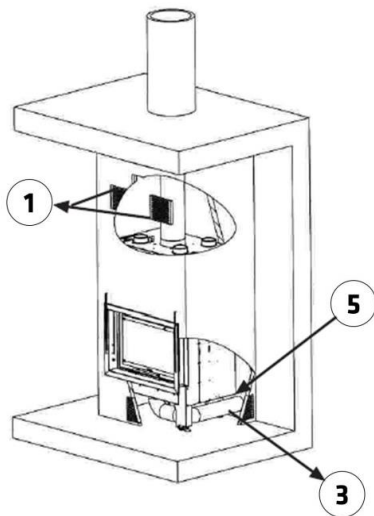

Figure No.11 - Image showing Option C

OPTION D: Combustion-air intake from outside the room and hot-air output by forced convection (with fan).

The installation system for this option is the same as that of the previous option, but also involves leading the hot-air output from the nozzles on top to the hot-air output grilles or to other adjoining rooms via piping with a diameter of 120mm. The nozzles on top of the appliance not to be used should be capped.

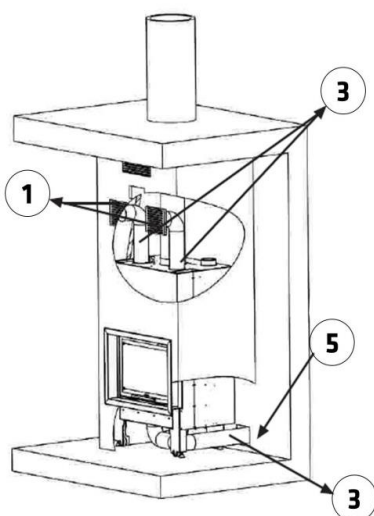

Figure No.12 - Image showing Option D

WARNING! When the appliance has a fan (C/V option), it is important that the shell is well ventilated through both the upper and lower grilles on the casing. Respect the minimum sections recommended for the grilles (larger grilles are no problem); otherwise, overheating problems may arise inside the shell and excess air temperatures may cause the fan to stop by triggering its overload safety system (in this case, due to excess temperature).

The combustion air intake (through the 120mm-diameter nozzle on the front-bottom of the appliance, which can be piped in from outdoors) **MUST** be fully independent from the fan air intake (through the grilles at the bottom of the sides of the casing, which draw air in from the room the appliance is fitted in) because they are separate air circuits.

WARNING: In all cases involving piping to lead hot air, the piping must be insulated and tend or slant upwards; never downwards. Bends, bottlenecks and horizontal sections more than 1m long should be avoided as much as possible. Bear in mind that the air circulating along the piping loses speed as it advances due to friction with the walls and the reduction in temperature. The ends of the piping used to lead air must be well sealed with fire sealant or fire cement. We recommend that the pipes used for forced convection do not exceed 4 metres in length.

2.3.9. Exterior Frame. Removal and assembly

If you need to remove the exterior frame from the appliance (casing, transportation, etc.), proceed as follows:

- Unscrew the 2 sliding knobs that control inlets 1 and 2 and remove them.

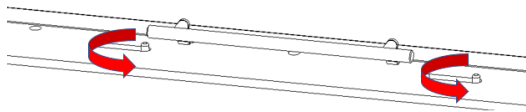

Figure No.13 - Unscrew the 2 sliding knobs for inlets 1 and 2

- Unscrew the 6 M6 screws that secure the sides of the frame.

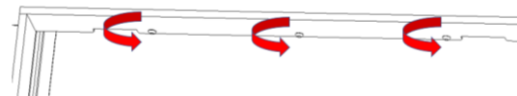
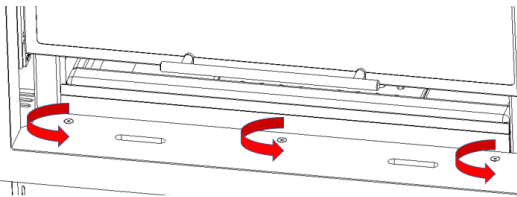

Figure No.14 - Unscrew the 6 screws, 3 lower and 3 upper that secure the exterior frame

- Remove the frame from its housing, being careful not to damage the enamel. First lift the frame to free the screws made visible by removing the sliding knobs and then pull it forwards.

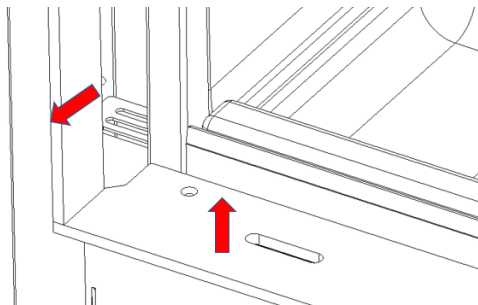

Figure No.15 - Removing the frame

- Perform the removal process in reverse order to refit the frame

2.3.10. Fan and probe-air regulator connection (only for models C/V)

ITACA eco c/v models (the models with fans) are prepared for connection on the air regulator supplied. The probe and the turbine are already in place.

The appliance has 2 hoses protruding from it:

- PROBE hose (SENSOR), 2 wires.
- Fan hose (M), 3 wires.

The two hoses are connected to the air regulator according to the connection diagram in the ELX AIR POWER auto instruction manual. **The electrical connections will be made by qualified personnel (see instructions in the manual)**

ATTENTION! The 3-wire power hoses for the power supply 230V is not supplied and must be connected by a person qualified to install it.

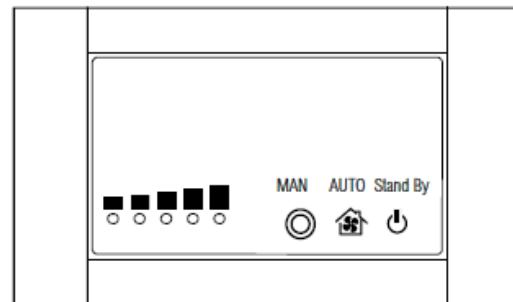

Figure No.16 - Controller of the air regulator ELX AIR POWER auto

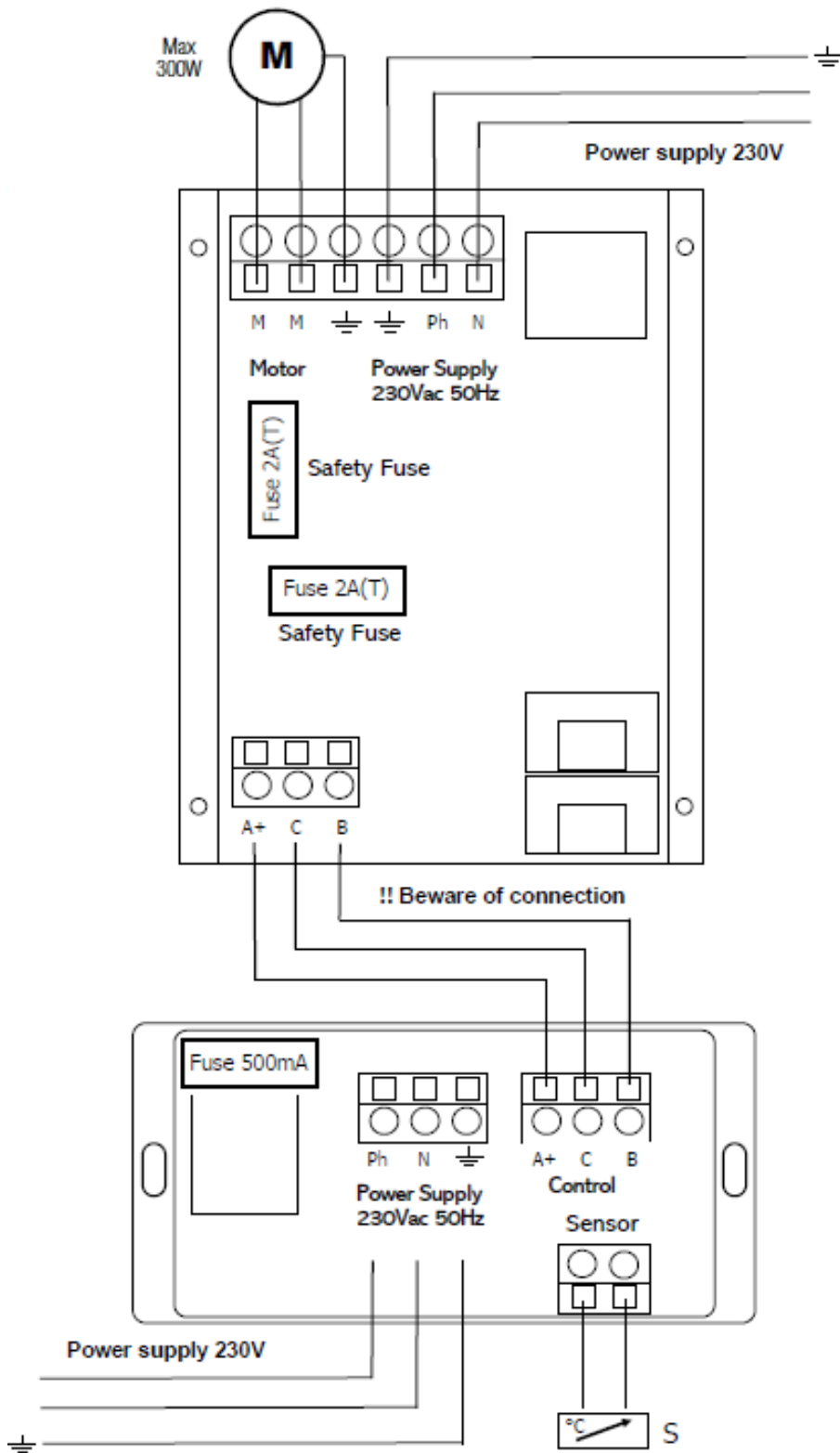

Figure No.17 - Connections to be made in the controller and the power module of the Itaca eco

ATTENTION! The power module, housed in a metal container of dimensions 150x107x64 mm with fixing fins, must be housed in a cold place, where the temperature never exceeds 50 °C. If it is placed inside the cladding, it should always go as close as possible to the vents of the cladding itself to ensure that it is in the coldest place possible.



Figure No.18 - ELX AIR POWER automatic air regulator power module.

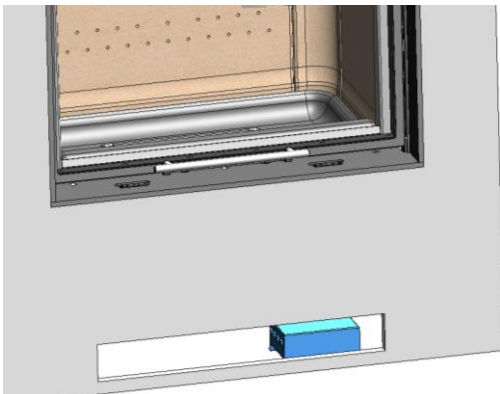

Figure No.19 - Positioning of the power module in front of the front ventilation grille

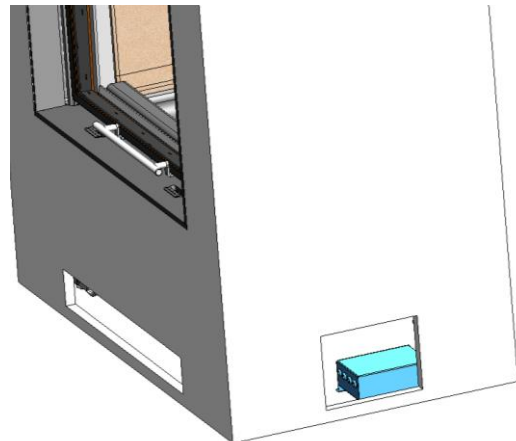

Figure No.20 - Positioning of the power module in front of the side ventilation grille

The temperature probe (SENSOR) is located at the rear of the appliance just at the outlet of the air driven by the turbine. There is access to it through the interior of the fireplace by removing the cast iron base and the screwed lower cover.

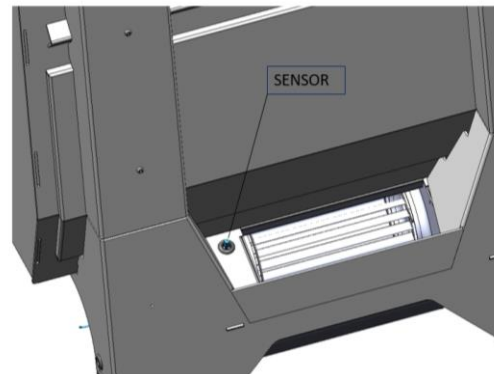
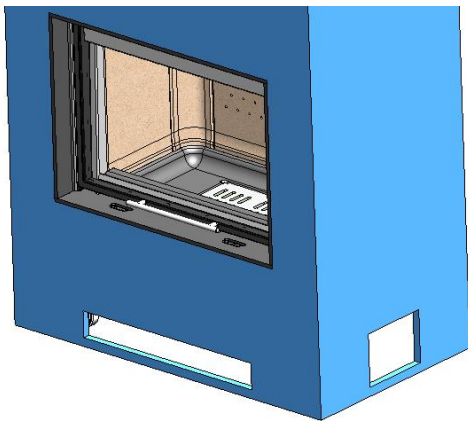

Figure No.21 - Position of the temperature probe (SENSOR) in the turbine air outlet

The air inlet section of the casing has an influence on the operation of the turbine in its automatic mode. The larger the air inlet section, the longer it will take for the turbine to start in automatic mode. On the contrary, the smaller the air inlet section, the less time it will take for the turbine to start up, but it will have a greater risk of reaching the temperature of

75°C, activating the security mode due to its lack of ventilation.

An air inlet section of at least 450 cm² is recommended, whether the grille is located on the front of the appliance, on the right side or on both sides.



WARNING: the operating temperature of the potentiometer supplied by Lacunza on ITACA C/V models (with fan) is from 0 to 40°C. Be particularly careful when choosing the place to fit it so that it cannot be damaged by temperatures of over 40°C. Fully insulate the potentiometer in order not to encounter this problem.

Read the potentiometer instruction manual.

2.4. Chimney flue

The chimney flue must comply with present standards on the installation of chimneys.

In rooms equipped with Controlled Mechanical Ventilation, the ventilation outlet must never be connected to the flue.

The appliance must always have its own chimney flue, never sharing a chimney flue with another appliance.

2.4.1. Type of flue

The flue must be made of special material designed to resist the products of

combustion (e.g. stainless steel, enamelled steel, etc.).

Non-central-heating appliances (without back boiler) require an insulated, double-sleeve flue only on those sections that run outdoors or through cold areas. Single piping can be used inside the building, the heat of the gases serving to heat rooms, insulating only those sections where excess temperature may cause damage.

If the chimney is constructed, then it is necessary to pipe and insulate it to ensure correct updraught.

The diameter of the pipe must be the same as the diameter of the flue socket on the appliance over its entire length in order to ensure correct operation.

The flue must prevent the entry of rainwater.

The flue must be clean and airtight over its entire length.

The flue must be at least 6m tall and the chimney cap must not hinder the free release of gases.

If the flue tends to suffer from downdraught, then it is necessary to fit an effective anti-downdraught cowl, a static cowl or a smoke extraction fan, or reshape the chimney.

Never make 90° bends, due to the great loss of draught they cause, and reduce 45° bends down to an absolute minimum. Each 45° bend is equivalent to a 0.5m reduction in flue length. Horizontal flue sections should not be installed because they cut updraught a great deal.

The appliance is designed to operate under controlled draught conditions. The appliance must operate at a chimney draught of between 12Pa and 15Pa. To ensure this draught, an automatic draught moderator must be installed in the flue. Uncontrolled draught operation can lead to

quick damage of the appliance, which will not be covered by the warranty.

The flue must not rest its weight on the appliance, as this could damage the worktop.

Bear in mind that high temperatures may be reached in the flue, meaning that it is essential that insulation be enhanced in sections in which combustible material is present (wooden beams, furniture, etc.). It may even be necessary to protect non-combustible material in order to prevent breakage, deformation, etc., as a result of overheating if the material is not designed to withstand high temperatures.

It must be possible to clean the entire flue, no sections being left inaccessible for cleaning purposes.

2.4.2. Chimney crown

The upper end of the chimney must clear the roof, the roof ridge or any obstacle located on the roof by at least 1m.

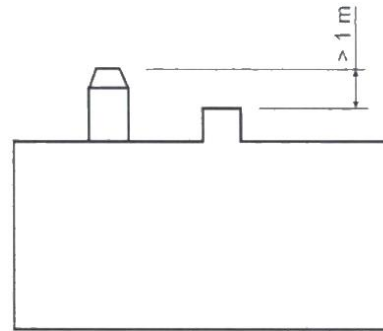
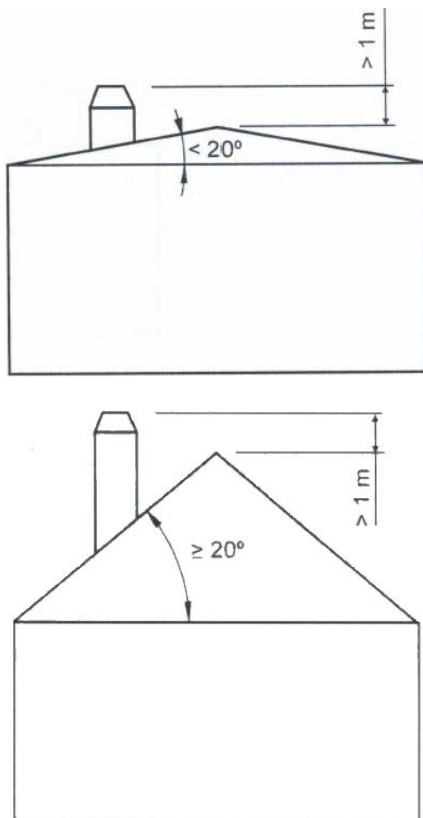

Figure No.22 - Distances between chimney crown and roof ridge

The chimney crown must clear the highest point of any neighbouring building or obstacle located within a 10m radius of the chimney outlet by more than 1m.

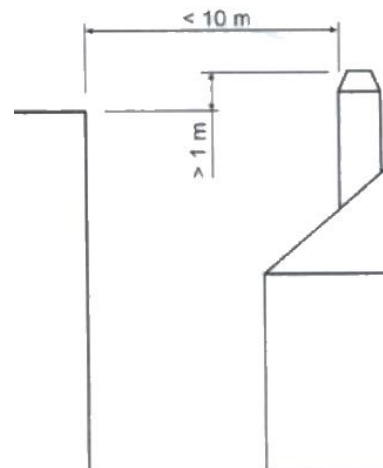

Figure No.23 - Distances between the chimney crown and objects within a 10m radius

The chimney crown must clear any neighbouring building or obstacle located within a radius of 10m to 20m from the chimney outlet.

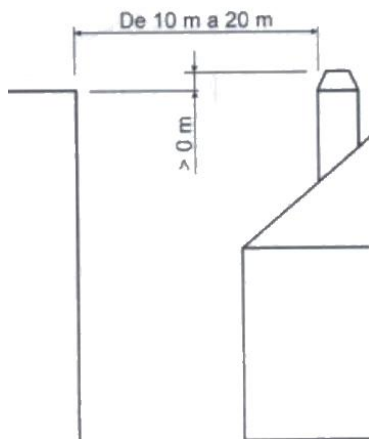

Figure No.24 - Distances between the chimney crown and objects within a radius of between 10 and 20m

3. INSTRUCTIONS OF USE

The manufacturer accepts no liability whatsoever for damage caused to parts as a result of the improper use of non-recommended fuels, modifications made to the appliance or how it is installed. **Only use original replacement parts.**

All local and national regulations, including those referring to national and European standards, must be observed when using the appliance.

Heat is diffused by radiation and convection via the front and exterior of the appliance.

3.1. Fuel

This appliance must not be used as an incinerator. Do not use non-recommended fuels.

- Use dry logs (max. 16% humidity), cut at least 2 years ago, clean of resin and stored in a sheltered, ventilated place.
- Use hard woods with high calorie values and good ember production.
- Large logs should be cut to useable lengths before being stored. The logs should have a maximum diameter of 150mm.
- Finely-chopped wood produces greater heat output, but also burns more quickly.

Optimum fuels:

- Beech.

Other fuels:

- Oak, chestnut, ash, maple, birch, elm, etc.
- Pine and eucalyptus logs are low density and produce very long flames, and may cause the parts of the appliance to wear out more quickly than normal.

- Resinous wood may mean that the appliance and the flue need to be cleaned more often.

Non-permitted fuels:

- All types of coal and liquid fuel.
- “Green wood”. Green or damp wood reduces the performance of the appliance and leads to soot and tar build-up on the inner walls of the flue, obstructing it.
- “Recovered wood”. The burning of treated woods (railway sleepers, telegraph posts, plywood, fibreboard, pallets, etc.) quickly blocks the system (soot and tar build-up), harms the environment (pollution, smells) and may lead to deformation of the firebox due to overheating.
- All materials which are not wood (plastic, spray cans, etc.).
- Never use gasoline, gasoline-type lamp fuel, paraffin, charcoal lighter fluid, ethyl alcohol or similar liquids to ignite or rekindle a fire in the equipment. Keep all such liquids away from the equipment while it is in use.

Green and reprocessed wood may cause chimney fires.

The graph below shows how the humidity of firewood affects its heat output:

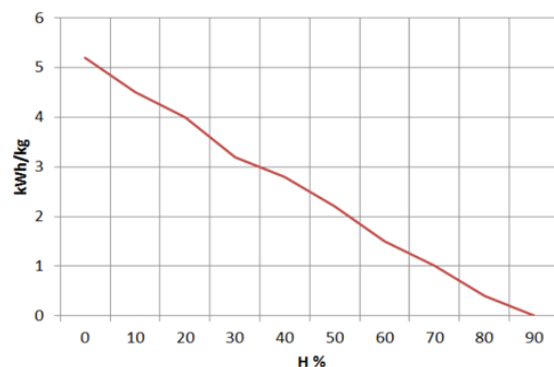

Figure No.25 - Relationship between firewood humidity and heat output.

3.2. Description of the parts of the appliance

3.2.1. Operating components

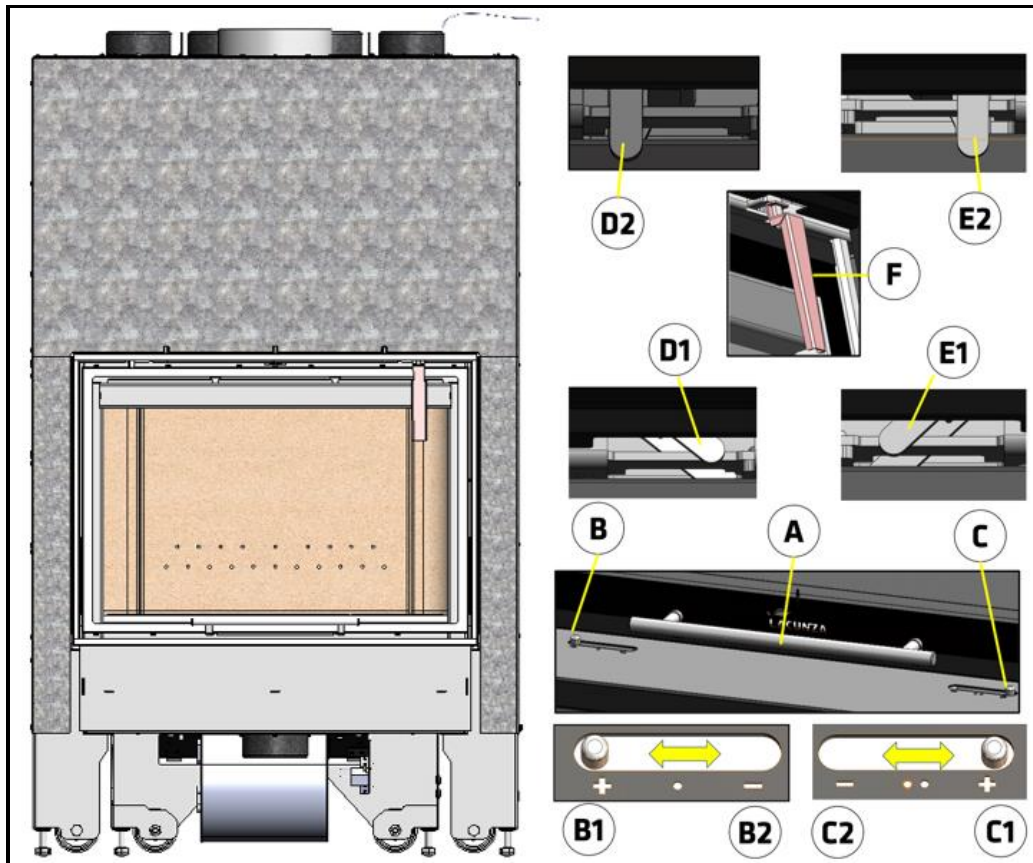

Figure No.26 - Operating components on the appliance

- A: Firebox door handle
- B: Primary air intake
 - B1 open (move towards the + symbol)
 - B2 closed (move towards the - symbol)
- C: Secondary air intake
 - C1 open (move towards the + symbol)
 - C2 closed (move towards the - symbol)
- D: LEFT-HAND catch on the door-opening system to clean the glass
 - D1 open (turn anti-clockwise)
 - D2 closed (turn clockwise until the catch is vertical)
- E: RIGHT-HAND catch on the door-opening system to clean the glass
 - E1 open (turn clockwise)
 - E2 closed (turn anti-clockwise until the catch is vertical)
- F: Tool to work the catches on the door opening system to clean the glass

3.3. Lighting

Use of the appliance in warm weather (warm days, early hours of the afternoon on sunny days) may lead to lighting and updraught problems.

Certain weather conditions, such as fog, ice, humidity entering the flue, etc., may hinder sufficient updraught in the flue and lead to suffocation.

Proceed as follows in order to light the appliance satisfactorily:

- Open the firebox door(s) and open all the firebox air-intake inlets to the full.
- Place paper or a firelighter and some wood chips in the firebox.
- Light the paper or firelighter.
- Leave the door slightly ajar, the width of two or three fingers, for about 15 minutes until the glass warms up.
- The first time the appliance is lit, the fire should be gentle to allow the parts of the appliance to dilate and dry.

Important: The first time it is lit up, the appliance may give off smoke and strange smells. This is not a cause for concern. Open an outdoor window to ventilate the room during the first few hours of operation.

If you notice water around the appliance, this is produced by the condensation of the moisture in the wood on lighting the fire. This condensation will no longer appear when the appliance has been lit three or four times and has adapted to its flue. If it does not disappear, then check the flue draught (length and diameter of the flue, flue insulation, airtightness) and the humidity of the wood used.

3.4. Loading fuel

In order to load firewood, open the firebox door gently, preventing the sudden entry of air to the firebox so that smoke does not enter the room that the appliance is installed in.

Perform this operation with the glove to prevent burns to the hands.

In the event of smoke plastering due to insufficient draft in the installation, proceed as follows:

1- Do not raise the door to the top. The less the door is raised when loading, the less smoke plaster will be produced.

2- In the Itaca 80 eco, change the position of the second deflector as shown in the image:

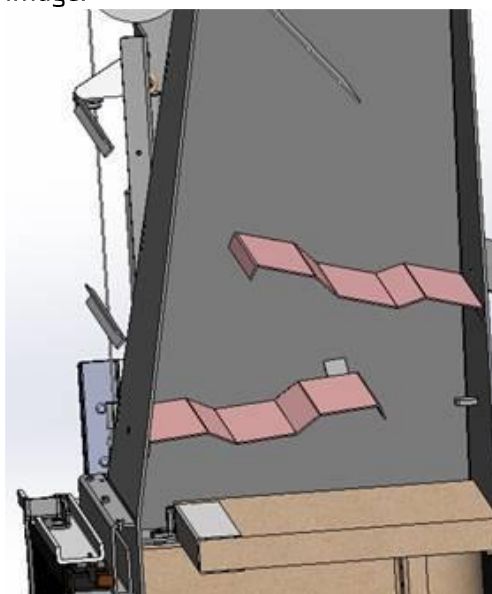

Figure No.27 - Current position of deflectors

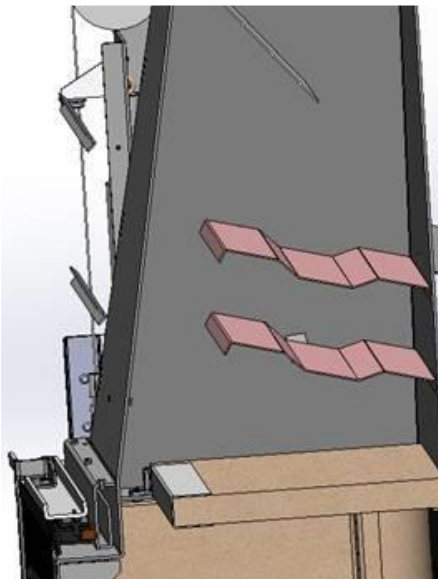

Figure No.28 - Changing the position of the second deflector to avoid plaster

The maximum height of the load shall be approximately one third of the height of the firebox.

The minimum interval between loads for nominal heat output is 60 minutes.

Always load with the nominal amount (see table in section 1.1).

For minimum burning (e.g. at night), use thicker logs.

When the firebox is loaded, close the door.

Be careful when placing logs in the firebox on appliances with vermiculite interiors. Vermiculite is a fragile material and may crack if knocked. The use of wood with non-recommended humidity levels will quickly damage the vermiculite parts.

3.5. Operation

The appliance should be operated with the door closed.

For safety reasons, never close all the appliance's combustion-air intakes.

Primary-air intake

By opening this inlet, air enters the firebox via the firebox grille.

Secondary-air intake

By opening this inlet, air enters the firebox via the top of the firebox door.

IMPORTANT: Keeping the secondary-air intake open helps keep the door glass cleaner for longer.

Double-combustion air intake

By opening this inlet, air enters the combustion flame, making for more efficient and less polluting combustion because post-combustion takes place, burning the particles which were not burned in the first combustion. This increases the performance of the appliance and reduces emissions.

On Itaca models, the double-combustion air intake is the same as the secondary-air intake (both air intakes are controlled through the same inlet at the same time).

IMPORTANT: The appliance is exposed to extreme changes in temperature and may, as a result, make noises when in operation. These noises are a natural result of expansion/contraction of the parts which make up the appliance. Do not be alarmed by noises of this kind.

In order to obtain maximum output, open all the air intakes to the firebox and in order to obtain minimum output, tend towards closing them. If you wish the fire to liven up quickly, temporarily raise the guillotine door one or two centimetres to make oxygen enter the firebox quickly. For normal use, we recommend you close the Primary Intake and leave the Secondary and Double Combustion Intakes open.

In class B or BE appliances (without combustion air ducting from the street), when the appliance is not in use, the appliance-flue duct assembly may represent a heat leakage route to the street. When the appliance is not in use, it is advisable to leave the air inlet registers to the combustion chamber closed to minimise these energy losses.

3.6. Removing ash

Following sustained use of the appliance, it is necessary to remove the ash from the firebox. Remove the ashpit box when cold or using something to prevent yourself from getting burned (glove).

Never throw hot embers into the rubbish.

Access the ashpit by opening the door on the appliance.

We access the ashpit by lifting the grill.

3.7. Deflectors.

3.7.1. Itaca 80 eco

The appliance has 4 deflectors. The upper one is fixed, whilst the other three can be dismantled.

You can see how they are fitted in the following pictures.

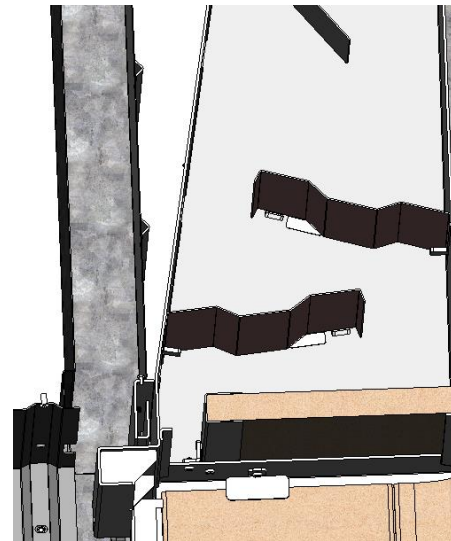
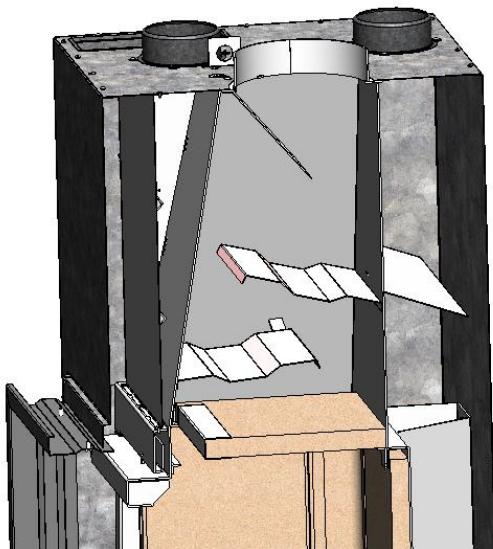

Figure No.29 - Section view with Itaca 80 eco deflectors fitted

3.7.2. Itaca 100 and Itaca 120 eco

The appliance has 2 deflectors. Both are removable.

You can see how they are fitted and regulated in the following pictures.

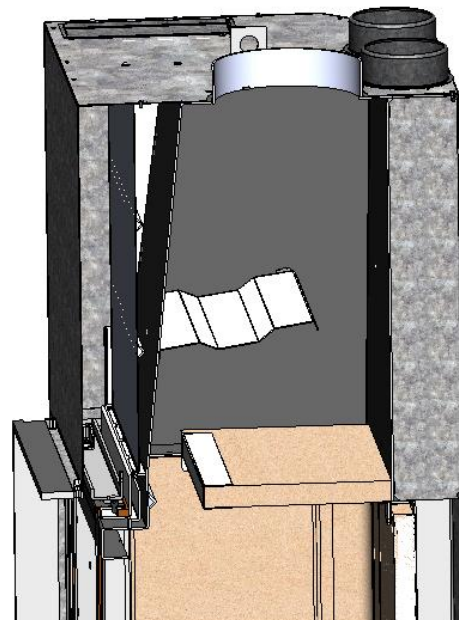

Figure No.30 - Itaca 100-120 eco section view with the 2 deflectors fitted

3.7.3. Removing the Itaca 80 eco deflectors

First remove the lower deflector by lifting it until it is clear of the tabs that

keep it in position. Then tilt one side downwards, lower and pull out.

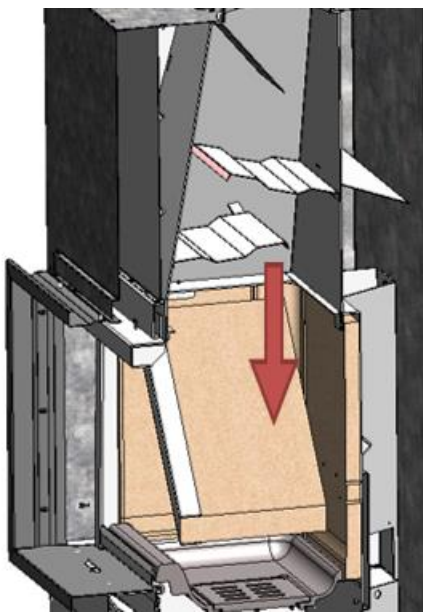
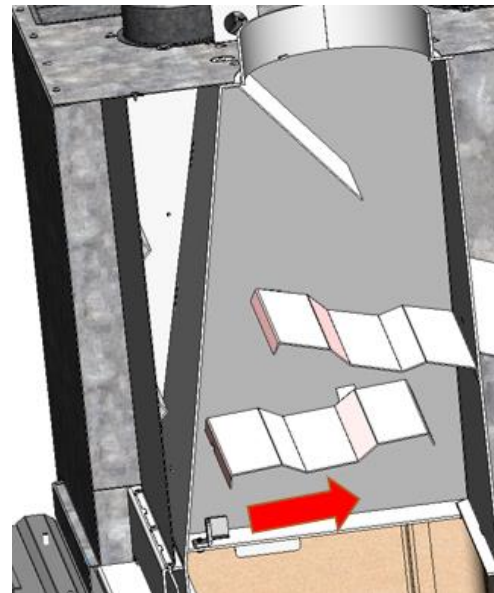
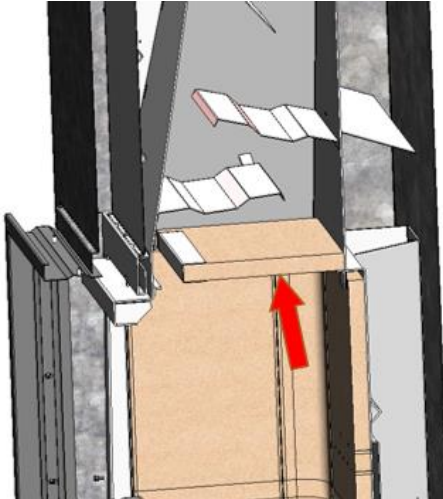

Figure No.31 - Dismantling the lower Itaca 80 eco deflector

Figure No.32 - Removing the middle deflector on the Itaca

Soot falling from the flue may build up on the deflector.

Then remove the second deflector by drawing it at the rear and allowing it to drop forwards.

Then remove the second deflector by drawing it forwards and allowing it to drop at the rear.

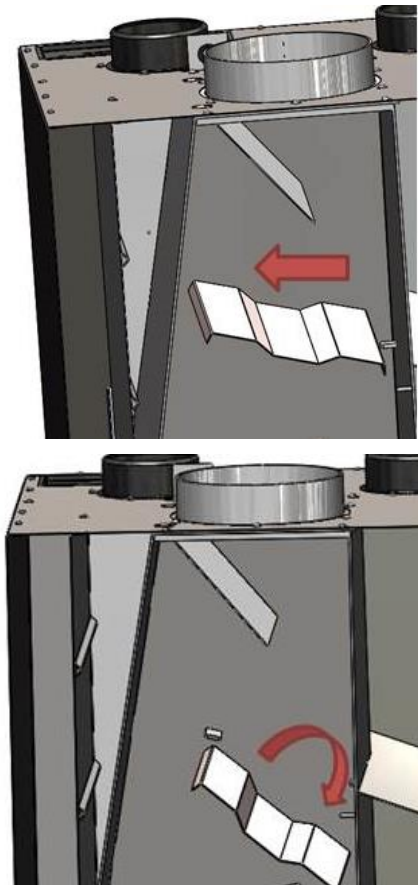

Figure No.33 - Removing the upper deflector on the Itaca 80

3.7.4. Removing the Itaca 100-120 eco deflectors

First remove the lower deflector by lifting it until it is clear of the tabs that keep it in position. Then tilt one side downwards, lower and pull out.

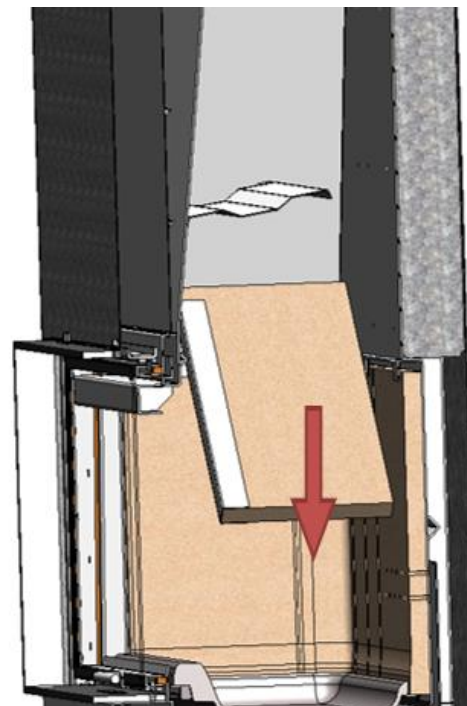
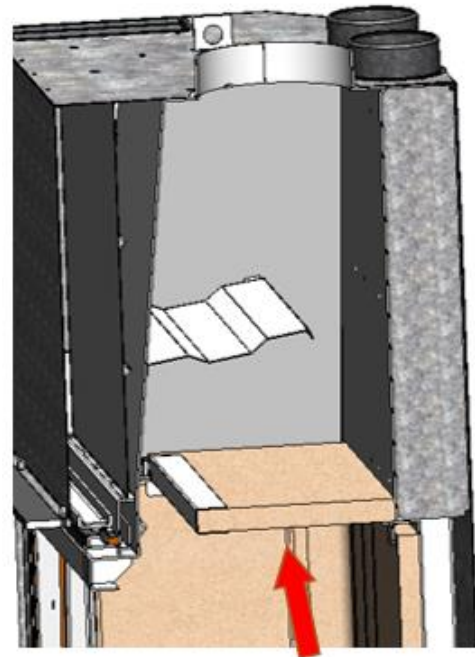

Figure No.34 - Dismantling the lower Itaca 100 y 120 eco deflector

Soot falling from the flue may build up on the deflector.

Then remove the second deflector by drawing it towards the rear and allowing it to drop forwards.

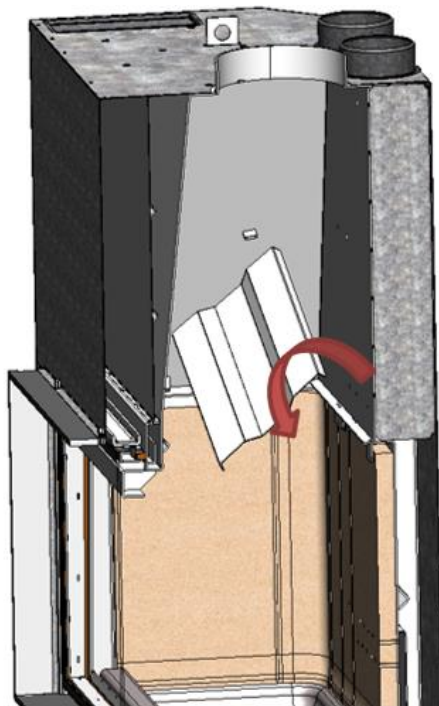
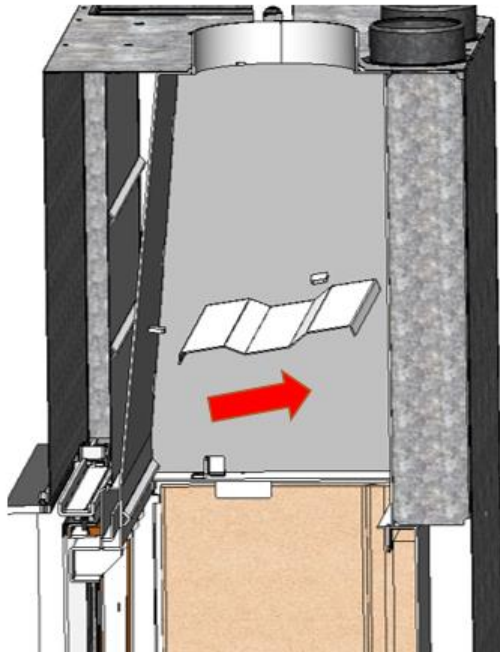

Figure No.35 - Removing the second deflector on the Itaca 100-120 eco

Soot falling from the flue may build up on the deflector.

3.8. Opening the door

The door can be opened in 2 ways:

3.8.1. Opening using the guillotine system:

This system, in which the door opens vertically, is the usual way to open and close the firebox in order to load and rearrange the firewood when the appliance is in normal use. Use the glove supplied in order to move the door using the handle in order to prevent possible burns to the hands. When you open the door, apply slight upward pressure to free the sealing cord from the front. When you have lifted the door a couple of centimetres, you should notice that it moves more freely than at first. To close the door, apply slight downward pressure when it is at its lowest position so that the cord completely seals the firebox from the outside.



Figure No.36 - Opening using guillotine system

3.8.2. Door opening system to clean the glass

This opening system should only be used when the appliance is cold (when there is no fire in the firebox) in order to clean the inside of the door glass. Using this system, the door is lowered from the top on its bottom hinges until it is practically horizontal. In order to open the door from the top, proceed as follows:

- With the door closed, insert the tool supplied by Lacunza in the catch on the top left of the door. Insert it all the way until it reaches its limit.

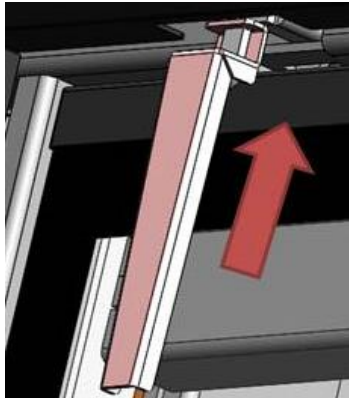

Figure No.37 - Insert the tool in the catch to open the door to clean the glass

- Then use the tool to turn the left-hand catch anti-clockwise until it reaches its limit.

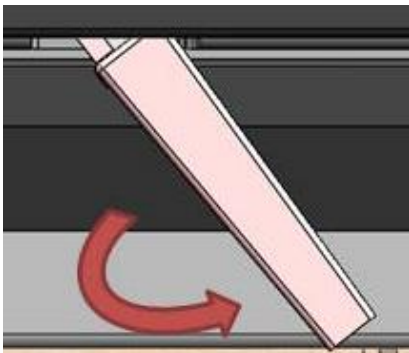

Figure No.38 - Turn the catch anti-clockwise

- Remove the tool from the left-hand catch and use it to perform the same operation on the right-hand catch, inserting it in the same way.
- Then turn the catch clockwise, as shown in the image, until it reaches its limit.

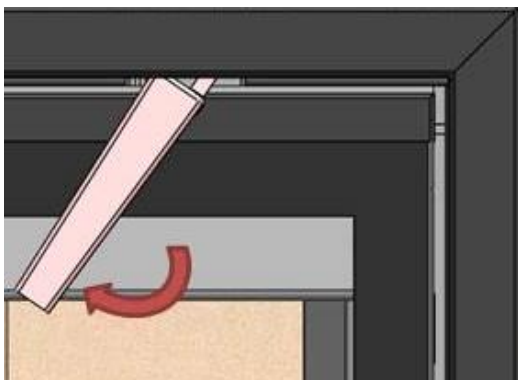

Figure No.39 - Turn the catch clockwise

When the catches are in position, as previously described, the door is free from the frame and can be lowered on its bottom hinges by pulling from the top.

WARNING! When the door is free from its catches and you start to lower it, be sure to support it with both hands (one on the handle at the bottom and the other at the top). As the door lowers, you will notice that it tends to rise due to inertia. Lower the door slowly so that it does not rise suddenly at the end of the lowering process. When the door has been fully lowered, make sure that the handle does not come into contact with the lower surface of the outer frame so as not to damage the enamel. Do this by lifting the door vertically a couple of centimetres above the base of the outer frame.

This is the entire door lowering sequence once it has been freed from its catches:



Figure No.40 - Hold the handle with one hand and pull the door open with the other.



Figure No.41 - Hold the door firmly with both hands as you lower it



Figure No.42 - Half lowered



Figure No.43 - Door fully lowered



Figure No.44 - Do not rest the door handle on the lower surface of the outer frame so as not to damage the enamel or paint

NOTE: When you have cleaned the door glass and want to return it to guillotine-opening mode, perform the same process in reverse order. When you turn the catches at the top to secure the door, you may find them somewhat hard to move. This is due to the pressure of the ceramic sealing cord against the front. In order to avoid this pressure, which makes it hard to move the catches to secure the door, you can lift the door vertically 2 or 3cm with the tool inserted in the catch and then turn

it. With the door at this higher position, the cord does not exert pressure on the front and it is easier to turn the catch to its limit position.

3.8.3. Door handle removal

The Itaca eco models have the possibility of using the door handle as a “cold hand”, that is, it can be removed from its housing after closing the door and reinserted to open it. To use the handle as a cold hand, you have to loosen the 4 screws that hold it to the door.

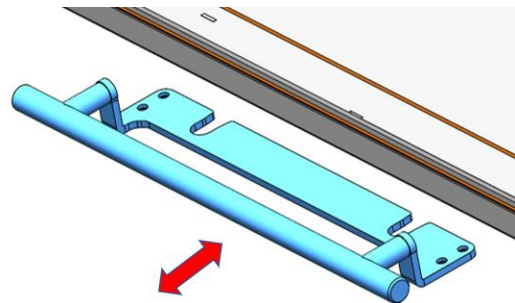
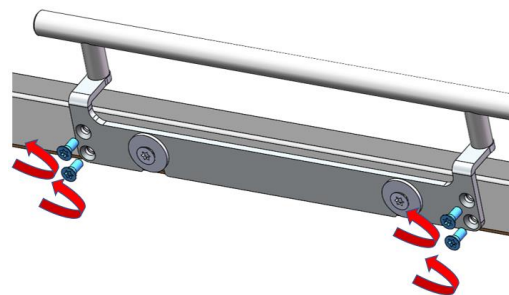

Figure No.45 - Screw removal and use as a cold handle handle

3.9. Electrical system. Functioning.

3.9.1. Forced convection. Turbine:

Itaca eco C/V models have a turbine for the forced convection of the hot air generated around the appliance inside the shell. This air can be piped to other rooms.

IMPORTANT: This appliance is not covered by our warranty unless directly connected to the mains electricity supply in accordance with the conditions described in the relevant section in 1.1.

Description:

Itaca eco appliances with the C/V option (forced ventilation with turbine) come with the following parts:







Parts and characteristics:

- **Turbine:**
 - Maximum input power: 275/285 W, 230V, 50/60Hz.
 - Speed (r.p.m.): 1250
 - Air flow (m³/h): 820/910
- **Probe:** probe supplied and an NTC10K with co-molded cable 2000mm.
- **Air regulator Automatic/manual ELX AIR POWER Auto:** see technical data in the manual supplied

Potentiometer operation:

By means of its rotating lever, the potentiometer controls the flow of hot-air output from the appliance in two ways:

3.9.2. Automatic / manual air regulator operation:

- **Operation:** when powered, the device shows the Stand-by light  point on. The controller is equipped with an automatic function  and a manual function . It is activated by pressing the  key, thus switching to automatic mode. To switch  to manual mode, press .
- **Automatic function:**

In this function the motor speed is given and displayed in the Led ramp by the temperature present in the generator at the point where the probe (S) is positioned. Starting at minimum speed is determined by a temperature above 40°C, increasing proportionally in the five speeds until the maximum speed is reached (Generator temperature above 60°C). Engine shutdown occurs when the given generator temperature drops below 30°C.

- **Manual function**

In manual key , the engine can be started even when the generator is cold, by selecting the desired speed of the air in the room with the key.

- **Safety function**

A safety start occurs at maximum power when a temperature above 75°C is present on the probe (S) even with the device off. The regulator is activated at the maximum dissipated speed, the excess temperature passes to automatic operation. Security is activated if the device is turned off.

- **Remote control**

The remote control replicates the functions present on the regulator itself.

- **Probe malfunction**

In the event of a probe malfunction, the device allows the motor to operate in Manual mode, this anomaly is signaled by the flashing  LED; replace the probe with the device off and disconnected from the mains.

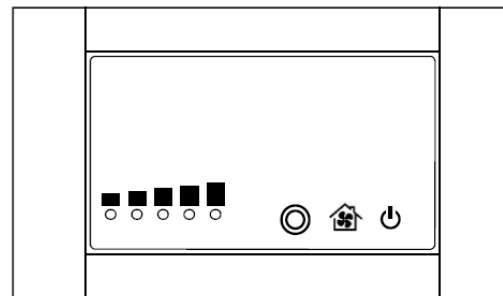

Figure No.46 - Itaca air regulator automatic/manual display

For more information, see the ELX AIR POWER air regulator instruction manual.

4. MAINTENANCE AND IMPORTANT ADVICE

4.1. Maintenance of the appliance

The appliance, the flue connector piping and the flue must be cleaned regularly, particularly following long periods without use.

4.1.1. Firebox

Clean the firebox area of ash, etc.

4.1.2. Inside the appliance

The inside of the firebox can also be accessed from the bottom by extracting-pushing up the cast-iron grille and removing the ashpit. Clean the area of ash through the hollow left after removal (use a vacuum cleaner if necessary). The cast-iron base can also be extracted if necessary.

Clean the firebox area of ash. Clean the deflectors, where soot may build up.

4.1.3. Flue socket

The flue socket area must be kept clean at all times for the appliance to work properly.

It must be cleaned as often as required. How often it is cleaned depends on how much the appliance is used and the type of fuel employed.

4.1.4. Firebox glass

To keep the glass as clean as possible for as long as possible, the secondary air register should be kept open. However, over the hours of use, the glass may become dirty. To clean it, we will use specific degreasing products or dry cleaning products for this task.

The cleaning should be carried out with the glass cold and taking care not to apply the glass cleaner directly on the glass as, if it comes into contact with the door's closing cord, it may deteriorate. Put the cleaning product on the cloth.

Attention, never let the product drip into the lower part of the glass. The accumulation of the cleaning product, with soot or ash residues, can damage the screen printing on the glass.

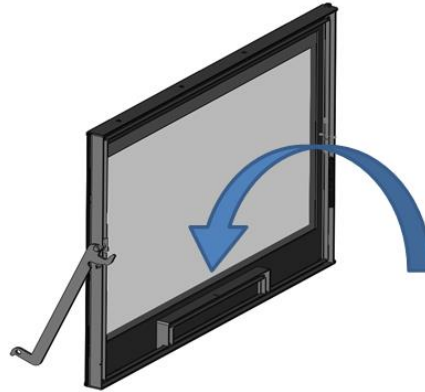

Note: If we use the appliance in draught conditions higher than 15Pa or burn more wood (per hour) than those indicated in table 1.1, we will subject the appliance to working conditions higher than those designed for it. This can lead to aggressive fouling of the glass (white halo), which cannot be cleaned by the traditional method.

Caution, the vitro ceramic glass is prepared to support 700°C. Never let burning woods or combustion flame beating against the glass for prolonged periods of time. In this case, the glass would be submit to temperatures above 750°C, this could change the internal structure of the glass and make it opaque (irreversible phenomenon).

4.1.5. Painted sheet-steel-cast-iron parts.

These parts should be cleaned with a brush or dry cloth. Do not dampen the parts: the steel could rust and the paint could blister and chip. Be particularly careful when cleaning the glass: the liquids used must not dampen the painted steel.

4.1.6. Electrical system

The electrical system should be cleaned-vacuumed regularly (depending on the installation and use), so as to avoid the accumulation of ash, lint and other

remains that may generate strange noises and/or deteriorate the ventilators and electrical system. Disconnect the electrical network system to perform this task.

Access to the turbine will be through the interior of the fireplace, removing the cast iron base and the lower cover.

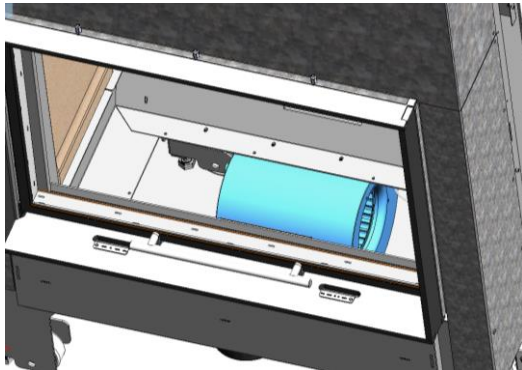

Figure No.47 - Access to the turbine through the interior of the fireplace

4.1.7. Air intake registers

In the air intake for combustion registers, remains of ash, sawdust, cleaning fluids, etc. may accumulate, which restrict or hinder its movement. In these cases, they should be released and cleaned. To access them, the outer frame would have to be previously removed.

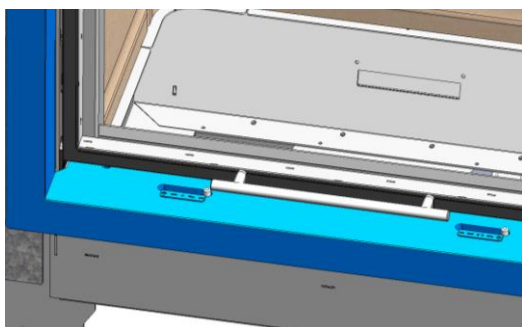

Figure No.48 - External frame

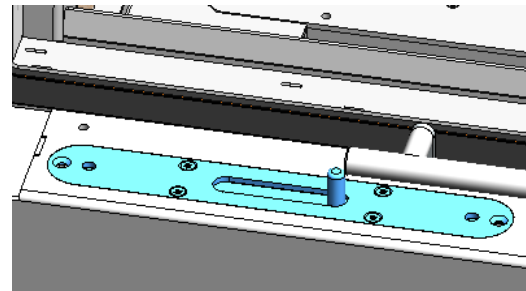

Figure No.49 - Removable registers

4.2. Maintenance of the chimney flue

VERY IMPORTANT: In order to avoid incidents (chimney fires, etc.), it is necessary to perform maintenance and cleaning operations on a regular basis; if the appliance is used often, then the chimney and the flue connector piping must be swept several times a year.

In the event of fire in the chimney, close the flue draught, close doors and windows, remove embers from the firebox, block the connection hole with damp cloths and call the fire brigade.

4.3. Important advice

Lacunza recommends that only Lacunza-authorized replacement parts be used.

Lacunza accepts no liability for any modification to the product which it has not authorized.







This appliance is a heat-producing appliance and contact may lead to burns.

This appliance may remain **HOT** for a period of time after it has gone out. **MAKE SURE THAT SMALL CHILDREN DO NOT GO NEAR IT.**

5. TROUBLESHOOTING



This symbol means that a qualified professional should be called to perform the operation.

Problem	Probable causes		Solution
The fire does not light properly The fire does not stay alight	Green or damp wood		Use hard woods, cut at least 2 years ago and stored in a sheltered, ventilated place
	The logs are too large		Use crumpled paper or firelighters and dry wood chips to light the fire. Use split logs to keep the fire going
	Poor-quality wood		Use hard woods which produce heat and embers (chestnut, ash, maple, birch, elm, beech, etc.)
	Insufficient primary air		Open the primary- and secondary-air intakes completely, or even open the door slightly. Open the outdoor-air inlet grille
	Insufficient updraught		Check that the draught is not blocked. De-soot if necessary. Check that the flue is in perfect condition (airtight, insulated, dry, etc.)
The fire flames up too much	Excessive primary air		Close the primary- and secondary-air intakes partially or totally
	Excessive updraught		Install a draught damper
Smoke given off on lighting	Poor-quality wood		Do not continually burn chips, carpentry scraps (plywood, pallets, etc.)
	Cold flue		Heat up the flue by burning a piece of paper in the firebox.
Smoke during burning	The room is at low pressure		In rooms with Controlled Mechanical Ventilation, leave an outdoor window ajar until the fire is fully alight.
	Too little wood loaded		Load as recommended. Loads notably smaller than those recommended lead to low smoke temperature and downdraught.
	Insufficient updraught		Check the condition of the flue and insulation. Check that the piping is not blocked. Clean mechanically if necessary
	Wind enters the flue		Install an anti-downdraught system (Cowl) at the top of the chimney
Does not warm up enough	The room is at low pressure		In rooms with Controlled Mechanical Ventilation, there must be an outdoor-air inlet
	Poor-quality wood		Only use the recommended fuel
The fans do not work	Electrical fault		

6. BASIC BREAKDOWNS

Figure No.50 - Itaca 80 eco Basic breakdowns

Nº	Código	Denominación	Cant.
1	5041200037	Marco exterior Itaca 80	1
2	5041200038	Cristal puerta 702x482 Itaca 80 sin serigrafía	1
3	504000000068	Cordón cerámico 15x10mm puerta Itaca 80	1
4	504000000058	Parrilla base hogar Itaca 80-100-120	1
5	504000000857	Cjto. sist. cierre puerta DCHA Itaca 80-100-120	1
6	504000000858	Cjto. sist. cierre puerta IZQDA Itaca 80-100-120	1
7	5041200036	Deflector inferior ITACA 80 Recer	1
8	504120000003	Deflector medio y superior ITACA 80	1

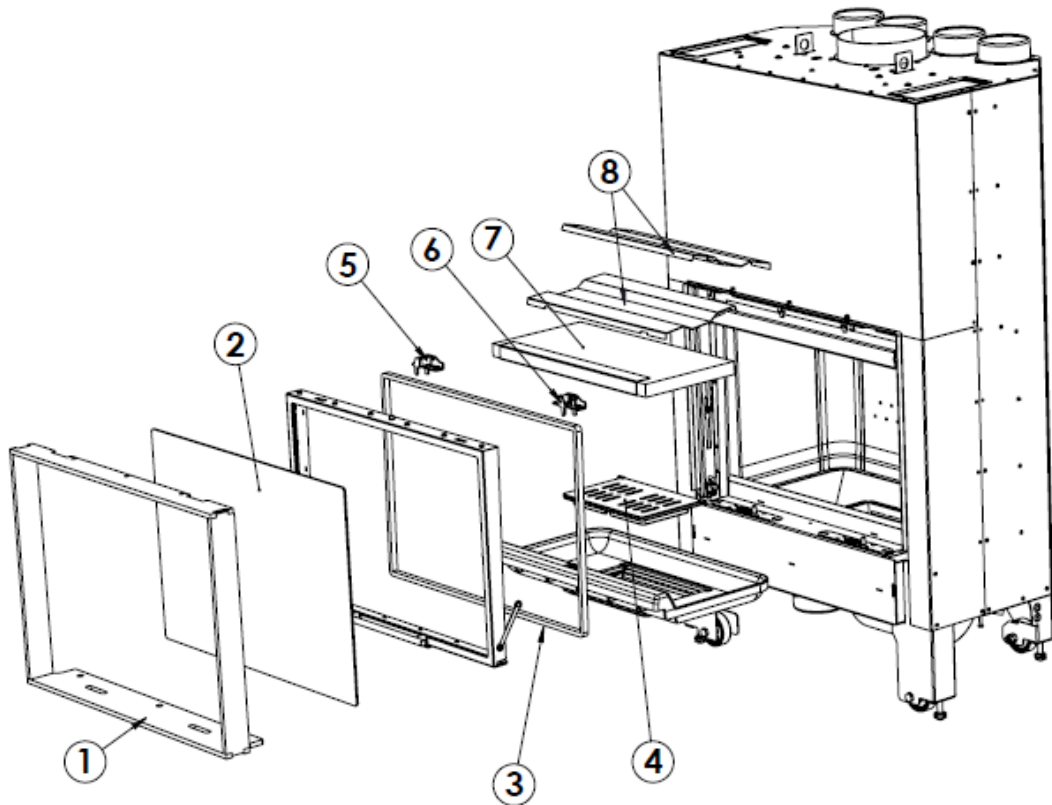
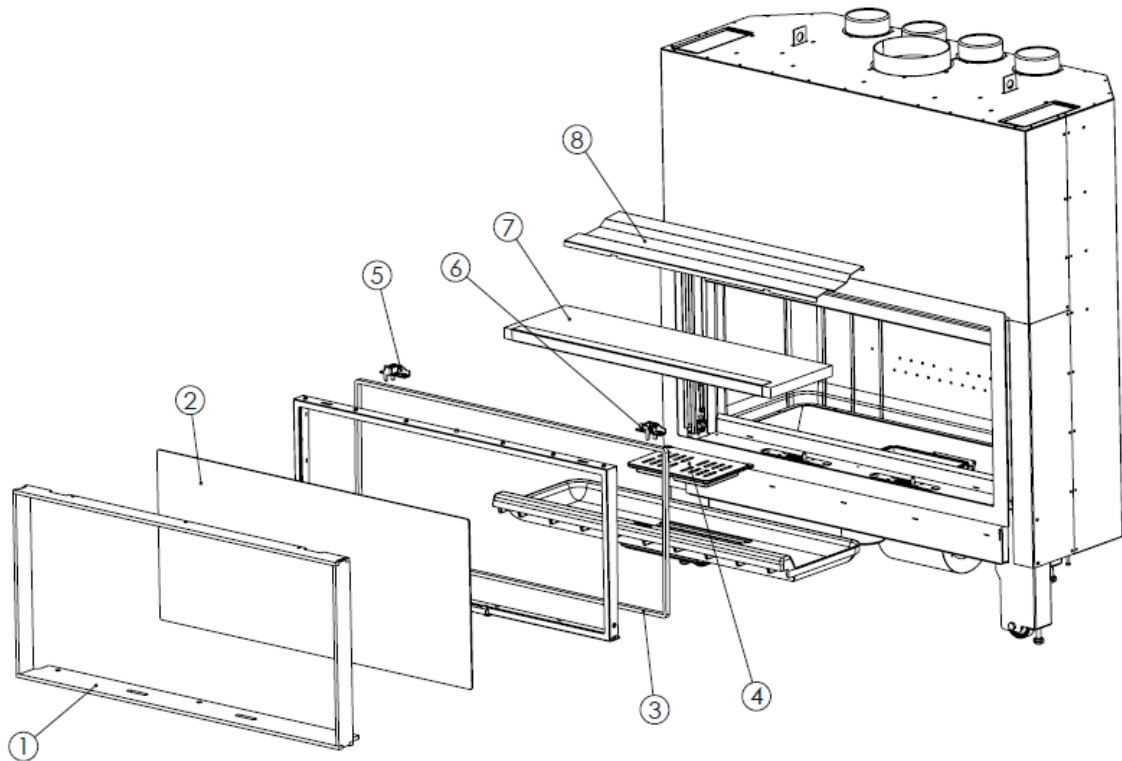
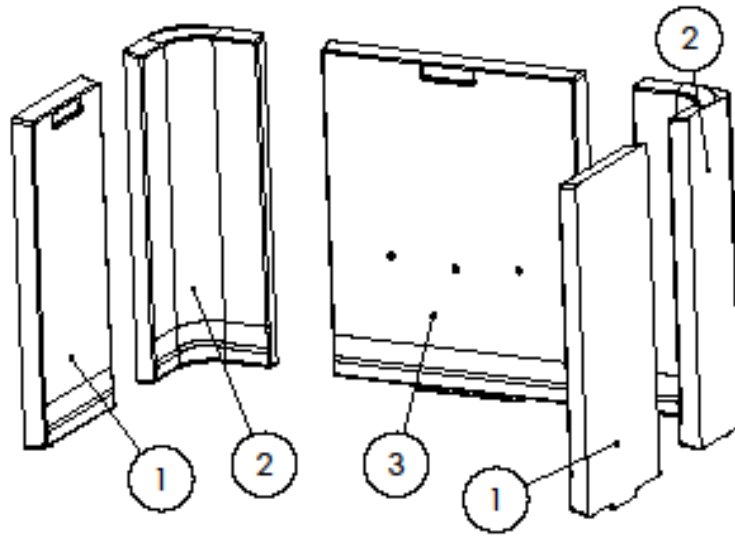
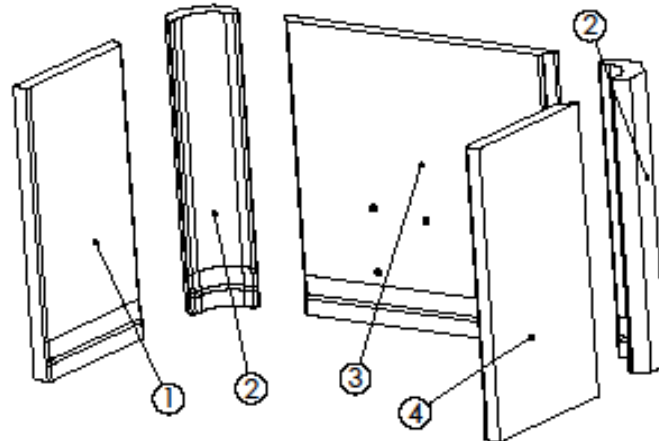

Figure No.51 - Itaca 100-120 eco Basic breakdowns

Nº	Código	Denominación	Cant.
1	5041400025	Marco exterior Itaca 100	1
	5041600030	Marco exterior Itaca 120	1
2	5041400026	Cristal puerta 902x482 Itaca 100 sin serigrafía	1
	5041600031	Cristal puerta 1102x482 Itaca 120 sin serigrafía	1
3	504000000068	Cordón cerámico 15x10mm puerta Itaca 100	1
	504000000068	Cordón cerámico 15x10mm puerta Itaca 120	1
4	504000000058	Parrilla base hogar Itaca 80-100-120	1
5	504000000857	Cjto. sist. cierre puerta DCHA Itaca 80-100-120	1
6	504000000858	Cjto. sist. cierre puerta IZQDA Itaca 80-100-120	1
7	5041400027	Deflector inferior ITACA 100 vermiculita	1
	5041600032	Deflector inferior ITACA 120 vermiculita	1
8	504140000003	Deflector medio ITACA 100	1
	504160000003	Deflector medio ITACA 120	1



Nº	N_PLANO	DENOMINACION	CANT.
1	504000000847	Refractario lateral izqdo-dcho ITACA-INCA Liso	2
2	504000000846	Refractario esquina izqdo-dcho ITACA-INCA Liso	2
3	504000000848	Refractario trasero ITACA-INCA Liso	1



Nº	N_PLANO	DENOMINACION	CANT.
1	504000000849	Refractario lateral izqdo itaca-inca vermiculita	1
2	504000000851	Refractario esquina izq-dcho ITACA Vermiculita	2
3	504000000852	Refractario trasero ITACA-INCA vermiculita	1
4	504000000850	Refractario lateral DCHO ITACA-INCA Vermiculita	1

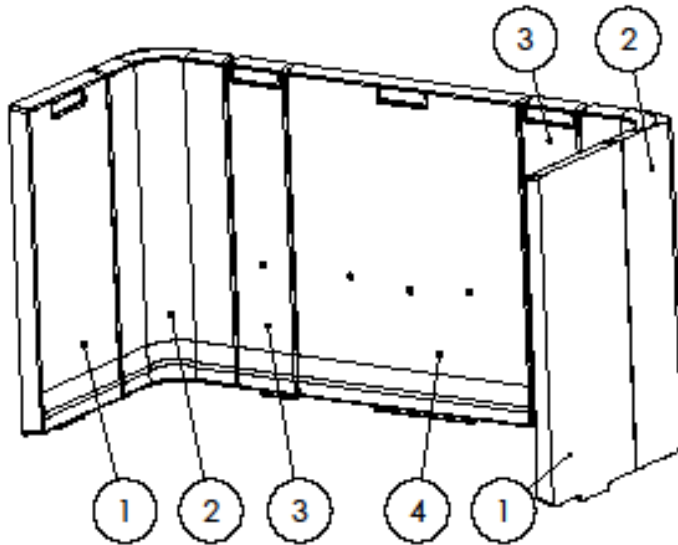

Nº	N_PLANO	DENOMINACION	CANT.
1	504000000847	Refractario lateral izqdo-dcho ITACA-INCA Liso	2
2	504000000846	Refractario esquina izqdo-dcho ITACA-INCA Liso	2
3	504000000842	Refractario trasero ITACA-INCA 100 Liso	2
4	504000000848	Refractario trasero ITACA-INCA Liso	1

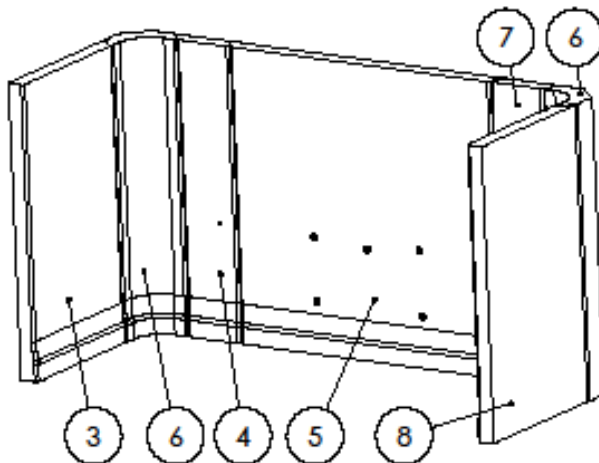

Nº	N_PLANO	DENOMINACION	CANT.
3	504000000849	Refractario lateral izqdo itaca-inca vermiculita	1
4	504000000853	Refractario trasero izquierdo Itaca-inca 100-120 Vermiculita	1
5	504000000852	Refractario trasero ITACA-INCA vermiculita	1
6	504000000851	Refractario esquina izq-dcho ITACA Vermiculita	2
7	504000000854	Refractario trasero DCHA. Itaca 100-120 Vermiculita	1
8	504000000850	Refractario lateral DCHO ITACA-INCA Vermiculita	1

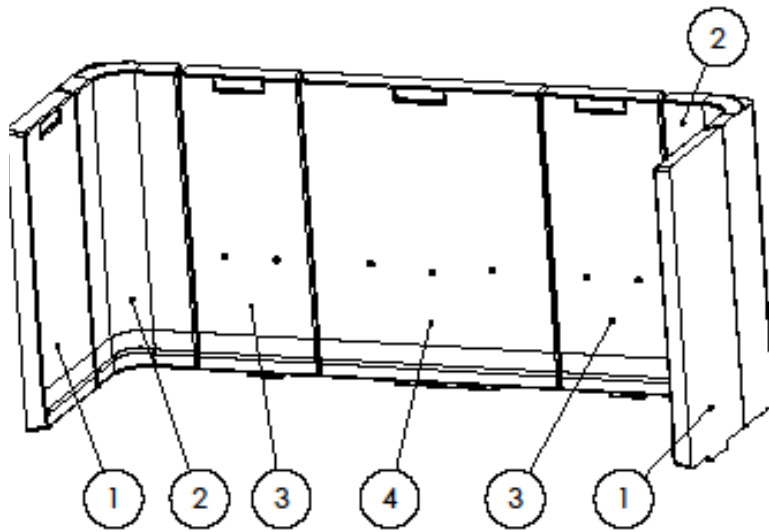

Nº	N_PLANO	DENOMINACION	CANT.
1	504000000847	Refractario lateral izqdo-dcho ITACA-INCA Liso	2
2	504000000846	Refractario esquina izqdo-dcho ITACA-INCA Liso	2
3	504000000844	Refractario trasero ITACA 120 Liso	2
4	504000000848	Refractario trasero ITACA-INCA Liso	1

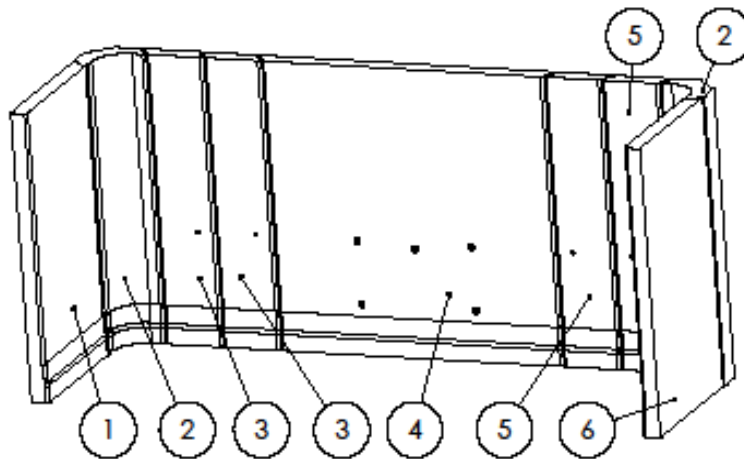

Nº	N_PLANO	DENOMINACION	CANT.
1	504000000849	Refractario lateral izqdo itaca-inca vermiculita	1
2	504000000851	Refractario esquina izq-dcho ITACA Vermiculita	2
3	504000000853	Refractario trasero izquierdo Itaca-inca 100-120 Vermiculita	2
4	504000000852	Refractario trasero ITACA-INCA vermiculita	1
5	504000000854	Refractario trasero DCHA. Itaca 100-120 Vermiculita	2
6	504000000850	Refractario lateral DCHO ITACA-INCA Vermiculita	1

7. RECYCLING DE PRODUCT

The recycling of the appliance is the exclusive responsibility of the owner, who must act in compliance with the laws in force in his country regarding safety, respect and protection of the environment. At the end of its useful life, the product must not be disposed of with urban waste.

It can be delivered to the specific selective collection centers set up by the municipalities, or to retailers who offer this service. The selective disposal of the product avoids possible negative consequences for the environment and for health and makes it possible to recover the materials of which it is composed, thus obtaining significant savings in terms of energy and resources.

It can be disassembled (the parts are assembled with screws or rivets) and the components can be deposited in their corresponding recycling channels. The components of the appliance are: steel, cast iron, glass, insulating materials, electrical material, etc.

8. DECLARATION OF PERFORMANCE



CH-S-011

DECLARACIÓN DE PRESTACIONES Conforme al R. E. Productos Construcción (UE) Nº 305/2011

DÉCLARATION DE PERFORMANCE Selon le Règlement (UE) Nº 305/2011

DICHIARAZIONE DI PRESTAZIONE In base al Regolamento (UE) Nº 305/2011

DECLARATION OF PERFORMANCE According to Regulation (UE) Nº 305/2011

DECLARAÇÃO DE PRESTAÇÕES Em base com o Regulamento (UE) Nº 305/2011

- Nombre y/o código de identificación única del producto:
Nom-code d'identification unique du produit
Nome-codice identificativo unico del prodotto
Unique identifier nome-code for product
Nome-código de identificação único do produto
 - Marca, marque, marca, mark, marca: **Lacunza**
 - Tipo, type, tipo, type, tipo: **Insertable, Appareil insérable, Apparecchio a incasso, Insertable appliance, Aparelho encastrável**
 - Modelo, modèle, modello, model, modelo: **ITACA80 ECO, ITACA80 ECO C/V, ITACA80 ECO V, ITACA80 ECO V C/V**
- Uso o usos previstos del producto:** Aparato insertable de carga manual, para quemar combustibles sólidos (indicado en instrucciones), cuya función es calentar el espacio en el que está instalado.
Utilisation prévue du produit: Appareil insérable qui se charge manuellement, conçu pour brûler des combustibles solides (indiqués dans le Manuel d'Instructions), dont la fonction est de chauffer l'espace où il est installé.
Usi previsti del prodotto: Apparecchio a incasso a carico manuale, per bruciare combustibili solidi (indicati nelle istruzioni), la cui funzione è riscaldare lo spazio in cui è installato.
Entended uses of the product: Insertable appliance to be loaded by hand and designed to burn solid fuels (indicated in instructions), whose function is to heat the space in which it is installed.
Utilização prevista do produto: Aparelho encastrável de carga manual, para queimar combustíveis sólidos (indicado nas instruções), cuja função é aquecer o espaço no qual está instalado.
- Nombre y dirección del fabricante: **LACUNZA KALOR GROUP S.A.L.**
Nom et adresse du fabricant: **Pol. Ind. Ibarrea 5A 31800 Alsasua (Navarra) (España)**
Nome e indirizzo del fabbricante: **Téléfono: (0034) 948563511**
Name and adress of the manufacturer: **Fax: (0034) 948563505**
Nome e endereço do fabricante: **Email: comercial@lacunza.net**
- Sistema de evaluación y verificación de la constancia de las prestaciones: **3**
Système d'évaluation et contrôle de la constante de performance: **3**
Sistema di valutazione e verifica della costanza della prestazione: **3**
Assessment and verification system for constancy of performance: **3**
Sistema de avaliação e verificação da regularidade do desempenho: **3**
- Organismo Notificado, Laboratoire notifié, Laboratorio notificato, Laboratory notified, Laboratório notificado:
RRF Nº NB1625 Rhein-Ruhr Feuerstätten
Prüfstelle GmbH
Am Technologie Park 1 D-45307 ESSEN
Por el sistema, Selon le system, In base al system, Based on system, Em base ao system : **3**
Documento emitido (fecha), Numéro du rapport d'essai (date), Numero rapporto di prova (data), Test report number (date), Número relação de prova (data): **29195193 (04-04-2019)**

6. Prestaciones declaradas, Performance déclarée, Prestazioni dichiarate, Services declare, Desempenhos declarados:

Especificaciones técnicas armonizadas, Spécifications techniques armoniques, Specifica tecnica armonizzata, Harmonised technical specifications, Especifica técnica harmonizada EN13229:2001/A2:2004/AC:2007											
Características esenciales, Caractéristiques essentielles, Caratteristiche essenziali, Essential features, Características essenciais	Prestaciones, Performance, Prestazione, Services, Desempenho										
Reacción al fuego, Réaction au feu, Reazione al fuoco, Reaction to fire, Reação ao fogo	Cumple, Conforme, Conforme, Compliant, Em Conformidade										
Distancia mínima de seguridad a materiales combustibles, Distance minimum aux matériaux combustibles, Distanza minima da materiali combustibili, Minimum distance from combustible material, Distância mínimo de materiais combustíveis	<table border="1"> <tr> <td>Izquierda, gauche, sinistra, left, esquerda:</td> <td>200mm</td> </tr> <tr> <td>Derecha, droite, diritto, right, direito:</td> <td>200mm</td> </tr> <tr> <td>Trasera, arrière, retro, back, traseira:</td> <td>300mm</td> </tr> <tr> <td>Delantera, avant, fronte, front, frente:</td> <td>1000mm</td> </tr> <tr> <td>Encimera, dessus, sopra, above, acima:</td> <td>750mm</td> </tr> </table>	Izquierda, gauche, sinistra, left, esquerda:	200mm	Derecha, droite, diritto, right, direito:	200mm	Trasera, arrière, retro, back, traseira:	300mm	Delantera, avant, fronte, front, frente:	1000mm	Encimera, dessus, sopra, above, acima:	750mm
Izquierda, gauche, sinistra, left, esquerda:	200mm										
Derecha, droite, diritto, right, direito:	200mm										
Trasera, arrière, retro, back, traseira:	300mm										
Delantera, avant, fronte, front, frente:	1000mm										
Encimera, dessus, sopra, above, acima:	750mm										
Temperatura humos a potencia térmica nominal, Température des fumées, Temperatura fumi, Fume temperatura, Temperatura dos gases de combustão	212 °C										
Emisión, Emission, Emissione, Emissão, Emission, CO 13% O2	0,08 %										
Emisión, Emission, Emissione, Emissão, Emission, CO 13% O2	1000 mg/Nm ³										
Emisión, Emission, Emissione, Emissão, Emission, NOx 13% O2	121 mg/Nm ³										
Emisión, Emission, Emissione, Emissão, Emission, OGC 13% O2	39 mg/Nm ³										
Emisión, Emission, Emissione, Emissão, Emission, PM 13% O2	20 mg/Nm ³										
Desprendimiento de sustancias peligrosas, Rejet de substances dangereuses, Rilascio di sostanze pericolose, Release of hazardous substances, Lançamento de substâncias perigosas	Cumple, Conforme, Conforme, Compliant, Em Conformidade										
Temperatura superficial, Température de surface, Temperatura superficiale, Surface temperatura, Temperatura superficial	Cumple, Conforme, Conforme, Compliant, Em Conformidade										
Seguridad eléctrica, Sécurité électrique, Sicurezza elettrica, Electrical safety, Segurança elétrica	Cumple, Conforme, Conforme, Compliant, Em Conformidade										
Presión máxima de servicio (paila), Pression maximale de service, Máxima pressione di esercizio, Maxim operating pressure, Máxima pressão de exercício	-										
Resistencia mecánica (para soportar una chimenea/un conducto de humos), Résistance mécanique (pour soutenir la cheminée), Resistenza mecánica (per supportare il camino), Mechanical strength (to support the fireplace), Resistência mecânica (para suportar a chaminé)	Cumple, Conforme, Conforme, Compliant, Em Conformidade										
Potencia térmica ambiente, Puissance rendue au milieu, Potenza resa all'ambiente, Power output to the environment, Potência libertada no ambiente	12 kW										
Potencia térmica agua, Puissance rendue à l'eau, Potenza ceduta all'acqua, Power transferred to water, Potência cedida à água	-										
Rendimiento energético, Rendement, Rendimento, Efficiency, Atuação	85,2 %										

Las prestaciones del producto identificado en el punto 1 son conformes con las prestaciones declaradas en el punto 6.
 La performance du produit citée au point 1 est conforme à la performance declare au point 6.
 La prestazione del prodotto di cui ai punti 1 è conforme alla prestazione dichiarata di cui al punto 6.
 The performance of the product referred to in point 1 is consistent with the declared performance in point 6.
 As declarações do produto identificado no ponto 1, estão conformes com as prestações declaradas no ponto 6.

La presente declaración de prestaciones se emite bajo la única responsabilidad del fabricante, indicado en el punto 3.
 Cette déclaration de performance est délivrée sous la responsabilité exclusive du fabricant cité au point 3.
 Si rilascia la presente dichiarazione di prestazione sotto la responsabilità esclusiva del fabricante di cui al punto 3.
 This declaration of performance is issued under the manufacturer's sole responsibility referred to in point 3.
 É emitida a presente declaração de desempenho sob a responsabilidade exclusiva do fabricante referido no ponto 3.



Lacunza Kalar Group S.A.
 NIF A-31606932
 Polígono Industrial Ibarrea s/n
 31800 Alsasua (Navarra) Spain

José Julián Garciandía Pellejero
 Director Gerente

Alsasua 25-04-2019



CH-S-012

DECLARACIÓN DE PRESTACIONES Conforme al R. E. Productos Construcción (UE) Nº 305/2011**DÉCLARATION DE PERFORMANCE** Selon le Règlement (UE) Nº 305/2011**DICHIARAZIONE DI PRESTAZIONE** In base al Regolamento (UE) Nº 305/2011**DECLARATION OF PERFORMANCE** According to Regulation (UE) Nº 305/2011**DECLARAÇÃO DE PRESTAÇÕES** Em base com o Regulamento (UE) Nº 305/2011

- Nombre y/o código de identificación única del producto:
Nom-code d'identification unique du produit
Nome-codice identificativo unico del prodotto
Unique identifier nome-code for product
Nome-código de identificação único do produto
 - Marca, marque, marca, mark, marca: **Lacunza**
 - Tipo, type, tipo, type, tipo: **Insertable, Appareil insérable, Apparecchio a incasso, Insertable appliance, Aparelho encastrável**
 - Modelo, modèle, modello, model, modelo: **ITACA100 ECO, ITACA100 ECO C/V, ITACA100 ECO V, ITACA100 ECO V C/V**
- Uso o usos previstos del producto:** Aparato insertable de carga manual, para quemar combustibles sólidos (indicado en instrucciones), cuya función es calentar el espacio en el que está instalado.
Utilisation prévue du produit: Appareil insérable qui se charge manuellement, conçu pour brûler des combustibles solides (indiqués dans le Manuel d'Instructions), dont la fonction est de chauffer l'espace où il est installé.
Usi previsti del prodotto: Apparecchio a incasso a carico manuale, per bruciare combustibili solidi (indicati nelle istruzioni), la cui funzione è riscaldare lo spazio in cui è installato.
Intended uses of the product: Insertable appliance to be loaded by hand and designed to burn solid fuels (indicated in instructions), whose function is to heat the space in which it is installed.
Utilização prevista do produto: Aparelho encastrável de carga manual, para queimar combustíveis sólidos (indicado nas instruções), cuja função é aquecer o espaço no qual está instalado.
- Nombre y dirección del fabricante: **LACUNZA KALOR GROUP S.A.L.**
Nom et adresse du fabricant: **Pol. Ind. Ibarrea 5A 31800 Alsasua (Navarra) (España)**
Nome e indirizzo del fabbricante: **Téléfono: (0034) 948563511**
Name and address of the manufacturer: **Fax: (0034) 948563505**
Nome e endereço do fabricante: **Email: comercial@lacunza.net**
- Sistema de evaluación y verificación de la constancia de las prestaciones: **3**
Système d'évaluation et contrôle de la constante de performance: **3**
Sistema di valutazione e verifica della costanza della prestazione: **3**
Assessment and verification system for constancy of performance: **3**
Sistema de avaliação e verificação da regularidade do desempenho: **3**
- Organismo Notificado, Laboratoire notifié, Laboratorio notificato, Laboratory notified, Laboratório notificado:
STROJÍRENSKÝ ZKUŠEBNÍ ÚSTAV, S.P.
Engineering Test Institute, Public Enterprise
Hudcova 424/56b, 621 00 Brno, Czech Republic. Notified Body 1015
Por el sistema, Selon le system, In base al system, Based on system, Em base ao system : **3.**
Documento emitido (fecha), Numéro du rapport d'essai (date), Numero rapporto di prova (data), Test report number (date), Número relação de prova (data): **CPR-B-00405-21 (16-03-2021)**

6. Prestaciones declaradas, Performance déclarée, Prestazioni dichiarate, Services declare, Desempenhos declarados:

Especificaciones técnicas armonizadas, Spécifications techniques armoniques, Specifica tecnica armonizzata, Harmonised technical specifications, Especifica técnica harmonizada EN13229:2001/A2:2004/AC:2007	
Características esenciales, Caractéristiques essentielles, Caratteristiche essenziali, Essential features, Características essenciais	Prestaciones, Performance, Prestazione, Services, Desempenho
Reacción al fuego, Réaction au feu, Reazione al fuoco, Reaction to fire, Reação ao fogo	Cumple, Conforme, Conforme, Compliant, Em Conformidade
Distancia mínima de seguridad a materiales combustibles, Distance minimum aux matériaux combustibles, Distanza minima da materiali combustibili, Minimum distance from combustible material, Distância mínimo de materiais combustíveis	Izquierda, gauche, sinistra, left, esquerda: 400mm Derecha, droite, diritto, right, direito: 400mm Trasera, arrière, retro, back, traseira: 400mm Delantera, avant, fronte, front, frente: 1600mm Encimera, dessus, sopra, above, acima: 800mm
Temperatura humos a potencia térmica nominal, Température des fumées, Temperatura fumi, Fume temperatura, Temperatura dos gases de combustão	245 °C
Emisión, Emission, Emissione, Emissão, Emission, CO 13% O2	0,08 %
Emisión, Emission, Emissione, Emissão, Emission, CO 13% O2	1056 mg/Nm³
Emisión, Emission, Emissione, Emissão, Emission, NOx 13% O2	121 mg/Nm³
Emisión, Emission, Emissione, Emissão, Emission, OGC 13% O2	66 mg/Nm³
Emisión, Emission, Emissione, Emissão, Emission, PM 13% O2	25 mg/Nm³
Desprendimiento de sustancias peligrosas, Rejet de substances dangereuses, Rilascio di sostanze pericolose, Release of hazardous substances, Lançamento de substâncias perigosas	Cumple, Conforme, Conforme, Compliant, Em Conformidade
Temperatura superficial, Température de surface, Temperatura superficiale, Surface temperatura, Temperatura superficial	Cumple, Conforme, Conforme, Compliant, Em Conformidade
Seguridad eléctrica, Sécurité électrique, Sicurezza elettrica, Electrical safety, Segurança elétrica	Cumple, Conforme, Conforme, Compliant, Em Conformidade
Presión máxima de servicio (paila), Pression maximale de service, Máxima pressione di esercizio, Maximum operating pressure, Máxima pressão de exercício	-
Resistencia mecánica (para soportar una chimenea/un conducto de humos), Résistance mécanique (pour soutenir la cheminée), Resistenza mecánica (per supportare il camino), Mechanical strength (to support the fireplace), Resistência mecânica (para suportar a chaminé)	Cumple, Conforme, Conforme, Compliant, Em Conformidade
Potencia térmica ambiente, Puissance rendue au milieu, Potenza resa all'ambiente, Power output to the environment, Potência libertada no ambiente	13 kW
Potencia térmica agua, Puissance rendue à l'eau, Potenza ceduta all'acqua, Power transferred to water, Potência cedida à água	-
Rendimiento energético, Rendement, Rendimento, Efficiency, Atuação	79,5 %

Las prestaciones del producto identificado en el punto 1 son conformes con las prestaciones declaradas en el punto 6.
La performance du produit cité au point 1 est conforme à la performance declare au point 6.
La prestazione del prodotto di cui ai punti 1 è conforme alla prestazione dichiarata di cui al punto 6.
The performance of the product referred to in point 1 is consistent with the declared performance in point 6.
As declarações do produto identificado no ponto 1, estão conformes com as prestações declaradas no ponto 6.

La presente declaración de prestaciones se emite bajo la única responsabilidad del fabricante, indicado en el punto 3.
Cette déclaration de performance est délivrée sous la responsabilité exclusive du fabricant cité au point 3.
Si rilascia la presente dichiarazione di prestazione sotto la responsabilità esclusiva del fabricante di cui al punto 3.
This declaration of performance is issued under the manufacturer's sole responsibility referred to in point 3.
É emitida a presente declaração de desempenho sob a responsabilidade exclusiva do fabricante referido no ponto 3.



José Julián Garcandía Pellejero
Director Gerente

Alsasua 29-09-2021



CH-S-013

DECLARACIÓN DE PRESTACIONES Conforme al R. E. Productos Construcción (UE) Nº 305/2011**DÉCLARATION DE PERFORMANCE** Selon le Règlement (UE) Nº 305/2011**DICHIARAZIONE DI PRESTAZIONE** In base al Regolamento (UE) Nº 305/2011**DECLARATION OF PERFORMANCE** According to Regulation (UE) Nº 305/2011**DECLARAÇÃO DE PRESTAÇÕES** Em base com o Regulamento (UE) Nº 305/2011

- Nombre y/o código de identificación única del producto:
Nom-code d'identification unique du produit
Nome-codice identificativo unico del prodotto
Unique identifier nome-code for product
Nome-código de identificação único do produto
 - Marca, marque, marca, mark, marca: **Lacunza**
 - Tipo, type, tipo, type, tipo: **Insertable, Appareil insérable, Apparechio a incasso, Insertable appliance, Aparelho encastrável**
 - Modelo, modèle, modello, model, modelo: **ITACA120 ECO, ITACA120 ECO C/V, ITACA120 ECO V, ITACA120 ECO V C/V**
- Uso o usos previstos del producto:** Aparato insertable de carga manual, para quemar combustibles sólidos (indicado en instrucciones), cuya función es calentar el espacio en el que está instalado.
Utilisation prévue du produit: Appareil insérable qui se charge manuellement, conçu pour brûler des combustibles solides (indiqués dans le Manuel d'Instructions), dont la fonction est de chauffer l'espace où il est installé.
Usi previsti del prodotto: Apparechio a incasso a carico manuale, per bruciare combustibili solidi (indicati nelle istruzioni), la cui funzione è riscaldare lo spazio in cui è installato.
Entended uses of the product: Insertable appliance to be loaded by hand and designed to burn solid fuels (indicated in instructions), whose function is to heat the space in which it is installed.
Utilização prevista do produto: Aparelho encastrável de carga manual, para queimar combustíveis sólidos (indicado nas instruções), cuja função é aquecer o espaço no qual está instalado.
- Nombre y dirección del fabricante: **LACUNZA KALOR GROUP S.A.L.**
Nom et adresse du fabricant: **Pol. Ind. Ibarrea 5A 31800 Alsasua (Navarra) (España)**
Nome e indirizzo del fabbricante: **Télefono: (0034) 948563511**
Name and adress of the manufacturer: **Fax: (0034) 948563505**
Nome e endereço do fabricante: **Email: comercial@lacunza.net**
- Sistema de evaluación y verificación de la constancia de las prestaciones: **3**
Système d'évaluation et contrôle de la constante de performance: **3**
Sistema di valutazione e verifica della costanza della prestazione: **3**
Assessment and verification system for constancy of performance: **3**
Sistema de avaliação e verificação da regularidade do desempenho: **3**
- Organismo Notificado, Laboratoire notifié, Laboratorio notificato, Laboratory notified, Laboratório notificado:
STROJÍRENSKÝ ZKUŠEBNÍ ÚSTAV, S.P.
Engineering Test Institute, Public Enterprise
Hudcova 424/56b, 621 00 Brno, Czech Republic. Notified Body 1015
Por el sistema, Selon le system, In base al system, Based on system, Em base ao system : **3.**
Documento emitido (fecha), Numéro du rapport d'essai (date), Numero rapporto di prova (data), Test report number (date), Número relação de prova (data): **CPR-B-00405-21 (16-03-2021)**

6. Prestaciones declaradas, Performance déclarée, Prestazioni dichiarate, Services declare, Desempenhos declarados:

Especificaciones técnicas armonizadas, Spécifications techniques armoniques, Specifica tecnica armonizzata, Harmonised technical specifications, Especifica técnica harmonizada EN13229:2001/A2:2004/AC:2007											
Características esenciales, Caractéristiques essentielles, Caratteristiche essenziali, Essential features, Características essenciais	Prestaciones, Performance, Prestazione, Services, Desempenho										
Reacción al fuego, Réaction au feu, Reazione al fuoco, Reaction to fire, Reação ao fogo	Cumple, Conforme, Conforme, Compliant, Em Conformidade										
Distancia mínima de seguridad a materiales combustibles, Distance minimum aux matériaux combustibles, Distanza minima da materiali combustibili, Minimum distance from combustible material, Distância mínimo de materiais combustíveis	<table border="1"> <tr> <td>Izquierda, gauche, sinistra, left, esquerda:</td> <td>400mm</td> </tr> <tr> <td>Derecha, droite, diritto, right, direito:</td> <td>400mm</td> </tr> <tr> <td>Trasera, arrière, retro, back, traseira:</td> <td>400mm</td> </tr> <tr> <td>Delantera, avant, fronte, front, frente:</td> <td>1600mm</td> </tr> <tr> <td>Encimera, dessus, sopra, above, acima:</td> <td>800mm</td> </tr> </table>	Izquierda, gauche, sinistra, left, esquerda:	400mm	Derecha, droite, diritto, right, direito:	400mm	Trasera, arrière, retro, back, traseira:	400mm	Delantera, avant, fronte, front, frente:	1600mm	Encimera, dessus, sopra, above, acima:	800mm
Izquierda, gauche, sinistra, left, esquerda:	400mm										
Derecha, droite, diritto, right, direito:	400mm										
Trasera, arrière, retro, back, traseira:	400mm										
Delantera, avant, fronte, front, frente:	1600mm										
Encimera, dessus, sopra, above, acima:	800mm										
Temperatura humos a potencia térmica nominal, Température des fumées, Temperatura fumi, Fume temperatura, Temperatura dos gases de combustão	245 °C										
Emisión, Emission, Emissione, Emissão, Emission, CO 13% O2	0,08 %										
Emisión, Emission, Emissione, Emissão, Emission, CO 13% O2	1056 mg/Nm ³										
Emisión, Emission, Emissione, Emissão, Emission, NOx 13% O2	87 mg/Nm ³										
Emisión, Emission, Emissione, Emissão, Emission, OGC 13% O2	66 mg/Nm ³										
Emisión, Emission, Emissione, Emissão, Emission, PM 13% O2	25 mg/Nm ³										
Desprendimiento de sustancias peligrosas, Rejet de substances dangereuses, Rilascio di sostanze pericolose, Release of hazardous substances, Lançamento de substâncias perigosas	Cumple, Conforme, Conforme, Compliant, Em Conformidade										
Temperatura superficial, Température de surface, Temperatura superficiale, Surface temperatura, Temperatura superficial	Cumple, Conforme, Conforme, Compliant, Em Conformidade										
Seguridad eléctrica, Sécurité électrique, Sicurezza elettrica, Electrical safety, Segurança elétrica	Cumple, Conforme, Conforme, Compliant, Em Conformidade										
Presión máxima de servicio (paila), Pression maximale de service, Máxima pressione di esercizio, Maximun operating pressure, Máxima pressão de exercício	-										
Resistencia mecánica (para soportar una chimenea/un conducto de humos), Résistance mécanique (pour soutenir la cheminée), Resistenza mecánica (per supportare il camino), Mechanical strength (to support the fireplace), Resistência mecânica (para suportar a chaminé)	Cumple, Conforme, Conforme, Compliant, Em Conformidade										
Potencia térmica ambiente, Puissance rendue au milieu, Potenza resa all'ambiente, Power output to the environment, Potência libertada no ambiente	14 kW										
Potencia térmica agua, Puissance rendue à l'eau, Potenza ceduta all'acqua, Power transferred to water, Potência cedida à água	-										
Rendimiento energético, Rendement, Rendimento, Efficiency, Atuação	79,5 %										

Las prestaciones del producto identificado en el punto 1 son conformes con las prestaciones declaradas en el punto 6.
 La performance du produit citée au point 1 est conforme à la performance declare au point 6.
 La prestazione del prodotto di cui ai punti 1 è conforme alla prestazione dichiarata di cui al punto 6.
 The performance of the product referred to in point 1 is consistent with the declared performance in point 6.
 As declarações do produto identificado no ponto 1, estão conformes com as prestações declaradas no ponto 6.

La presente declaración de prestaciones se emite bajo la única responsabilidad del fabricante, indicado en el punto 3.
 Cette déclaration de performance est délivrée sous la responsabilité exclusive du fabricant cité au point 3.
 Si rilascia la presente dichiarazione di prestazione sotto la responsabilità esclusiva del fabricante di cui al punto 3.
 This declaration of performance is issued under the manufacturer's sole responsibility referred to in point 3.
 É emitida a presente declaração de desempenho sob a responsabilidade exclusiva do fabricante referido no ponto 3.



José Julián Garcandía Pellejero
 Director Gerente

Alsasua 29-09-2021

9. CE MARK

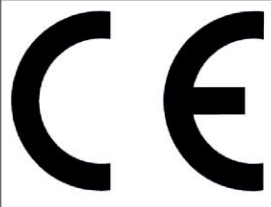
	LACUNZA KALOR GROUP S.A.L. Pol. Ind. Ibarrea 5A 31800 Alsasua (Navarra) (Spain)
Marca, marque, marca, mark, marca: Lacunza Tipo, type, tipo, type, tipo: Insertable, Appareil insérable, Apparecchio a incasso, Insertable appliance, Aparelho encastrável Modelo, modèle, modello, model, modelo: ITACA80 ECO, ITACA80 ECO C/V, ITACA80 ECO V, ITACA80 ECO V C/V	Número, Nombre, Numero, Number, Número: CH-S-011 Organismo notificado, Laboratoire notifié, Laboratorio notificato, Laboratory notified, Laboratorio notificado: RRF Nº NB1625
Aparato Tipo, Type d'appareil, Tipo di apparecchio, Apparatus Type, Tipo de aparelho: BE	
<p>Chimenea de carga manual, para quemar combustibles sólidos (indicado en instrucciones), cuya función es calentar el espacio en el que está instalada. Funcionamiento Intermitente. Para conducto humos no compartido.</p> <p>Appareil insérable qui se charge manuellement, conçu pour brûler des combustibles solides (indiqués dans le Manuel d'Instructions), dont la fonction est de chauffer l'espace où il est installé. Fonctionnement intermittent. Pour conduit non partagé.</p> <p>Apparecchio a incasso a carico manuale, per bruciare combustibili solidi (indicati nelle istruzioni), la cui funzione è riscaldare lo spazio in cui è installato. Funzionamento intermittente. Per condotto non condiviso.</p> <p>Insertable appliance to be loaded by hand and designed to burn solid fuels (indicated in instructions), whose function is to heat the space in which it is installed. Intermittent operation. For non-shared conduit.</p> <p>Aparelho encastrável de carga manual, para queimar combustíveis sólidos (indicado nas instruções), cuja função é aquecer o espaço no qual está instalado. Operação intermitente. Para conduíte não compartilhado.</p>	
<p align="center">EN13229:2001/A2:2004/AC:2007</p>	
<p>Características esenciales, Caractéristiques essentielles, Caratteristiche essenziali, Essential features, Características essenciais</p> <p>Reacción al fuego, Réaction au feu, Reazione al fuoco, Reaction to fire, Reação ao fogo</p>	<p>Prestaciones, Performance, Prestazione, Services, Desempenho</p> <p>Cumple, Conforme, Conforme, Compliant, Em Conformidade</p>
Distancia mínima de seguridad a materiales combustibles, Distance minimum aux matériaux combustibles, Dintanza minima da materiali combustibili, Minimum distance from combustible material, Distância mínimo de materiais combustíveis	<p>Izquierda, gauche, sinistra, left, esquerda: 200mm Derecha, droite, diritto, right, direito: 200mm Trasera, arrière, retro, back, traseira: 300mm Delantera, avant, fronte, front, frente: 1000mm Encimera, dessus, sopra, above, acima: 750mm</p>
Temperatura humos a potencia térmica nominal, Température des fumées, Temperatura fumi, Fume temperatura, Temperatura dos gases de combustão	<p align="center">212 °C</p>
Emisión productos combustión, Emisión des produits de combustion, Emisión prodotti combustione, Combustión productos emissions, Emissões de produtos de combustão	<p align="center">Cumple, Conforme, Conforme, Compliant, Em Conformidade</p>
Emisión, Emission, Emissione, Emissão, Emission, CO 13% O2	<p align="center">0,08 %</p>
Emisión, Emission, Emissione, Emissão, Emission, CO 13% O2	<p align="center">1000 mg/Nm³</p>
Emisión, Emission, Emissione, Emissão, Emission, NOx 13% O2	<p align="center">121 mg/Nm³</p>
Emisión, Emission, Emissione, Emissão, Emission, OGC 13% O2	<p align="center">39 mg/Nm³</p>
Emisión, Emission, Emissione, Emissão, Emission, PM 13% O2	<p align="center">20 mg/Nm³</p>
Desprendimiento de sustancias peligrosas, Rejet de substances dangereuses, Rilascio di sostanze pericolose, Release of hazardous substances, Lançamento de substâncias perigosas	<p align="center">Cumple, Conforme, Conforme, Compliant, Em Conformidade</p>
Temperatura superficial, Température de surface, Temperatura superficiale, Surface temperatura, Temperatura superficial	<p align="center">Cumple, Conforme, Conforme, Compliant, Em Conformidade</p>
Seguridad eléctrica, Sécurité électrique, Sicurezza elettrica, Electrical safety, Segurança elétrica	<p align="center">Cumple, Conforme, Conforme, Compliant, Em Conformidade</p>
Resistencia mecánica (para soportar una chimenea/un conducto de humos), Résistance mécanique (pour soutenir la cheminée), Resistenza mecánica (per supportare il camino), Mechanical strength (to support the fireplace), Resistência mecânica (para suportar a chaminé)	<p align="center">Cumple, Conforme, Conforme, Compliant, Em Conformidade</p>
Potencia térmica ambiente, Puissance rendue au milieu, Potenza resa all'ambiente, Power output to the environment, Potência libertada no ambiente	<p align="center">12 kW</p>
Potencia térmica agua, Puissance rendue à l'eau, Potenza ceduta all'acqua, Power transferred to wáter, Potência cedida à água	<p align="center">-</p>
Rendimiento energético, Rendement, Rendimento, Efficiency, Atuação	<p align="center">85,2 %</p>

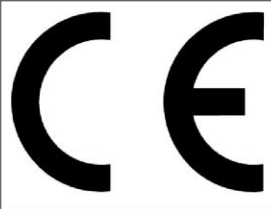
	LACUNZA KALOR GROUP S.A.L. Pol. Ind. Ibarrea 5A 31800 Alsasua (Navarra) (Spain)
09	Número, Nombre, Numero, Number, Número: CH-S-012
Marca, marque, marca, mark, marca: Lacunza Tipo, type, tipo, type, tipo: Insertable, Appareil insérable, Apparecchio a incasso, Insertable appliance, Aparelho encastrável Modelo, modèle, modello, model, modelo: ITACA100 ECO, ITACA100 ECO C/V, ITACA100 ECO V, ITACA100 ECO V C/V	Organismo notificado, Laboratoire notifié, Laboratorio notificado, Laboratory notified, Laboratorio notificado: SZU N° 1015
Aparato Tipo, Type d'appareil, Tipo di apparecchio, Apparatus Type, Tipo de aparelho: BE	
<p>Chimenea de carga manual, para quemar combustibles sólidos (indicado en instrucciones), cuya función es calentar el espacio en el que está instalada. Funcionamiento Intermitente. Para conducto humos no compartido.</p> <p>Appareil insérable qui se charge manuellement, conçu pour brûler des combustibles solides (indiqués dans le Manuel d'Instructions), dont la fonction est de chauffer l'espace où il est installé. Fonctionnement intermittent. Pour conduit non partagé.</p> <p>Apparecchio a incasso a carico manuale, per bruciare combustibili solidi (indicati nelle istruzioni), la cui funzione è riscaldare lo spazio in cui è installato. Funzionamento intermittente. Per condotto non condiviso.</p> <p>Insertable appliance to be loaded by hand and designed to burn solid fuels (indicated in instructions), whose function is to heat the space in which it is installed. Intermittent operation. For non-shared conduit.</p> <p>Aparelho encastrável de carga manual, para queimar combustíveis sólidos (indicado nas instruções), cuja função é aquecer o espaço no qual está instalado. Operação intermitente. Para conduíte não compartilhado.</p>	
<p align="center">EN13229:2001/A2:2004/AC:2007</p>	
Características esenciales, Caractéristiques essentielles, Caratteristiche essenziali, Essential features, Características essenciais	Prestaciones, Performance, Prestazione, Services, Desempenho
Reacción al fuego, Réaction au feu, Reazione al fuoco, Reaction to fire, Reação ao fogo	Cumple, Conforme, Conforme, Compliant, Em Conformidade
Distancia mínima de seguridad a materiales combustibles, Distance minimum aux matériaux combustibles, Distanza minima da materiali combustibili, Minimum distance from combustible material, Distância mínimo de materiais combustíveis	Izquierda, gauche, sinistra, left, esquerda: 400mm Derecha, droite, diritto, right, direito: 400mm Trasera, arrière, retro, back, traseira: 4300mm Delantera, avant, fronte, front, frente: 1600mm Encimera, dessus, sopra, above, acima: 800mm
Temperatura humos a potencia térmica nominal, Température des fumées, Temperatura fumi, Fume temperatura, Temperatura dos gases de combustão	245 °C
Emisión productos combustión, Emisión des produits de combustion, Emisión prodotti combustione, Combustión productos emissions, Emissões de produtos de combustão	Cumple, Conforme, Conforme, Compliant, Em Conformidade
Emisión, Emission, Emissione, Emissão, Emission, CO 13% O2	0,08 %
Emisión, Emission, Emissione, Emissão, Emission, CO 13% O2	1056 mg/Nm³
Emisión, Emission, Emissione, Emissão, Emission, NOx 13% O2	121 mg/Nm³
Emisión, Emission, Emissione, Emissão, Emission, OGC 13% O2	66 mg/Nm³
Emisión, Emission, Emissione, Emissão, Emission, PM 13% O2	25 mg/Nm³
Desprendimiento de sustancias peligrosas, Rejet de substances dangereuses, Rilascio di sostanze pericolose, Release of hazardous substances, Lançamento de substâncias perigosas	Cumple, Conforme, Conforme, Compliant, Em Conformidade
Temperatura superficial, Température de surface, Temperatura superficiale, Surface temperatura, Temperatura superficial	Cumple, Conforme, Conforme, Compliant, Em Conformidade
Seguridad eléctrica, Sécurité électrique, Sicurezza elettrica, Electrical safety, Segurança elétrica	Cumple, Conforme, Conforme, Compliant, Em Conformidade
Resistencia mecánica (para soportar una chimenea/un conducto de humos), Résistance mécanique (pour soutenir la cheminée), Resistenza mecánica (per supportare il camino), Mechanical strength (to support the fireplace), Resistência mecânica (para suportar a chaminé)	Cumple, Conforme, Conforme, Compliant, Em Conformidade
Potencia térmica ambiente, Puissance rendue au milieu, Potenza resa all'ambiente, Power output to the environment, Potência libertada no ambiente	13 kW
Potencia térmica agua, Puissance rendue à l'eau, Potenza ceduta all'acqua, Power transferred to wáter, Potência cedida à água	-
Rendimiento energético, Rendement, Rendimento, Efficiency, Atuação	79,5 %

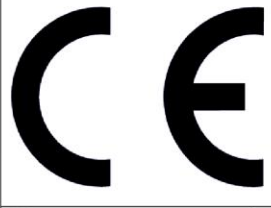
	LACUNZA KALOR GROUP S.A.L. Pol. Ind. Ibarrea 5A 31800 Alsasua (Navarra) (Spain)
09	Número, Nombre, Numero, Number, Número: CH-S-013
Marca, marque, marca, mark, marca: Lacunza Tipo, type, tipo, type, tipo: Insertable, Appareil insérable, Apparecchio a incasso, Insertable appliance, Aparelho encastrável Modelo, modèle, modello, model, modelo: ITACA120 ECO, ITACA120 ECO C/V, ITACA120 ECO V, ITACA120 ECO V C/V	Organismo notificado, Laboratoire notifié, Laboratorio notificado, Laboratory notified, Laboratorio notificado: SZU N° 1015
Aparato Tipo, Type d'appareil, Tipo di apparecchio, Apparatus Type, Tipo de aparelho: BE	
<p>Chimenea de carga manual, para quemar combustibles sólidos (indicado en instrucciones), cuya función es calentar el espacio en el que está instalada. Funcionamiento Intermitente. Para conducto humos no compartido.</p> <p>Appareil insérable qui se charge manuellement, conçu pour brûler des combustibles solides (indiqués dans le Manuel d'Instructions), dont la fonction est de chauffer l'espace où il est installé. Fonctionnement intermittent. Pour conduit non partagé.</p> <p>Apparecchio a incasso a carico manuale, per bruciare combustibili solidi (indicati nelle istruzioni), la cui funzione è riscaldare lo spazio in cui è installato. Funzionamento intermittente. Per condotto non condiviso.</p> <p>Insertable appliance to be loaded by hand and designed to burn solid fuels (indicated in instructions), whose function is to heat the space in which it is installed. Intermittent operation. For non-shared conduit.</p> <p>Aparelho encastrável de carga manual, para queimar combustíveis sólidos (indicado nas instruções), cuja função é aquecer o espaço no qual está instalado. Operação intermitente. Para conduíte não compartilhado.</p>	
<p align="center">EN13229:2001/A2:2004/AC:2007</p>	
Características esenciales, Caractéristiques essentielles, Caratteristiche essenziali, Essential features, Características essenciais	Prestaciones, Performance, Prestazione, Services, Desempenho
Reacción al fuego, Réaction au feu, Reazione al fuoco, Reaction to fire, Reação ao fogo	Cumple, Conforme, Conforme, Compliant, Em Conformidade
Distancia mínima de seguridad a materiales combustibles, Distance minimum aux matériaux combustibles, Dintanza minima da materiali combustibili, Minimum distance from combustible material, Distância mínimo de materiais combustíveis	Izquierda, gauche, sinistra, left, esquerda: 400mm Derecha, droite, diritto, right, direito: 400mm Trasera, arrière, retro, back, traseira: 4300mm Delantera, avant, fronte, front, frente: 1600mm Encimera, dessus, sopra, above, acima: 800mm
Temperatura humos a potencia térmica nominal, Température des fumées, Temperatura fumi, Fume temperatura, Temperatura dos gases de combustão	245 °C
Emisión productos combustión, Emisión des produits de combustion, Emisión prodotti combustione, Combustión productos emissions, Emissões de produtos de combustão	Cumple, Conforme, Conforme, Compliant, Em Conformidade
Emisión, Emission, Emissione, Emissão, Emission, CO 13% O2	0,08 %
Emisión, Emission, Emissione, Emissão, Emission, CO 13% O2	1056 mg/Nm³
Emisión, Emission, Emissione, Emissão, Emission, NOx 13% O2	87 mg/Nm³
Emisión, Emission, Emissione, Emissão, Emission, OGC 13% O2	66 mg/Nm³
Emisión, Emission, Emissione, Emissão, Emission, PM 13% O2	25 mg/Nm³
Desprendimiento de sustancias peligrosas, Rejet de substances dangereuses, Rilascio di sostanze pericolose, Release of hazardous substances, Lançamento de substâncias perigosas	Cumple, Conforme, Conforme, Compliant, Em Conformidade
Temperatura superficial, Température de surface, Temperatura superficiale, Surface temperatura, Temperatura superficial	Cumple, Conforme, Conforme, Compliant, Em Conformidade
Seguridad eléctrica, Sécurité électrique, Sicurezza elettrica, Electrical safety, Segurança elétrica	Cumple, Conforme, Conforme, Compliant, Em Conformidade
Resistencia mecánica (para soportar una chimenea/un conducto de humos), Résistance mécanique (pour soutenir la cheminée), Resistenza mecánica (per supportare il camino), Mechanical strength (to support the fireplace), Resistência mecânica (para suportar a chaminé)	Cumple, Conforme, Conforme, Compliant, Em Conformidade
Potencia térmica ambiente, Puissance rendue au milieu, Potenza resa all'ambiente, Power output to the environment, Potência libertada no ambiente	14 kW
Potencia térmica agua, Puissance rendue à l'eau, Potenza ceduta all'acqua, Power transferred to wáter, Potência cedida à água	-
Rendimiento energético, Rendement, Rendimento, Efficiency, Atuação	79,5 %

LACUNZA KALOR GROUP S.A.L

Pol. Ind. Ibarrea 5A

31800 Alsasua (Navarra) Spain

Tel.: (00 34) 948 56 35 11

Fax.: (00 34) 948 56 35 05

e-mail: comercial@lacunza.net

Website: www.lacunza.net

EDITION: 02

