

Clásica 5T Clásica 7T Clásica 8T

Instruction Book

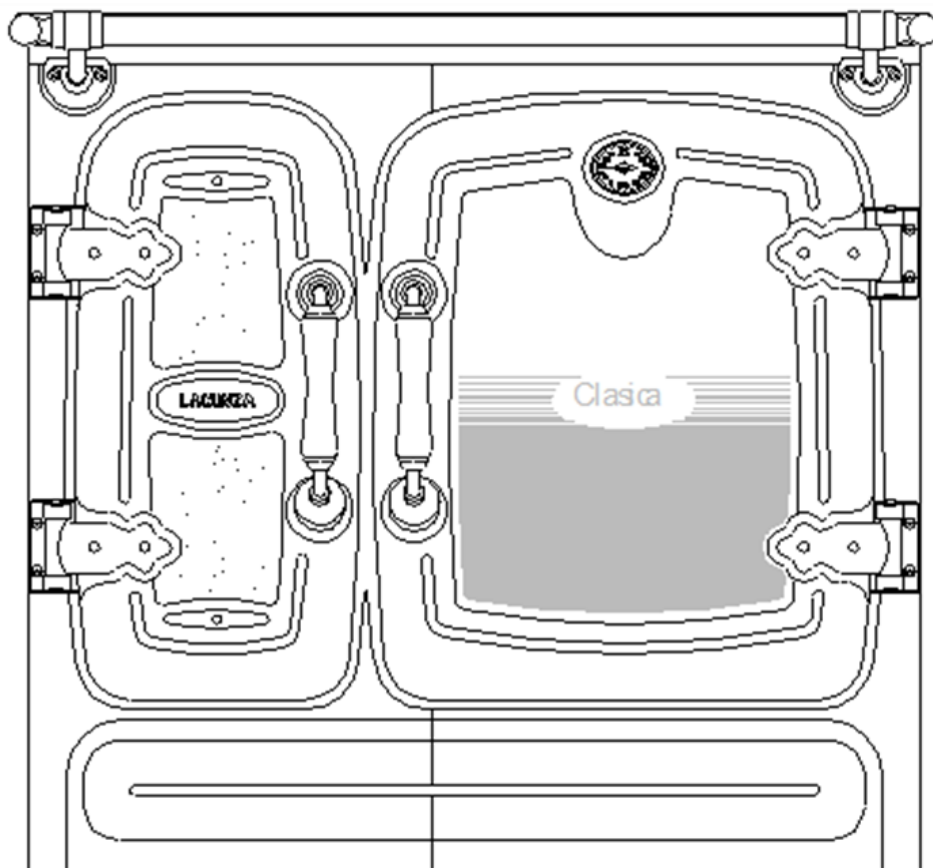

Lacunza congratulates you on your choice.
Certified under ISO 9001, Lacunza guarantees the quality of its appliances and undertakes to meet the needs of its customers.

Confident of the know-how afforded by more than 50 years' experience, Lacunza uses advanced technologies in the design and manufacture of its entire range of appliances. This document will help you install and use your appliance in optimum conditions for your comfort and safety.

CONTENTS

1. PRESENTATION OF THE APPLIANCE	3
1.1. General characteristics.....	3
2. INSTRUCTIONS FOR THE INSTALLER.....	7
2.1. Warning to installers.....	7
2.2. Room for installation.....	7
2.2.1. Ventilation of the room.....	7
2.2.2. Location of the appliance in the room.....	8
2.3. Installation of the appliance.....	8
2.3.1. Floor.....	8
2.3.2. Safety distances.....	8
2.3.3. Checks before lighting for the first time.....	8
2.3.4. Height adjustment and levelling the appliance.....	8
2.3.5. Casing.....	8
2.3.6. Connection to the flue.....	9
2.4. Chimney flue.....	10
2.4.1. Type of flue.....	10
2.4.2. Chimney crown.....	10
3. INSTRUCTIONS OF USE	12
3.1. Fuel.....	12
3.2. Description of the parts of the appliance	13
3.2.1. Operating components.....	13
3.3. Lighting.....	14
3.4. Loading fuel.....	14
3.5. Operation	14
3.6. Removing ash	15
3.7. Instructions for cooking	15
3.7.1. Cooking in the oven.....	15
3.7.2. Cooking on the top surface.....	15
3.7.2.1. Glass-ceramic Top Surface.....	16
4. MAINTENANCE AND IMPORTANT ADVICE.....	17
4.1. Maintenance of the appliance.....	17



4.1.1. Visible enamelled parts.....	17
4.1.2. Top surface.....	17
4.1.3. Firebox.....	17
4.1.4. Inside the appliance.....	17
4.1.5. Flue socket.....	17
4.1.6. Chrome parts.....	18
4.1.7. Brass parts.....	18
4.1.8. Enamelled-steel parts.....	18
4.1.9. Oven.....	18
4.2. Maintenance of the chimney flue.....	19
4.3. Important advice.....	19
5. TROUBLESHOOTING.....	20
6. BASIC BREAKDOWNS.....	21
7. PRODUCT RECYCLING.....	23
8. DECLARATION OF PERFORMANCE.....	24
9. CE MARK.....	30

1. PRESENTATION OF THE APPLIANCE

For optimum operation of the appliance, we advise you to read this manual carefully before switching on the appliance for the first time. In case of problems or concerns, we urge you to contact your dealer, who will cooperate with you.

In order to improve the product, the manufacturer reserves the right to make changes without notice by updating this document.

This appliance is designed to burn wood in absolutely safe conditions.

WARNING: Faulty installation may have serious consequences.

Installation and all necessary regular maintenance operations must be performed by an authorized installer in full accordance with the specifications set out in the legislation applicable in each country and this instruction book.

1.1. General characteristics

	Unit	Clásica 5T	Clásica 7T	Clásica 8T	
Operating appliance	-	Intermittent	Intermittent	Intermittent	
Appliance classification	-	Type B	Type B	Type B	
Preferred fuel	-	Wood logs (Humidity<25%)	Wood logs (Humidity<25%)	Wood logs (Humidity<25%)	
Indirect heating functionality	-	NO	NO	NO	
Values at Nominal Output	Nominal output to atmosphere (Direct) (P_{nom})	kW	10	11	12
	Efficiency at P_{nom} (η_{nom})	%	85	85	85,3
	CO emission at 13% O ₂ at P_{nom} (CO_{nom})	mg/m ³	807	969	969
	NO _x emission at 13% O ₂ at P_{nom} (NO_{xnom})	mg/m ³	159	174	174
	OGC emission at 13% O ₂ at P_{nom} (OGC_{nom})	mg/m ³	82	82	75
	PM emission at 13% O ₂ at P_{nom} (PM_{nom})	mg/m ³	31	31	31
	Optimum flue draught at P_{nom} (p_{nom})	Pa	12	12	12
	Gas temperature of flue at P_{nom} (T_{nom})	°C	175	175	175
	Gas temperature on the flue socket flange at P_{nom}	°C	191	191	175
	Log load frequency at P_{nom}	h	1	1	1
	Gas mass flow at P_{nom}	g/s	11,1	14,7	14,7
	Wood consumption (beech) at P_{nom}	kg/h	2,9	3,2	3,5
	Chimney temperature class	-	T400	T400	T400
	Dimensions of the firebox				
Width	mm	200	270	270	
Depth	mm	440	470	470	
Useful height	mm	340	340	340	
Maximum length of the logs	cm	43	47	47	
Volume heated (45W/m ³) at P_{nom}	m ³	222	244	267	
Useful dimensions of the oven					
Width	mm	370	420	500	
Depth	mm	430	430	430	
Useful height	mm	420	400	400	
Capacity of the ashpit	L	5	5	5	
Weight	kg	180	220	237	
Flue socket diameter (d_{out})	mm	150	150	150	
Type of heat output/room temperature control	Single stage heat output, no room temperature control				

Energy efficiency class	-	A+	A+	A+
Energy efficiency index (EEI)	-	113	113	114
Seasonal Energy Efficiency of space heating (η_s)	%	74,5	74,5	75,3

Note: The values indicated in the above table are based on tests performed in accordance with UNE-EN 12815 with logs with no more than 18% humidity and pressure conditions as indicated in each case.

Warning: this appliance is designed and prepared to work with the types of fuel, degree of humidity of the fuel, fuel loads, fuel load frequencies, flue draught and system of installation indicated in this Instruction Book. Failure to respect these conditions may lead to problems with the appliance (deterioration, shorter useful life, etc.) which are not covered by the Lacunza warranty.

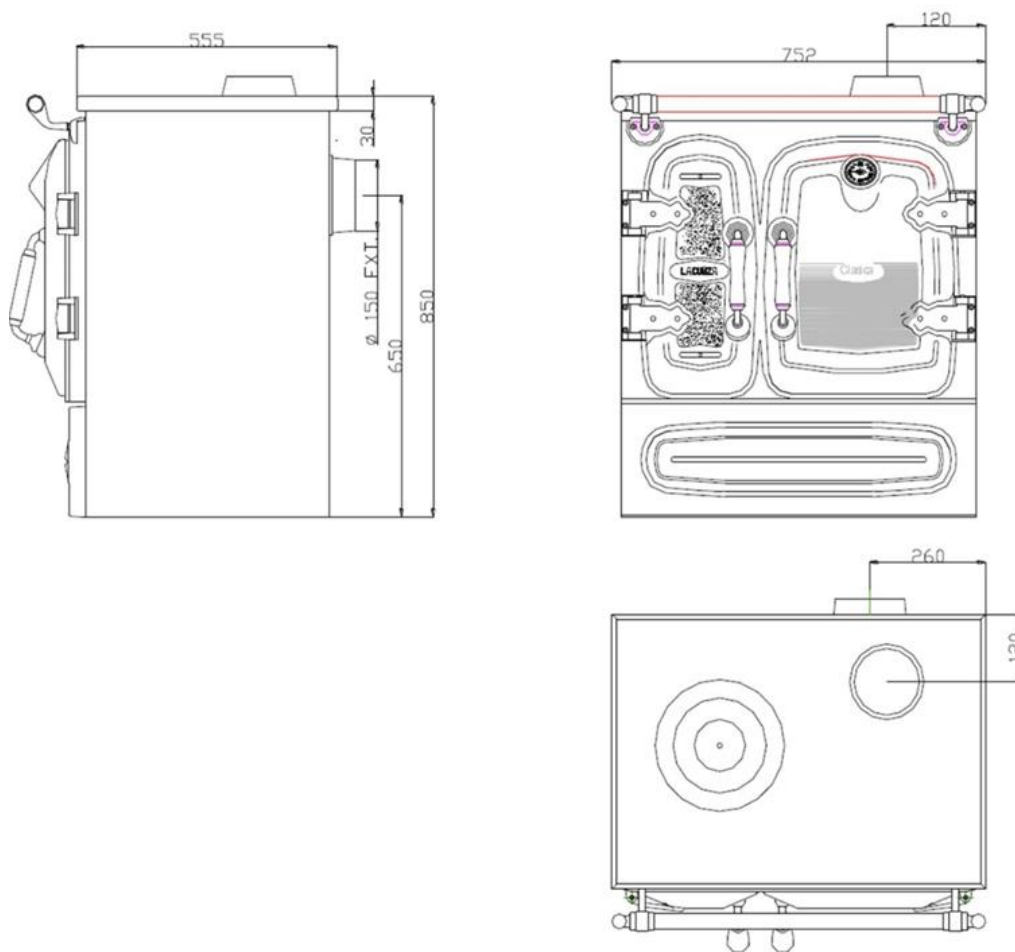

Figure No.1 - Dimensions of the Clásica 5T appliance in mm

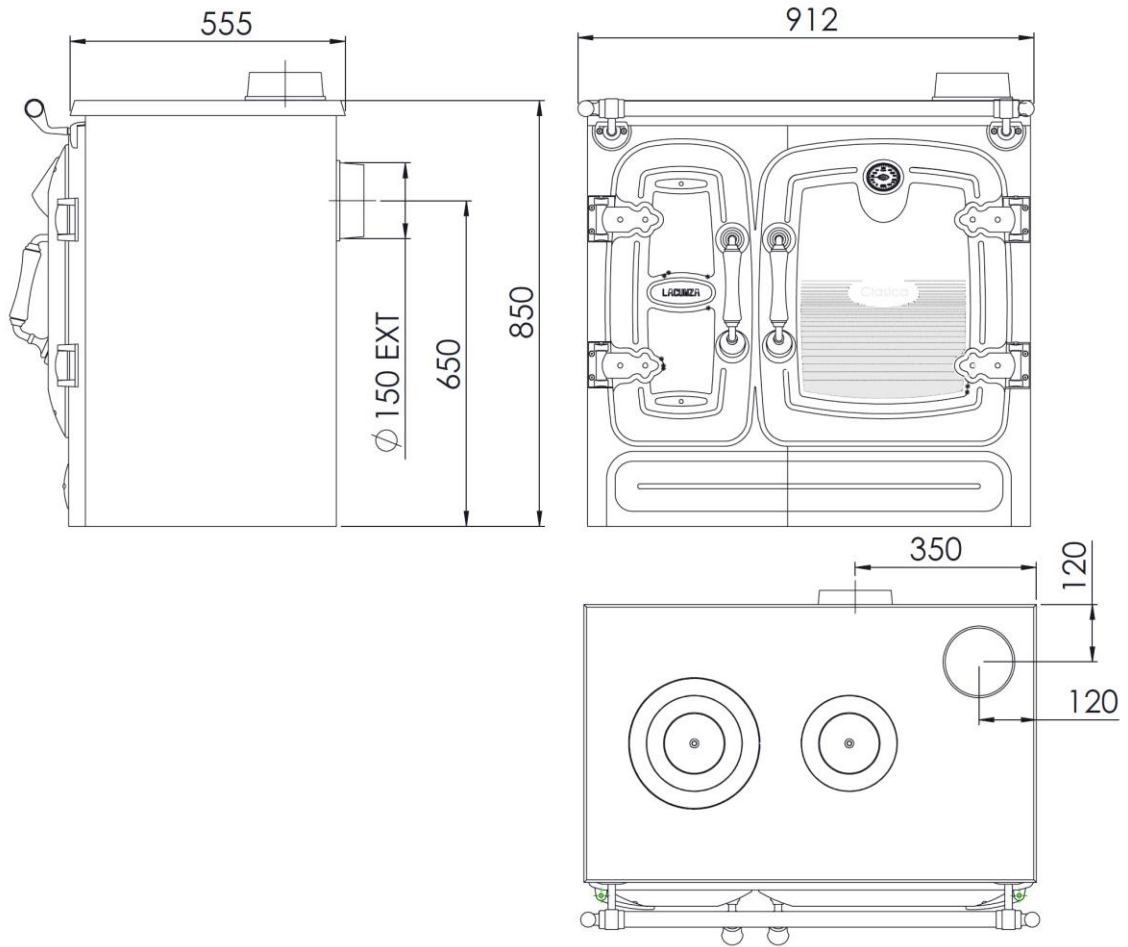

Figure No.2 - Dimensions of the Clásica 7T appliance in mm

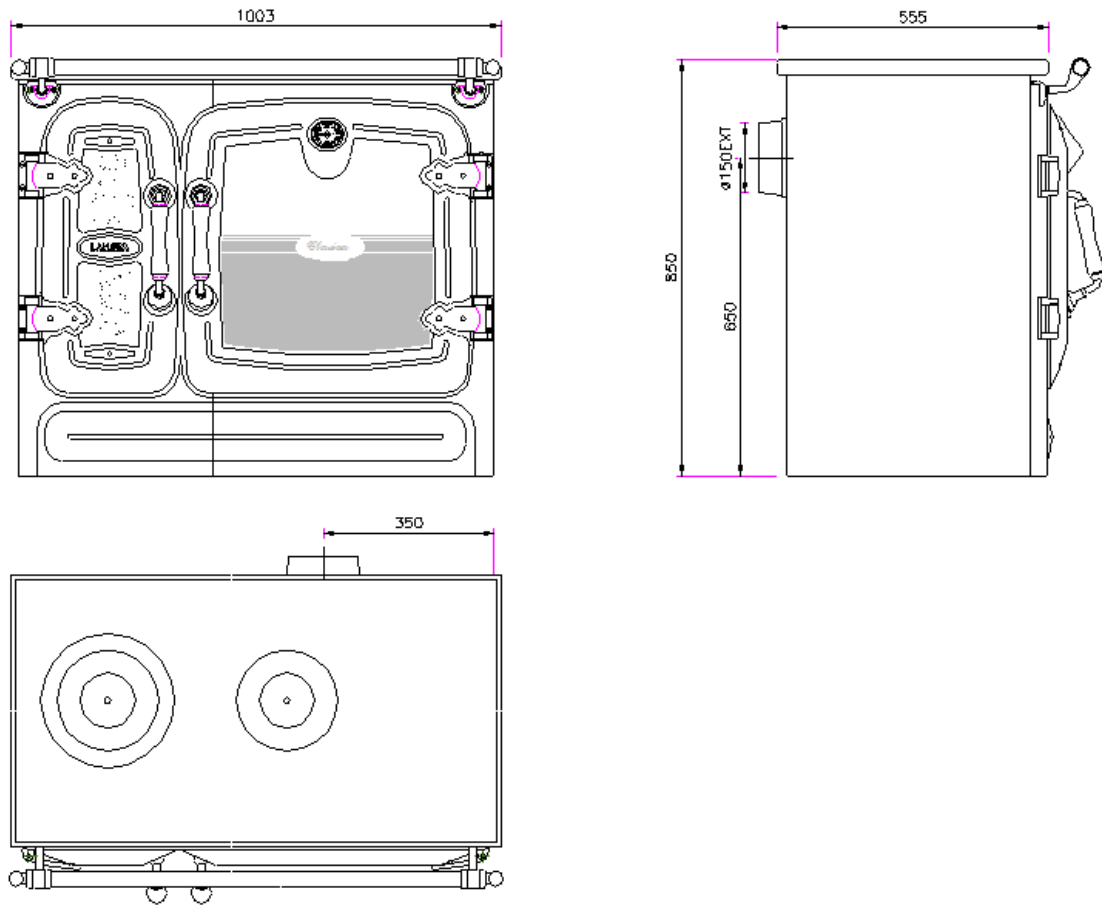

Figure No.3 - Dimensions of the Clásica 8T appliance in mm

2. INSTRUCTIONS FOR THE INSTALLER

2.1. Warning to installers

All local and national regulations, including all those referring to national and European standards, must be observed when installing the appliance.

Installation of the appliance must be performed by an authorised installer.

An incorrectly installed appliance may lead to serious incidents (fires, creation of harmful gases, deterioration of nearby fixtures, etc.).

Lacunza's liability is limited to the supply of the material and does not include installation of the appliance.

2.2. Room for installation

2.2.1. Ventilation of the room

The appliance needs to consume oxygen (air) in order to work properly. Ensure a suitable air supply in the room in which the appliance is fitted. This quantity of oxygen is additional to the oxygen that we need in order to breathe (air renewal).

In order to ensure the high quality of the air you breathe and to avoid potential accidents resulting from high concentrations of the gases produced by combustion (mainly carbon dioxide and carbon monoxide), it is absolutely crucial to ensure the suitable renewal of the air in the room in which the appliance is fitted.

The room must always have at least two permanent grilles or openings to the exterior in order to renew the air (one for intake and the other for extraction).

For the installation of its appliances, Lacunza recommends an additional section for these openings. One of these two grilles must be situated high up in the room (at less than 30 cm from the ceiling)

and the other one low down (at less than 30 cm from the floor). Both grilles must open outdoors in order to renew the air in the room with fresh air.

The air inlet grilles must be positioned so that they cannot be blocked or closed accidentally.

The minimum section that each of these grilles must have depends on the nominal output of the appliance in accordance with the following table:

Output of the appliance (kW)	Minimum additional section of each of the grilles (cm ²)
$P \leq 10$ kW	70
$10 < P \leq 15$	90
$15 < P \leq 20$	120
$20 < P \leq 25$	150
$25 < P \leq 30$	180
$30 < P \leq 35$	210
$P > 35$	240

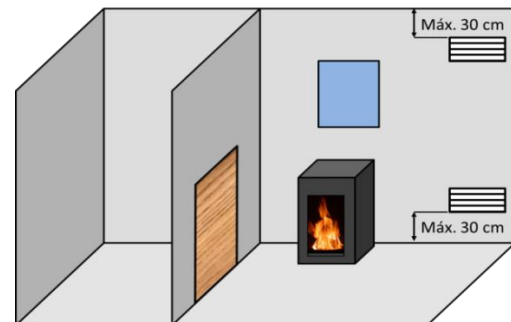

Figure No.4 - Guideline indications for ventilation grilles

The appliance must always be used with the door(s) closed.

In rooms equipped with Controlled Mechanical Ventilation, the system extracts and renews the ambient air; in such cases, the room is at slightly low pressure and it is necessary to install a non-closable outside-air inlet with a section of at least 90 cm².

2.2.2. Location of the appliance in the room

Choose a location in the room which favours good hot-air distribution by convection and radiation.

2.3. Installation of the appliance

2.3.1. Floor

Make sure that the base can withstand the total constructed weight of the appliance and its casing.

The apparatus should not be placed on combustible material.

2.3.2. Safety distances

Be sure to respect the appliance installation distances from **combustible materials**.

	Distance to combustible materials (mm)
From the right-hand side	200
From the left-hand side	200
From the rear	200
From the front	200
From the top	800

Bear in mind that it may even be necessary to protect non-combustible material in order to prevent breakage, deformation, etc., as a result of overheating if the non-combustible material is not designed to withstand high temperatures. A safety distance of 25 cm must be left to isolating materials of type M0.

2.3.3. Checks before lighting for the first time

- Make sure that the glass/es is/are not broken or damaged.
- Make sure that the flueway is not obstructed with packing or loose parts.

- Make sure that the airtight joints on the flue circuit are in perfect condition.
- Make sure that the doors close properly.
- Make sure that all moving parts are fitted in place.

2.3.4. Height adjustment and levelling the appliance

The appliance must be perfectly level, horizontally and vertically, both at the front and on the sides (use a spirit level).

2.3.5. Casing

Make sure that the material around the appliance is not flammable or likely to deteriorate as a result of heat (wallpaper, carpet, plastic-based casing, Silestone, etc.).

If the top surface is surrounded by building material (marble, brick, etc.) as part of the kitchen stove installation process, leave a gap of at least 4mm to allow the top surface to dilate.

Secure the enamelled double sides to the kitchen stove using the screws provided.

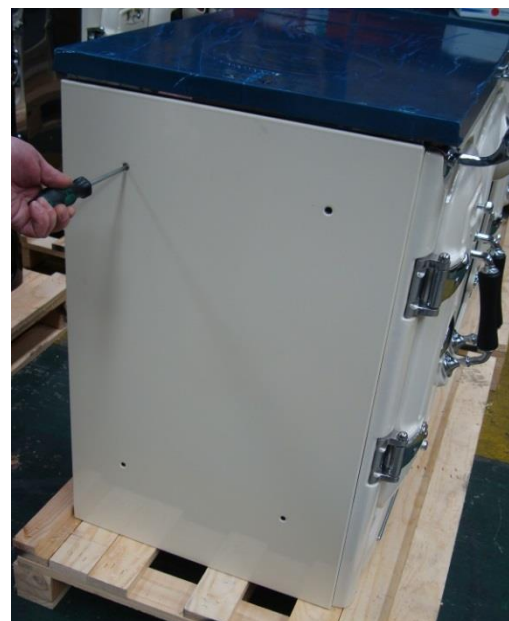

Figure No.5 - Securing the double sides

2.3.6. Connection to the flue

The appliance must be connected to the chimney flue using special piping designed to resist the products of combustion (e.g. stainless steel, enamelled steel, etc.).

To connect the flue to the socket flange, insert the piping inside the flange and seal the joint with fire sealant or fire cement to make it completely airtight.

The installer must ensure that the pipe connected to the appliance is well secured and there is no chance of it coming free from its housing (e.g. as a result of dilatation due to temperature, etc.).

If you have a cast-iron top surface with a flue socket on top, the flue can be fitted either on top or at the rear of the appliance.

In order to fit the flue socket at the rear of the appliance, remove galvanised part and part A, and secure flue socket flange C with two nuts and bolts. Fit cast-iron cover B on the top surface.

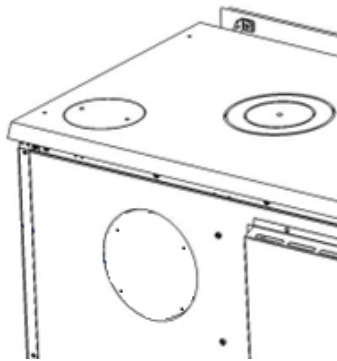

Figure No.6 - Remove the galvanised part

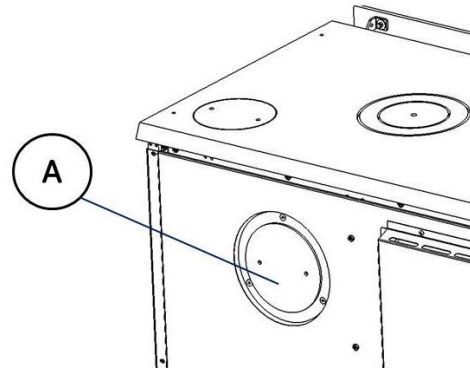

Figure No.7 - Remove the part A

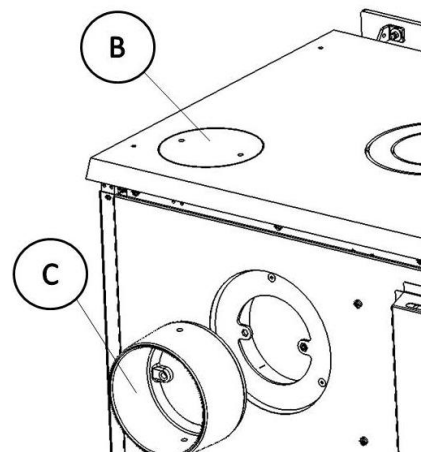

Figure No.8 - Diagram for rear flue socket

In order to fit the flue socket on top of the appliance, leave galvanised part and part A where they are (factory position), part B must be removed and secure flue socket flange D on the top surface with two nuts and bolts.

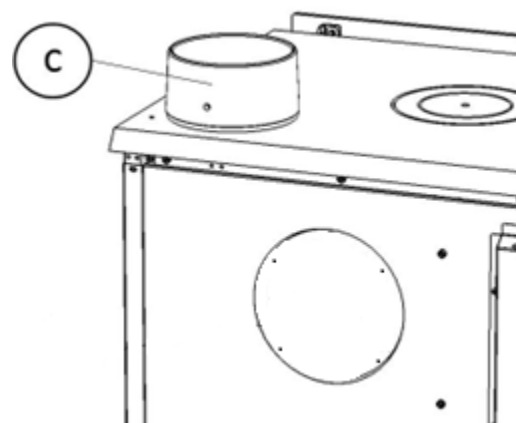

Figure No.9 - Diagram for top flue socket

2.4. Chimney flue

The chimney flue must comply with present standards on the installation of chimneys.

In rooms equipped with Controlled Mechanical Ventilation, the ventilation outlet must never be connected to the flue.

The appliance must always have its own chimney flue, never sharing a chimney flue with another appliance.

2.4.1. Type of flue

The flue must be made of special material designed to resist the products of combustion (e.g. stainless steel, enamelled steel, etc.).

Non-central-heating appliances (without back boiler) require an insulated, double-sleeve flue only on those sections that run outdoors or through cold areas. Single piping can be used inside the building, the heat of the gases serving to heat rooms, insulating only those sections where excess temperature may cause damage.

If the chimney is constructed, then it is necessary to pipe and insulate it to ensure correct updraught.

The diameter of the pipe must be the same as the diameter of the flue socket on the appliance over its entire length in order to ensure correct operation.

The flue must prevent the entry of rainwater.

The flue must be clean and airtight over its entire length.

The flue must be at least 6m tall and the chimney cap must not hinder the free release of gases.

If the flue tends to suffer from downdraught, then it is necessary to fit an effective anti-downdraught cowl, a static

cowl or a smoke extraction fan, or reshape the chimney.

Never make 90° bends, except the one on kitchen-stove outlets, due to the great loss of draught they cause, and reduce 45° bends down to an absolute minimum. Each 45° bend is equivalent to a 0.5m reduction in flue length. Horizontal flue sections should not be installed because they cut updraught a great deal.

The appliance is designed to operate under controlled draught conditions. The appliance must operate at a chimney draught of between 12Pa and 15Pa. To ensure this draught, an automatic draught moderator must be installed in the flue. Uncontrolled draught operation can lead to quick damage of the appliance, which will not be covered by the warranty.

The flue must not rest its weight on the appliance, as this could damage the worktop.

Bear in mind that high temperatures may be reached in the flue, meaning that it is essential that insulation be enhanced in sections in which combustible material is present (wooden beams, furniture, etc.). It may even be necessary to protect non-combustible material in order to prevent breakage, deformation, etc., as a result of overheating if the material is not designed to withstand high temperatures.

It must be possible to clean the entire flue, no sections being left inaccessible for cleaning purposes.

2.4.2. Chimney crown

The upper end of the chimney must clear the roof, the roof ridge or any obstacle located on the roof by at least 1m.

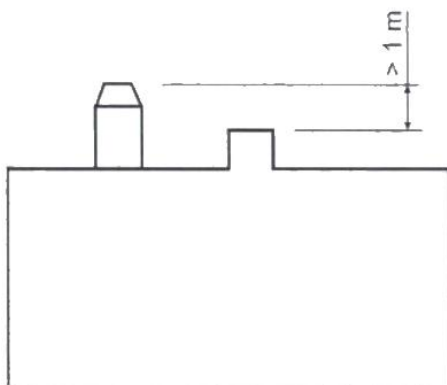
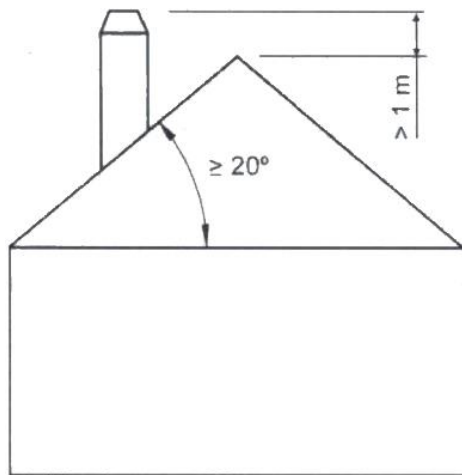
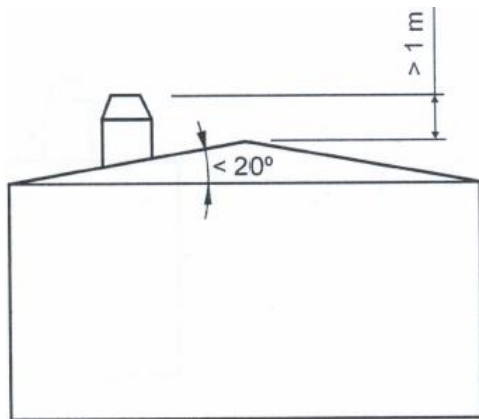

Figure No.10 - Distances between chimney crown and roof ridge

The chimney crown must clear the highest point of any neighbouring building or obstacle located within a 10m radius of the chimney outlet by more than 1m.

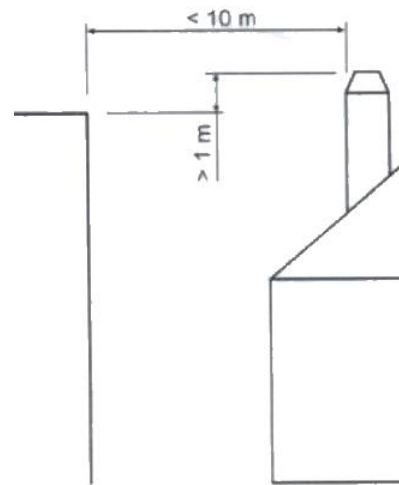

Figure No.11 - Distances between the chimney crown and objects within a 10m radius

The chimney crown must clear any neighbouring building or obstacle located within a radius of 10m to 20m from the chimney outlet.

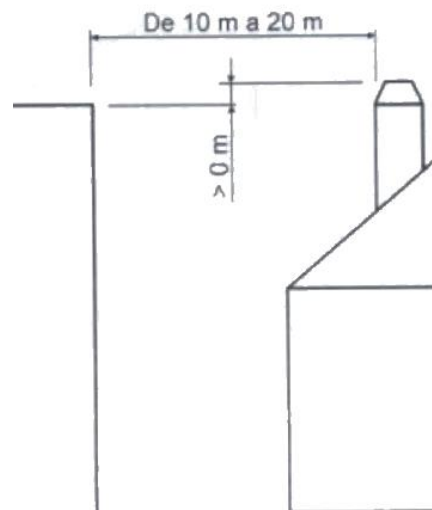

Figure No.12 - Distances between the chimney crown and objects within a radius of between 10 and 20m

3. INSTRUCTIONS OF USE

The manufacturer accepts no liability whatsoever for damage caused to parts as a result of the improper use of non-recommended fuels, modifications made to the appliance or how it is installed. **Only use original replacement parts.**

All local and national regulations, including those referring to national and European standards, must be observed when using the appliance.

Heat is diffused by radiation and convection via the front and exterior of the appliance.

3.1. Fuel

This appliance must not be used as an incinerator. Do not use non-recommended fuels.

- Use dry logs (max. 16% humidity), cut at least 2 years ago, clean of resin and stored in a sheltered, ventilated place.
- Use hard woods with high calorie values and good ember production.
- Large logs should be cut to useable lengths before being stored. The logs should have a maximum diameter of 150mm.
- Finely-chopped wood produces greater heat output, but also burns more quickly.

Optimum fuels:

- Beech.

Other fuels:

- Oak, chestnut, ash, maple, birch, elm, etc.
- Pine and eucalyptus logs are low density and produce very long flames, and may cause the parts of the appliance to wear out more quickly than normal.

- Resinous wood may mean that the appliance and the flue need to be cleaned more often.

Non-permitted fuels:

- All types of coal and liquid fuel.
- “Green wood”. Green or damp wood reduces the performance of the appliance and leads to soot and tar build-up on the inner walls of the flue, obstructing it.
- “Recovered wood”. The burning of treated woods (railway sleepers, telegraph posts, plywood, fibreboard, pallets, etc.) quickly blocks the system (soot and tar build-up), harms the environment (pollution, smells) and may lead to deformation of the firebox due to overheating.
- All materials which are not wood (plastic, spray cans, etc.).
- Never use gasoline, gasoline-type lamp fuel, paraffin, charcoal lighter fluid, ethyl alcohol or similar liquids to ignite or rekindle a fire in the equipment. Keep all such liquids away from the equipment while it is in use.

Green and reprocessed wood may cause chimney fires.

The graph below shows how the humidity of firewood affects its heat output:

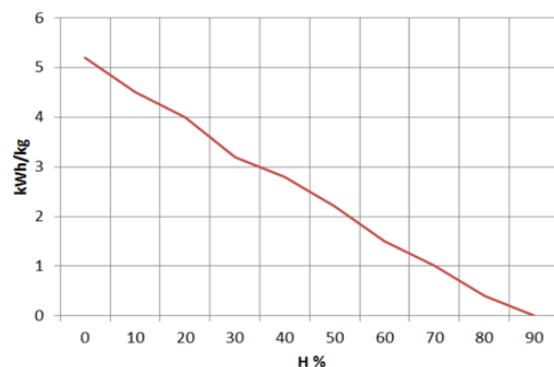

Figure No.13 - Relationship between firewood humidity and heat output

3.2. Description of the parts of the appliance

3.2.1. Operating components

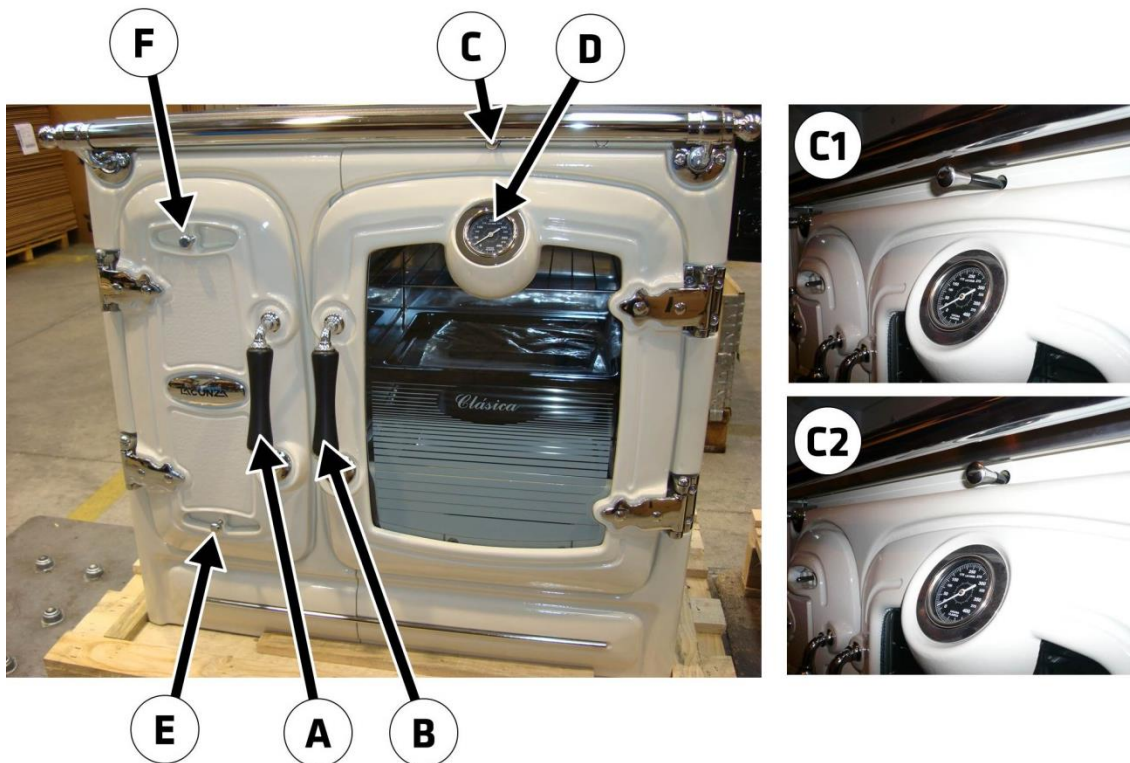

Figure No.14 - Operating components on the appliance

- A: Firebox door handle
- B: Oven door handle
- C: Direct draught rod
 - C1 open
 - C2 closed
- E: Oven thermometer
- F: Primary air intake
 - F1 open (turn clockwise)
 - F2 closed (turn anti-clockwise)
- G: Secondary air intake
 - G1 open (turn clockwise)
 - G2 closed (turn anti-clockwise)

3.3. Lighting

Use of the appliance in warm weather (warm days, early hours of the afternoon on sunny days) may lead to lighting and updraught problems.

Certain weather conditions, such as fog, ice, humidity entering the flue, etc., may hinder sufficient updraught in the flue and lead to suffocation.

Proceed as follows in order to light the appliance satisfactorily:

- Open the firebox door(s) and open all the firebox air-intake inlets to the full.
- Open the direct draught rod for about 15 minutes until the chimney flue warms up.
- Place paper or a firelighter and some wood chips in the firebox.
- Light the paper or firelighter.
- Leave the door slightly ajar, the width of two or three fingers, for about 15 minutes.
- The first time the appliance is lit, the fire should be gentle to allow the parts of the appliance to dilate and dry.

Important: The first time it is lit up, the appliance may give off smoke and strange smells. This is not a cause for concern. Open an outdoor window to ventilate the room during the first few hours of operation.

If you notice water around the appliance, this is produced by the condensation of the moisture in the wood on lighting the fire. This condensation will no longer appear when the appliance has been lit three or four times and has adapted to its flue. If it does not disappear, then check the flue draught (length and diameter of the flue, flue

insulation, airtightness) and the humidity of the wood used.

If the condensation comes into contact with the enamel, wipe it off and dry with a cloth straight away to prevent any possible loss of shine.

3.4. Loading fuel

In order to load firewood, open the firebox door gently, preventing the sudden entry of air to the firebox so that smoke does not enter the room that the appliance is installed in. Firewood can also be loaded through the ring holes on cast-iron top surfaces.

Perform this operation with the glove to prevent burns to the hands.

The maximum height of the load shall be approximately one third of the height of the firebox.

The minimum interval between loads for nominal heat output is 60 minutes.

Always load with the nominal amount (see table in section 1.1).

For minimum burning (e.g. at night), use thicker logs.

When the firebox is loaded, close the door.

3.5. Operation

The appliance should be operated with the door(s) closed and the direct draught rod closed.

For safety reasons, never close all the appliance's combustion-air intakes.

Primary-air intake

By opening this inlet, air enters the firebox via the firebox grille.

Secondary-air intake

By opening this inlet, air enters the firebox via the top of the firebox door.

IMPORTANT: Keeping the secondary-air intake open helps keep the door glass cleaner for longer.

Double-combustion air intake

This appliance has the double combustion air inlet through the holes at the back of the firebox free and not adjustable.

Air enters the combustion flame, making for more efficient and less polluting combustion because post-combustion takes place, burning the particles which were not burned in the first combustion. This increases the performance of the appliance and reduces emissions.

In order to obtain maximum output, open all the air intakes to the firebox and in order to obtain minimum output, tend towards closing them. For normal use, we recommend you close the Primary Intake and leave the Secondary 22% open.

In class B or BE appliances (without combustion air ducting from the street), when the appliance is not in use, the appliance-flue duct assembly may represent a heat leakage route to the street. When the appliance is not in use, it is advisable to leave the air inlet registers to the combustion chamber closed to minimise these energy losses.

3.6. Removing ash

Following sustained use of the appliance, it is necessary to remove the ash from the firebox. Remove the ashpit box when cold or using something to prevent yourself from getting burned (glove).

Never throw hot embers into the rubbish.

Access the ashpit by opening the door on the appliance.

3.7. Instructions for cooking

The appliance allows you to cook on the top surface and in the oven.

3.7.1. Cooking in the oven

Follow the indications given in the following table:

	Min. Output	Max. Output
Direct draught	Closed	Closed
Primary intake	Closed	Open
Secondary intake	Closed	Open

The oven contains an oven tray and an oven rack.

The oven thermometer gives an approximate reading of the temperature inside the oven. While the appliance is warming up, which may take two hours, the thermometer indicates a temperature lower than the real temperature inside the oven (due to the thermal inertia of the cast iron).

3.7.2. Cooking on the top surface

Follow the indications given in the following table:

	Min. Output	Max. Output
Direct draught	Closed	Closed
Primary intake	Closed	Open
Secondary intake	Closed	Open

The best area of the top surface for cooking is the over the stove firebox. The

area of the top surface over the oven should be used to keep food warm.

3.7.2.1. Glass-ceramic Top Surface

Never place aluminium receptacles on the glass-ceramic top surface when hot. Likewise, never place aluminium foil or plastic, or pour sugar on the surface; they may become permanently incrustated in the glass.

Earthenware pots will scratch the glass.

If you lift the glass, you will discover enamelled cast-iron protective supports. You can cook on top of these but bear in mind the indications given in the Maintenance section.

How to lift/lower the glass-ceramic top surface

In order to lift the glass-ceramic surface and cook on the cast-iron protective supports, insert the hook supplied with the stove in the cylindrical orifice and move gently as shown in the images.



Figure No.15 - Hook inserted in the cylindrical orifice



Figure No.16 - Lifting with the hook

When you reach the full-open position, remove the hook from the orifice and leave to one side.



Figure No.17 - Glass-ceramic top surface resting at its full-open position

In order to lower the glass-ceramic top surface back to its original position, repeat the process in reverse order. Move gently at all times.

When you have finished using the protective supports, Lacunza recommends that you always return the glass-ceramic top surface to its original position (horizontal).

The glass-ceramic top surface must always be lifted/lowered when cold.

4. MAINTENANCE AND IMPORTANT ADVICE

4.1. Maintenance of the appliance

The appliance, the flue connector piping and the flue must be cleaned regularly, particularly following long periods without use.

4.1.1. Visible enamelled parts

The parts on the front of the kitchen stove are made of enamelled cast iron. Use a slightly damp cloth (or cloth with neutral soap) to clean the enamel and dry immediately (always when cold). Do not use metal scouring pads, abrasive, corrosive, chlorine-based or acid-based products to clean the enamelled parts; they could damage the enamel.

If water condenses or accidentally splashes on the appliance, clean the parts affected before they dry; otherwise, the colour of the enamel may be affected.

Be particularly careful to avoid spilling acid or alkaline products (tomato sauce, lemon juice, vinegar, ceramic hob cleaner, etc.) on the enamelled surfaces of the kitchen stove; they may damage the enamel coating.

4.1.2. Top surface

Glass-ceramic Top Surface

Use a damp cloth soaked in soap or special stainless-steel cleaning products to clean the stainless-steel trim around the ceramic.

Do not use metal scouring pads or abrasive sponges to clean the glass ceramic; they may scratch the surface. Use a scraper and special glass-ceramic cleaning products available on the market.

Enamelled protection

Maintain according to the instructions given for Visible enamelled parts (front of

the kitchen stove). Due to their position and function, however, these parts are subject to a great deal of wear and it is practically impossible to keep them in a good state.

Cast-iron top surface

Use special sandpaper and specific products to clean and maintain.

4.1.3. Firebox

Clean the firebox area of ash, etc.

4.1.4. Inside the appliance

To access the inside of the stove, lift the glass-ceramic surface and remove the protective supports. With a cast-iron top surface, you can access the inside through the ring holes or unscrew the top surface. You can then clean the oven area and the gas passage between the oven and the right-hand side.

Clean the firebox area of ash.

4.1.5. Flue socket

The flue socket area must be kept clean at all times for the appliance to work properly.

It must be cleaned as often as required. How often it is cleaned depends on how much the appliance is used and the type of fuel employed.

On kitchen stoves with a top flue socket, the flue socket is accessed by lifting the first section of piping. On kitchen stoves with a rear flue socket, the socket elbow-flange is accessed via the gap behind the oven. In these cases, we highly recommend that an access cover be fitted on the first section of the flue in order to clean the flue socket.

If the oven has a hatch at the back, use this as an access to clean the flue socket.

In order to gain access for cleaning purposes, it is necessary to unscrew the four screws from the back of the oven and

remove the plate. When you finish cleaning, replace the cover by screwing the 4 screws tight.



Figure No.18 - Access to the screws to remove the hatch cover

This operation must always be performed when the appliance is cold.

When the flue socket has been cleaned, gather up the soot accumulated at the bottom of the oven and extract it via the hatch located beneath the oven.



Figure No.19 - Accesses via which to clean the flue socket



4.1.6. Chrome parts

Use a damp cloth with neutral soap to clean the chrome parts and dry immediately. Do not use scouring pads, abrasive products, stripper or acid-based products; they could damage the chrome plating. Moisture can damage chrome.

4.1.7. Brass parts

Use special brass cleaning products available on the market to clean the brass parts.

4.1.8. Enamelled-steel parts

Use a damp cloth with neutral soap to clean the enamelled-steel parts and dry immediately. Do not use abrasive, corrosive, chlorine-based or acid-based products to clean the enamelled-steel parts; they could damage the enamel.

4.1.9. Oven

Use a slightly damp cloth (or cloth with neutral soap) to clean the oven and dry immediately. Stainless-steel ovens may turn yellowish as a result of heat. Do not use abrasive, corrosive, chlorine-based or acid-based products; they could damage the enamel.

Be particularly careful to avoid spilling acid or alkaline products (tomato sauce, lemon juice, vinegar, ceramic hob cleaner, etc.) on the enamelled surfaces of the kitchen stove; they may damage the enamel coating.

4.2. Maintenance of the chimney flue

VERY IMPORTANT: In order to avoid incidents (chimney fires, etc.), it is necessary to perform maintenance and cleaning operations on a regular basis; if the appliance is used often, then the chimney and the flue connector piping must be swept several times a year.

In the event of fire in the chimney, close the flue draught, close doors and windows, remove embers from the firebox, block the connection hole with damp cloths and call the fire brigade.

4.3. Important advice

Lacunza recommends that only Lacunza-authorized replacement parts be used.

Lacunza accepts no liability for any modification to the product which it has not authorized.





This appliance is a heat-producing appliance and contact may lead to burns.

This appliance may remain HOT for a period of time after it has gone out. **MAKE SURE THAT SMALL CHILDREN DO NOT GO NEAR IT.**

5. TROUBLESHOOTING



This symbol means that a qualified professional should be called to perform the operation.

Problem	Probable causes		Solution
The fire does not light properly The fire does not stay alight	Green or damp wood		Use hard woods, cut at least 2 years ago and stored in a sheltered, ventilated place
	The logs are too large		Use crumpled paper or firelighters and dry wood chips to light the fire. Use split logs to keep the fire going
	Poor-quality wood		Use hard woods which produce heat and embers (chestnut, ash, maple, birch, elm, beech, etc.)
	Insufficient primary air		Open the primary- and secondary-air intakes completely, or even open the door slightly. Open the outdoor-air inlet grille
	Insufficient updraught		Check that the draught is not blocked. De-soot if necessary. Check that the flue is in perfect condition (airtight, insulated, dry, etc.)
The fire flames up too much	Excessive primary air		Close the primary- and secondary-air intakes partially or totally
	Excessive updraught		Install a draught damper
Smoke given off on lighting	Poor-quality wood		Do not continually burn chips, carpentry scraps (plywood, pallets, etc.)
	Cold flue		Heat up the flue by burning a piece of paper in the firebox.
Smoke during burning	The room is at low pressure		In rooms with Controlled Mechanical Ventilation, leave an outdoor window ajar until the fire is fully alight.
	Too little wood loaded		Load as recommended. Loads notably smaller than those recommended lead to low smoke temperature and downdraught.
	Insufficient updraught		Check the condition of the flue and insulation. Check that the piping is not blocked. Clean mechanically if necessary
	Wind enters the flue		Install an anti-downdraught system (Cowl) at the top of the chimney
Does not warm up enough	The room is at low pressure		In rooms with Controlled Mechanical Ventilation, there must be an outdoor-air inlet
	Poor-quality wood		Only use the recommended fuel
Water condenses (after the appliance has been lit more than 3 or 4 times)	Too little wood loaded		Load as recommended. Loads notably smaller than those recommended lead to low smoke temperature and condensation.
	Green or damp wood		Use hard woods, cut at least 2 years ago and stored in a sheltered, ventilated place.
	Condition of the flue		Lengthen the flue (5-6 metres minimum). Insulate the flue properly. Check the airtightness of the flue/appliance.

6. BASIC BREAKDOWNS

Figure No.20 - Basic breakdowns

		Clasica 5T	Clasica 7T	Clasica 8T
Nº	Denom.	Ref.	Ref.	Ref.
1	Cristal Encimera Vitro	501000000126	501000000124	501000000219
2	Protección grande con arandelas "esmaltadas"	-	-	501000000322 (1)
2	Protección mediana con arandelas "esmaltadas"	-	501000000323 (2)	501000000323 (1)
2	Protección pequeña con arandelas "esmaltadas"	501000000324 (2)	-	-
3	C.Cerrada Cajon Cenicero	501000000296	501000000296	501000000296
4	Cristal puerta Horno	501250000002	500000000038	500000000039
5	Cristal puerta Hogar	501250000045	501210000832	501210000832
6	Termometro horno Cromado	500000000033	500000000033	500000000033
6	Termometro horno Latón	500000000070	500000000070	500000000070
7	Fleje cierre puertas	501000000288	501000000288	501000000288
8	Cordón Puerta Horno Ø10 blanco 2m	500900000015	500900000015	500900000015
8	Cordón Puerta Hogar (2 metros Ø10 blanco)	500900000015	500900000015	500900000015
9	Soporte+Sujección barra Izdo Crom.	501000000868	501000000868	501000000868
9	Soporte+Sujección barra Izdo Laton	501000000866	501000000866	501000000866
10	Soporte+Sujección barra Dcho Cromado	501000000869	501000000869	501000000869
10	Soporte+Sujección barra Dcho Latón	501000000867	501000000867	501000000867
11	Barra Cromada	500000000050	501220000001	500000000024
11	Barra Latón	508020000001	508060000001	508070000001
12	Bandeja esmaltada	501000000002	501000000002	500000000045
13	Bandeja varilla	501000000004	501000000004	501230000002
14	CLASICA eco, Vermiculita trasera hogar	5012500047	5012100838	5012100838
15	Refractario hogar Derecho (Delantero-Trasero)	501210000004	501210000004	501210000004
16	Refractario hogar izquierdo (Delantero-Trasero)	501210000003	501210000003	501210000003
17	Juego completo refractario hogar	5012500048	5012100839	5012100839
18	Parrilla hogar	501250000004	501000000904	501000000904
19	Varilla tiro directo	501210000028	501210000028	501210000028
20	Bisagra latón	500000000058	500000000058	500000000058
20	Bisagra cromada	500000000057	500000000057	500000000057
21	Manilla latón	501250000039	500000000052	500000000052
21	Manilla cromada	501250000019	500000000053	500000000053
22	Clasica Chapa Inox. Sujec. Refractarios	501000000307	501000000307	501000000307
23	CLASICA eco, Chapa trasera hogar	5012500049	5012100840	5012100840
24	CLASICA eco, Vermiculita Superior Hogar	5012500050	5012100841	5012100841

7. PRODUCT RECYCLING

The recycling of the appliance is the exclusive responsibility of the owner, who must act in compliance with the laws in force in his country regarding safety, respect and protection of the environment. At the end of its useful life, the product must not be disposed of with urban waste.

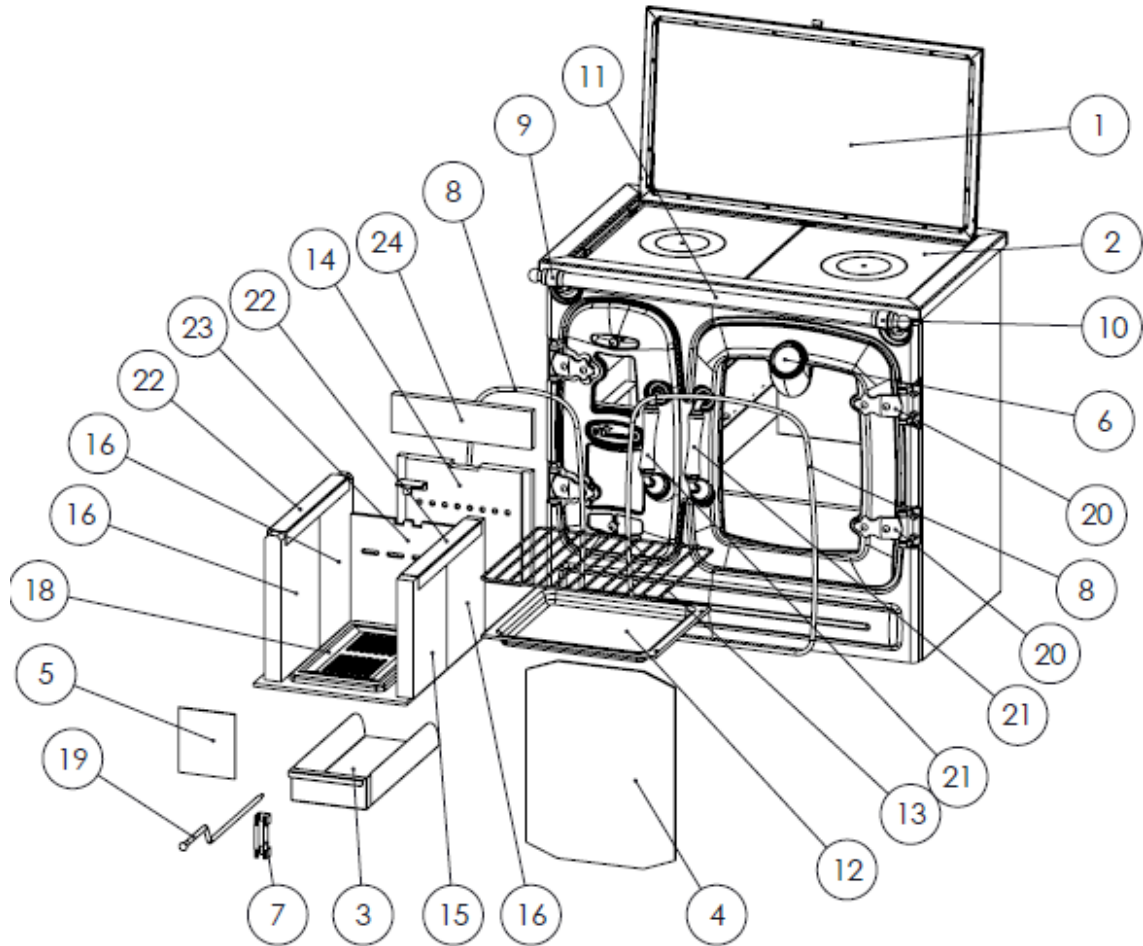
It can be delivered to the specific selective collection centres set up by the municipalities, or to retailers who offer this service. The selective disposal of the product avoids possible negative consequences for the environment and for health and makes it possible to recover the materials of which it is composed, thus obtaining significant savings in terms of energy and resources.

It can be disassembled (the parts are assembled with screws or rivets) and the components can be deposited in their corresponding recycling channels. The components of the appliance are: steel, cast iron, glass, insulating materials, electrical material, etc.

8. DECLARATION OF PERFORMANCE



CO-S-004

DECLARACIÓN DE PRESTACIONES Conforme al R. E. Productos Construcción (UE) Nº 305/2011**DÉCLARATION DE PERFORMANCE** Selon le Règlement (UE) Nº 305/2011**DICHIARAZIONE DI PRESTAZIONE** In base al Regolamento (UE) Nº 305/2011**DECLARATION OF PERFORMANCE** According to Regulation (UE) Nº 305/2011**DECLARAÇÃO DE PRESTAÇÕES** Em base com o Regulamento (UE) Nº 305/2011

- Nombre y/o código de identificación única del producto:
Nom-code d'identification unique du produit
Nome-codice identificativo unico del prodotto
Unique identifier nome-code for product
Nome-código de identificação único do produto
 - Marca, marque, marca, mark, marca: **Lacunza**
 - Tipo, type, tipo, type, tipo: **Cocina, Cuisinière, Cucina, Cooker, Cozinha**
 - Modelo, modèle, modello, model, modelo: **CLASICA 5T**
- Uso o usos previstos del producto:** Cocina de carga manual, para quemar combustibles sólidos (indicado en instrucciones), cuya función es calentar el espacio en el que está instalada.
Utilisation prévue du produit: Cuisinière qui se charge manuellement, conçu pour brûler des combustibles solides (indiqués dans le Manuel d'Instructions), dont la fonction est de chauffer l'espace où il est installé.
Usi previsti del prodotto: Cucina a carico manuale, per bruciare combustibili solidi (indicati nelle istruzioni), la cui funzione è riscaldare lo spazio in cui è installato.
Intended uses of the product: Kitchen stove to be loaded by hand and designed to burn solid fuels (indicated in instructions), whose function is to heat the space in which it is installed.
Utilização prevista do produto: Cozinha de carga manual, para queimar combustíveis sólidos (indicado nas instruções), cuja função é aquecer o espaço no qual está instalado.
- Nombre y dirección del fabricante: **LACUNZA KALOR GROUP S.A.L.**
Nom et adresse du fabricant: **Pol. Ind. Ibarrea 5A 31800 Alsasua (Navarra) (España)**
Nome e indirizzo del fabbricante: **Téléfono: (0034) 948563511**
Name and address of the manufacturer: **Fax: (0034) 948563505**
Nome e endereço do fabricante: **Email: comercial@lacunza.net**
- Sistema de evaluación y verificación de la constancia de las prestaciones: **3**
Système d'évaluation et contrôle de la constante de performance: **3**
Sistema di valutazione e verifica della costanza della prestazione: **3**
Assessment and verification system for constancy of performance: **3**
Sistema de avaliação e verificação da regularidade do desempenho: **3**
- Organismo Notificado, Laboratoire notifié, Laboratorio notificato, Laboratory notified, Laboratório notificado:
STROJÍRENSKÝ ZKUŠEBNÍ ÚSTAV, S.P.
Engineering Test Institute, Public Enterprise
Hudcova 424/56b, 621 00 Brno, Czech Republic. Notified Body 1015
Por el sistema, Selon le system, In base al system, Based on system, Em base ao system : **3.**
Documento emitido (fecha), Numéro du rapport d'essai (date), Numero rapporto di prova (data), Test report number (date), Número relação de prova (data): **CPR-B-01862-21 (09-11-2021)**

6. Prestaciones declaradas, Performance déclarée, Prestazioni dichiarate, Services declare, Desempenhos declarados:

Especificaciones técnicas armonizadas, Spécifications techniques armonices, Specifica tecnica armonizzata, Harmonised technical specifications, Especifica técnica harmonizada EN12815:2001/A1:2004/AC:2006/AC:2007											
Características esenciales, Caractéristiques essentielles, Caratteristiche essenziali, Essential features, Características essenciais	Prestaciones, Performance, Prestazione, Services, Desempenho										
Reacción al fuego, Resistance au feu, Resistenza al fuoco, Resistance to fire, Resistência ao fogo	Cumple, Conforme, Conforme, Compliant, Em Conformidade										
Distancia mínima de seguridad a materiales combustibles, Distance minimum aux matériaux combustibles, Dintanza mínima da materiali combustibili, Minimum distance from combustible material, Distância mínimo de materiais combustíveis	<table border="1"> <tr> <td>Izquierda, gauche, sinistra, left, esquerda:</td> <td>200mm</td> </tr> <tr> <td>Derecha, droite, diritto, right, direito:</td> <td>200mm</td> </tr> <tr> <td>Trasera, arrière, retro, back, traseira:</td> <td>200mm</td> </tr> <tr> <td>Delantera, avant, fronte, front, frente:</td> <td>200mm</td> </tr> <tr> <td>Encimera, dessus, sopra, above, acima:</td> <td>800mm</td> </tr> </table>	Izquierda, gauche, sinistra, left, esquerda:	200mm	Derecha, droite, diritto, right, direito:	200mm	Trasera, arrière, retro, back, traseira:	200mm	Delantera, avant, fronte, front, frente:	200mm	Encimera, dessus, sopra, above, acima:	800mm
Izquierda, gauche, sinistra, left, esquerda:	200mm										
Derecha, droite, diritto, right, direito:	200mm										
Trasera, arrière, retro, back, traseira:	200mm										
Delantera, avant, fronte, front, frente:	200mm										
Encimera, dessus, sopra, above, acima:	800mm										
Temperatura humos a potencia térmica nominal, Température des fumées, Temperatura fumi, Fume temperatura, Temperatura dos gases de combustão	175 °C										
Emisión, Emission, Emissione, Emissão, Emission, CO 13% O2	0,09 %										
Emisión, Emission, Emissione, Emissão, Emission, CO 13% O2	1155 mg/Nm ³										
Emisión, Emission, Emissione, Emissão, Emission, NOx 13% O2	159 mg/Nm ³										
Emisión, Emission, Emissione, Emissão, Emission, OGC 13% O2	82 mg/Nm ³										
Emisión, Emission, Emissione, Emissão, Emission, PM 13% O2	31 mg/Nm ³										
Desprendimiento de sustancias peligrosas, Rejet de substances dangereuses, Rilascio di sostanze pericolose, Release of hazardous substances, Lançamento de substâncias perigosas	Cumple, Conforme, Conforme, Compliant, Em Conformidade										
Temperatura superficial, Température de surface, Temperatura superficiale, Surface temperatura, Temperatura superficial	Cumple, Conforme, Conforme, Compliant, Em Conformidade										
Seguridad eléctrica, Sécurité électrique, Sicurezza elettrica, Electrical safety, Segurança elétrica	-										
Presión máxima de servicio (agua), Pression maximale de service, Máxima pressione di esercizio, Maximun operating pressure, Máxima pressão de exercício	-										
Resistencia mecánica (para soportar una chimenea/un conducto de humos), Resistanse mécanique (pour soutenir la cheminée), Resistenza mecánica (per supportare il camino), Mechanical strength (to support the fireplace), Resistência mecânica (para suportar a chaminé)	Cumple, Conforme, Conforme, Compliant, Em Conformidade										
Potencia térmica ambiente, Puissance rendue au milieu, Potenza resa all'ambiente, Power output to the environment, Potência libertada no ambiente	10 kW										
Potencia térmica agua, Puissance rendue à l'eau, Potenza ceduta all'acqua, Power transferred to wáter, Potência cedida à água	-										
Rendimiento energético, Rendement, Rendimento, Efficiency, Atuação	85 %										

Las prestaciones del producto identificado en el punto 1 son conformes con las prestaciones declaradas en el punto 6.
 La performance du produit citée au point 1 est conforme à la performance declare au point 6.
 La prestazione del prodotto di cui ai punti 1 è conforme alla prestazione dichiarata di cui al punto 6.
 The performance of the product referred to in point 1 is consistent with the declared performance in point 6.
 As declarações do produto identificado no ponto 1, estão conformes com as prestações declaradas no ponto 6.

La presente declaración de prestaciones se emite bajo la única responsabilidad del fabricante, indicado en el punto 3.
 Cette déclaration de performance est délivrée sous la responsabilité exclusive du fabricant cité au point 3.
 Si rilascia la presente dichiarazione di prestazione sotto la responsabilità esclusiva del fabricante di cui al punto 3.
 This declaration of performance is issued under the manufacturer's sole responsibility referred to in point 3.
 É emitida a presente declaração de desempenho sob a responsabilidade exclusiva do fabricante referido no ponto 3.



José Julián Garcandía Pellejero
 Director Gerente

Alsasua 10-01-2022



CO-S-005

DECLARACIÓN DE PRESTACIONES Conforme al R. E. Productos Construcción (UE) Nº 305/2011**DÉCLARATION DE PERFORMANCE** Selon le Règlement (UE) Nº 305/2011**DICHIARAZIONE DI PRESTAZIONE** In base al Regolamento (UE) Nº 305/2011**DECLARATION OF PERFORMANCE** According to Regulation (UE) Nº 305/2011**DECLARAÇÃO DE PRESTAÇÕES** Em base com o Regulamento (UE) Nº 305/2011

- Nombre y/o código de identificación única del producto:
Nom-code d'identification unique du produit
Nome-codice identificativo unico del prodotto
Unique identifier nome-code for product
Nome-código de identificação único do produto
 - Marca, marque, marca, mark, marca: **Lacunza**
 - Tipo, type, tipo, type, tipo: **Cocina, Cuisinière, Cucina, Cooker, Cozinha**
 - Modelo, modèle, modello, model, modelo: **CLASICA 7T**
- Uso o usos previstos del producto:** Cocina de carga manual, para quemar combustibles sólidos (indicado en instrucciones), cuya función es calentar el espacio en el que está instalada.
Utilisation prévue du produit: Cuisinière qui se charge manuellement, conçu pour brûler des combustibles solides (indiqués dans le Manuel d'Instructions), dont la fonction est de chauffer l'espace où il est installé.
Usi previsti del prodotto: Cucina a carico manuale, per bruciare combustibili solidi (indicati nelle istruzioni), la cui funzione è riscaldare lo spazio in cui è installato.
Intended uses of the product: Kitchen stove to be loaded by hand and designed to burn solid fuels (indicated in instructions), whose function is to heat the space in which it is installed.
Utilização prevista do produto: Cozinha de carga manual, para queimar combustíveis sólidos (indicado nas instruções), cuja função é aquecer o espaço no qual está instalado.
- Nombre y dirección del fabricante: **LACUNZA KALOR GROUP S.A.L.**
Nom et adresse du fabricant: **Pol. Ind. Ibarrea 5A 31800 Alsasua (Navarra) (España)**
Nome e indirizzo del fabbricante: **Télefono: (0034) 948563511**
Name and address of the manufacturer: **Fax: (0034) 948563505**
Nome e endereço do fabricante: **Email: comercial@lacunza.net**
- Sistema de evaluación y verificación de la constancia de las prestaciones: **3**
Système d'évaluation et contrôle de la constante de performance: **3**
Sistema di valutazione e verifica della costanza della prestazione: **3**
Assessment and verification system for constancy of performance: **3**
Sistema de avaliação e verificação da regularidade do desempenho: **3**
- Organismo Notificado, Laboratoire notifié, Laboratorio notificato, Laboratory notified, Laboratório notificado:
STROJÍRENSKÝ ZKUŠEBNÍ ÚSTAV, S.P.
Engineering Test Institute, Public Enterprise
Hudcova 424/56b, 621 00 Brno, Czech Republic. Notified Body 1015
Por el sistema, Selon le system, In base al system, Based on system, Em base ao system : **3**.
Documento emitido (fecha), Numéro du rapport d'essai (date), Numero rapporto di prova (data), Test report number (date), Número relação de prova (data): **CPR-B-01862-21 (09-11-2021)**

6. Prestaciones declaradas, Performance déclarée, Prestazioni dichiarate, Services declare, Desempenhos declarados:

Especificaciones técnicas armonizadas, Spécifications techniques armonices, Specifica tecnica armonizzata, Harmonised technical specifications, Especifica técnica harmonizada EN12815:2001/A1:2004/AC:2006/AC:2007											
Características esenciales, Caractéristiques essentielles, Caratteristiche essenziali, Essential features, Características essenciais	Prestaciones, Performance, Prestazione, Services, Desempenho										
Reacción al fuego, Resistance au feu, Resistenza al fuoco, Resistance to fire, Resistência ao fogo	Cumple, Conforme, Conforme, Compliant, Em Conformidade										
Distancia mínima de seguridad a materiales combustibles, Distance minimum aux matériaux combustibles, Distanza minima da materiali combustibili, Minimum distance from combustible material, Distância mínimo de materiais combustíveis	<table border="1"> <tr> <td>Izquierda, gauche, sinistra, left, esquerda:</td> <td>200mm</td> </tr> <tr> <td>Derecha, droite, diritto, right, direito:</td> <td>200mm</td> </tr> <tr> <td>Trasera, arrière, retro, back, traseira:</td> <td>200mm</td> </tr> <tr> <td>Delantera, avant, fronte, front, frente:</td> <td>200mm</td> </tr> <tr> <td>Encimera, dessus, sopra, above, acima:</td> <td>800mm</td> </tr> </table>	Izquierda, gauche, sinistra, left, esquerda:	200mm	Derecha, droite, diritto, right, direito:	200mm	Trasera, arrière, retro, back, traseira:	200mm	Delantera, avant, fronte, front, frente:	200mm	Encimera, dessus, sopra, above, acima:	800mm
Izquierda, gauche, sinistra, left, esquerda:	200mm										
Derecha, droite, diritto, right, direito:	200mm										
Trasera, arrière, retro, back, traseira:	200mm										
Delantera, avant, fronte, front, frente:	200mm										
Encimera, dessus, sopra, above, acima:	800mm										
Temperatura humos a potencia térmica nominal, Température des fumées, Temperatura fumi, Fume temperatura, Temperatura dos gases de combustão	175 °C										
Emisión, Emission, Emissione, Emissão, Emission, CO 13% O2	0,09 %										
Emisión, Emission, Emissione, Emissão, Emission, CO 13% O2	1155 mg/Nm ³										
Emisión, Emission, Emissione, Emissão, Emission, NOx 13% O2	174 mg/Nm ³										
Emisión, Emission, Emissione, Emissão, Emission, OGC 13% O2	82 mg/Nm ³										
Emisión, Emission, Emissione, Emissão, Emission, PM 13% O2	31 mg/Nm ³										
Desprendimiento de sustancias peligrosas, Rejet de substances dangereuses, Rilascio di sostanze pericolose, Release of hazardous substances, Lançamento de substâncias perigosas	Cumple, Conforme, Conforme, Compliant, Em Conformidade										
Temperatura superficial, Température de surface, Temperatura superficiale, Surface temperatura, Temperatura superficial	Cumple, Conforme, Conforme, Compliant, Em Conformidade										
Seguridad eléctrica, Sécurité électrique, Sicurezza elettrica, Electrical safety, Segurança elétrica	-										
Presión máxima de servicio (agua), Pression maximale de service, Máxima pressione di esercizio, Maximun operating pressure, Máxima pressão de exercício	-										
Resistencia mecánica (para soportar una chimenea/un conducto de humos), Resistance mécanique (pour soutenir la cheminée), Resistenza mecánica (per supportare il camino), Mechanical strength (to support the fireplace), Resistência mecânica (para suportar a chaminé)	Cumple, Conforme, Conforme, Compliant, Em Conformidade										
Potencia térmica ambiente, Puissance rendue au milieu, Potenza resa all'ambiente, Power output to the environment, Potência libertada no ambiente	11 kW										
Potencia térmica agua, Puissance rendue à l'eau, Potenza ceduta all'acqua, Power transferred to water, Potência cedida à água	-										
Rendimiento energético, Rendement, Rendimento, Efficiency, Atuação	85 %										

Las prestaciones del producto identificado en el punto 1 son conformes con las prestaciones declaradas en el punto 6.
 La performance du produit citée au point 1 est conforme à la performance declare au point 6.
 La prestazione del prodotto di cui ai punti 1 è conforme alla prestazione dichiarata di cui al punto 6.
 The performance of the product referred to in point 1 is consistent with the declared performance in point 6.
 As declarações do produto identificado no ponto 1, estão conformes com as prestações declaradas no ponto 6.

La presente declaración de prestaciones se emite bajo la única responsabilidad del fabricante, indicado en el punto 3.
 Cette déclaration de performance est délivrée sous la responsabilité exclusive du fabricant cité au point 3.
 Si rilascia la presente dichiarazione di prestazione sotto la responsabilità esclusiva del fabricante di cui al punto 3.
 This declaration of performance is issued under the manufacturer's sole responsibility referred to in point 3.
 É emitida a presente declaração de desempenho sob a responsabilidade exclusiva do fabricante referido no ponto 3.



José Julián Garcandía Pellejero
 Director Gerente

Alsasua 10-01-2022



CO-S-006

DECLARACIÓN DE PRESTACIONES Conforme al R. E. Productos Construcción (UE) Nº 305/2011**DÉCLARATION DE PERFORMANCE** Selon le Règlement (UE) Nº 305/2011**DICHIARAZIONE DI PRESTAZIONE** In base al Regolamento (UE) Nº 305/2011**DECLARATION OF PERFORMANCE** According to Regulation (UE) Nº 305/2011**DECLARAÇÃO DE PRESTAÇÕES** Em base com o Regulamento (UE) Nº 305/2011

- Nombre y/o código de identificación única del producto:
Nom-code d'identification unique du produit
Nome-codice identificativo unico del prodotto
Unique identifier nome-code for product
Nome-código de identificação único do produto
 - Marca, marque, marca, mark, marca: **Lacunza**
 - Tipo, type, tipo, type, tipo: **Cocina, Cuisinière, Cucina, Cooker, Cozinha**
 - Modelo, modèle, modello, model, modelo: **CLASICA 8T**
- Us o usos previstos del producto:** Cocina de carga manual, para quemar combustibles sólidos (indicado en instrucciones), cuya función es calentar el espacio en el que está instalada.
Utilisation prévue du produit: Cuisinière qui se charge manuellement, conçu pour brûler des combustibles solides (indiqués dans le Manuel d'Instructions), dont la fonction est de chauffer l'espace où il est installé.
Usi previsti del prodotto: Cucina a carico manuale, per bruciare combustibili solidi (indicati nelle istruzioni), la cui funzione è riscaldare lo spazio in cui è installato.
Intended uses of the product: Kitchen stove to be loaded by hand and designed to burn solid fuels (indicated in instructions), whose function is to heat the space in which it is installed.
Utilização prevista do produto: Cozinha de carga manual, para queimar combustíveis sólidos (indicado nas instruções), cuja função é aquecer o espaço no qual está instalado.
- Nombre y dirección del fabricante: **LACUNZA KALOR GROUP S.A.L.**
Nom et adresse du fabricant: **Pol. Ind. Ibarrea 5A 31800 Alsasua (Navarra) (España)**
Nome e indirizzo del fabbricante: **Téléfono: (0034) 948563511**
Name and adress of the manufacturer: **Fax: (0034) 948563505**
Nome e endereço do fabricante: **Email: comercial@lacunza.net**
- Sistema de evaluación y verificación de la constancia de las prestaciones: **3**
Système d'évaluation et contrôle de la constante de performance: **3**
Sistema di valutazione e verifica della costanza della prestazione: **3**
Assessment and verification system for constancy of performance: **3**
Sistema de avaliação e verificação da regularidade do desempenho: **3**
- Organismo Notificado, Laboratoire notifié, Laboratorio notificato, Laboratory notified, Laboratório notificado:
STROJIRENSKÝ ZKUŠEBNÍ ÚSTAV, S.P.
Engineering Test Institute, Public Enterprise
Hudcova 424/56b, 621 00 Brno, Czech Republic. Notified Body 1015
Por el sistema, Selon le system, In base al system, Based on system, Em base ao system : **3.**
Documento emitido (fecha), Numéro du rapport d'essai (date), Numero rapporto di prova (data), Test report number (date), Número relação de prova (data): **CPR-B-01862-21 (09-11-2021)**

6. Prestaciones declaradas, Performance déclarée, Prestazioni dichiarate, Services declare, Desempenhos declarados:

Especificaciones técnicas armonizadas, Spécifications techniques armonices, Specifica tecnica armonizzata, Harmonised technical specifications, Especifica técnica harmonizada EN12815:2001/A1:2004/AC:2006/AC:2007											
Características esenciales, Caractéristiques essentielles, Caratteristiche essenziali, Essential features, Características essenciais	Prestaciones, Performance, Prestazione, Services, Desempenho										
Reacción al fuego, Resistance au feu, Resistenza al fuoco, Resistance to fire, Resistência ao fogo	Cumple, Conforme, Conforme, Compliant, Em Conformidade										
Distancia mínima de seguridad a materiales combustibles, Distance minimum aux matériaux combustibles, Dintanza mínima da materiali combustibili, Minimum distance from combustible material, Distância mínimo de materiais combustíveis	<table border="1"> <tr> <td>Izquierda, gauche, sinistra, left, esquerda:</td> <td>200mm</td> </tr> <tr> <td>Derecha, droite, diritto, right, direito:</td> <td>200mm</td> </tr> <tr> <td>Trasera, arrière, retro, back, traseira:</td> <td>200mm</td> </tr> <tr> <td>Delantera, avant, fronte, front, frente:</td> <td>200mm</td> </tr> <tr> <td>Encimera, dessus, sopra, above, acima:</td> <td>800mm</td> </tr> </table>	Izquierda, gauche, sinistra, left, esquerda:	200mm	Derecha, droite, diritto, right, direito:	200mm	Trasera, arrière, retro, back, traseira:	200mm	Delantera, avant, fronte, front, frente:	200mm	Encimera, dessus, sopra, above, acima:	800mm
Izquierda, gauche, sinistra, left, esquerda:	200mm										
Derecha, droite, diritto, right, direito:	200mm										
Trasera, arrière, retro, back, traseira:	200mm										
Delantera, avant, fronte, front, frente:	200mm										
Encimera, dessus, sopra, above, acima:	800mm										
Temperatura humos a potencia térmica nominal, Température des fumées, Temperatura fumi, Fume temperatura, Temperatura dos gases de combustão	157 °C										
Emisión, Emission, Emissione, Emissão, Emission, CO 13% O2	0,08 %										
Emisión, Emission, Emissione, Emissão, Emission, CO 13% O2	969 mg/Nm ³										
Emisión, Emission, Emissione, Emissão, Emission, NOx 13% O2	174 mg/Nm ³										
Emisión, Emission, Emissione, Emissão, Emission, OGC 13% O2	75 mg/Nm ³										
Emisión, Emission, Emissione, Emissão, Emission, PM 13% O2	31 mg/Nm ³										
Desprendimiento de sustancias peligrosas, Rejet de substances dangereuses, Rilascio di sostanze pericolose, Release of hazardous substances, Lançamento de substâncias perigosas	Cumple, Conforme, Conforme, Compliant, Em Conformidade										
Temperatura superficial, Température de surface, Temperatura superficiale, Surface temperatura, Temperatura superficial	Cumple, Conforme, Conforme, Compliant, Em Conformidade										
Seguridad eléctrica, Sécurité électrique, Sicurezza elettrica, Electrical safety, Segurança elétrica	-										
Presión máxima de servicio (agua), Pression maximale de service, Máxima pressione di esercizio, Maximun operating pressure, Máxima pressão de exercício	-										
Resistencia mecánica (para soportar una chimenea/un conducto de humos), Resistance mécanique (pour soutenir la cheminée), Resistenza mecânica (per supportare il camino), Mechanical strength (to support the fireplace), Resistência mecânica (para suportar a chaminé)	Cumple, Conforme, Conforme, Compliant, Em Conformidade										
Potencia térmica ambiente, Puissance rendue au milieu, Potenza resa all'ambiente, Power output to the environment, Potência libertada no ambiente	12 kW										
Potencia térmica agua, Puissance rendue à l'eau, Potenza ceduta all'acqua, Power transferred to wáter, Potência cedida à água	-										
Rendimiento energético, Rendement, Rendimento, Efficiency, Atuação	85,3 %										

Las prestaciones del producto identificado en el punto 1 son conformes con las prestaciones declaradas en el punto 6.
 La performance du produit citée au point 1 est conforme à la performance declare au point 6.
 La prestazione del prodotto di cui ai punti 1 è conforme alla prestazione dichiarata di cui al punto 6.
 The performance of the product referred to in point 1 is consistent with the declared performance in point 6.
 As declarações do produto identificado no ponto 1, estão conformes com as prestações declaradas no ponto 6.

La presente declaración de prestaciones se emite bajo la única responsabilidad del fabricante, indicado en el punto 3.
 Cette déclaration de performance est délivrée sous la responsabilité exclusive du fabricant cité au point 3.
 Si rilascia la presente dichiarazione di prestazione sotto la responsabilità esclusiva del fabricante di cui al punto 3.
 This declaration of performance is issued under the manufacturer's sole responsibility referred to in point 3.
 É emitida a presente declaração de desempenho sob a responsabilidade exclusiva do fabricante referido no ponto 3.



Lacunza Kalor Group S.A.L.
 NIF A-31606932
 Polígono Industrial Ibarrea s/n
 31800 Alsasua (Navarra) Spain





José Julián Garcandía Pellejero
 Director Gerente

Alsasua 10-01-2022

9. CE MARK

	LACUNZA KALOR GROUP S.A.L. Pol. Ind. Ibarrea 5A 31800 Alsasua (Navarra) (Spain)
	Número, Nombre, Numero, Number, Número : CO-S-004
Marca, marque, marca, mark, marca: Lacunza Tipo, type, tipo, type, tipo: Cocina, Cuisinière, Cucina, Cooker, Cozinha Modelo, modèle, modello, model, modelo: CLASICA 5T	Organismo notificado, Laboratoire notifié, Laboratorio notificato, Laboratory notified, Laboratorio notificado: SZU Nº 1015
Aparato Tipo, Type d'appareil, Tipo di apparecchio, Apparatus Type, Tipo de aparelho: B	
<p>Cocina de carga manual, para quemar combustibles sólidos (indicado en instrucciones), cuya función es calentar el espacio en el que está instalada. Funcionamiento Intermitente. Para conducto humos no compartido.</p> <p>Cuisinière qui se charge manuellement, conçu pour brûler des combustibles solides (indiqués dans le Manuel d'Instructions), dont la fonction est de chauffer l'espace où il est installé. Fonctionnement intermittent. Pour conduit non partagé.</p> <p>Cucina a carico manuale, per bruciare combustibili solidi (indicati nelle istruzioni), la cui funzione è riscaldare lo spazio in cui è installato. Funzionamento intermittente. Per condotto non condiviso.</p> <p>Kitchen stove to be loaded by hand and designed to burn solid fuels (indicated in instructions), whose function is to heat the space in which it is installed. Intermittent operation. For non-shared conduit.</p> <p>Cozinha de carga manual, para queimar combustíveis sólidos (indicado nas instruções), cuja função é aquecer o espaço no qual está instalado. Operação intermitente. Para conduíte não compartilhado.</p>	
EN12815:2001/A1:2004/AC:2006/AC:2007	
Características esenciales, Caractéristiques essentielles, Caratteristiche essenziali, Essential features, Características essenciais	Prestaciones, Performance, Prestazione, Services, Desempenho
Reacción al fuego, Résistance au feu, Resistenza al fuoco, Resistance to fire, Resistência ao fogo	Cumple, Conforme, Conforme, Compliant, Em Conformidade
Distancia mínima de seguridad a materiales combustibles, Distance minimum aux matériaux combustibles, Dintanza minima da materiali combustibili, Minimum distance from combustible material, Distância mínimo de materiais combustíveis	Izquierda, gauche, sinistra, left, esquerda: 200mm Derecha, droite, diritto, right, direito: 200mm Trasera, arrière, retro, back, traseira: 200mm Delantera, avant, fronte, front, frente: 200mm Encimera, dessus, sopra, above, acima: 800mm
Temperatura humos a potencia térmica nominal, Température des fumées, Temperatura fumi, Fume temperatura, Temperatura dos gases de combustão	175 °C
Emisión productos combustión, Emisión des produits de combustion, Emisión prodotti combustione, Combustión productos emissions, Emissões de produtos de combustão	Cumple, Conforme, Conforme, Compliant, Em Conformidade
Emisión, Emission, Emissione, Emissão, Emission, CO 13% O2	0,09 %
Emisión, Emission, Emissione, Emissão, Emission, CO 13% O2	1155 mg/Nm³
Emisión, Emission, Emissione, Emissão, Emission, NOx 13% O2	159 mg/Nm³
Emisión, Emission, Emissione, Emissão, Emission, OGC 13% O2	82 mg/Nm³
Emisión, Emission, Emissione, Emissão, Emission, PM 13% O2	31 mg/Nm³
Desprendimiento de sustancias peligrosas, Rejet de substances dangereuses, Rilascio di sostanze pericolose, Release of hazardous substances, Lançamento de substâncias perigosas	Cumple, Conforme, Conforme, Compliant, Em Conformidade
Temperatura superficial, Température de surface, Temperatura superficiale, Surface temperatura, Temperatura superficial	Cumple, Conforme, Conforme, Compliant, Em Conformidade
Presión máxima de servicio (agua), Pression maximale de service, Máxima pressione di esercizio, Maximun operating pressure, Máxima pressão de exercício	-
Resistencia mecánica (para soportar una chimenea/un conducto de humos), Résistance mécanique (pour soutenir la cheminée), Resistenza mecánica (per supportare il camino), Mechanical strength (to support the fireplace), Resistência mecânica (para suportar a chaminé)	Cumple, Conforme, Conforme, Compliant, Em Conformidade
Potencia térmica ambiente, Puissance rendue au milieu, Potenza resa all'ambiente, Power output to the environment, Potência libertada no ambiente	10 kW
Potencia térmica agua, Puissance rendue à l'eau, Potenza ceduta all'acqua, Power transferred to wáter, Potência cedida à água	-
Rendimiento energético, Rendement, Rendimento, Efficiency, Atuação	85 %

 05	LACUNZA KALOR GROUP S.A.L. Pol. Ind. Ibarrea 5A 31800 Alsasua (Navarra) (Spain)	
	Número, Nombre, Numero, Number, Número : CO-S-005	
Marca, marque, marca, mark, marca: Lacunza Tipo, type, tipo, type, tipo: Cocina, Cuisinière, Cucina, Cooker, Cozinha Modelo, modèle, modello, model, modelo: CLASICA 7T	Organismo notificado, Laboratoire notifié, Laboratorio notificato, Laboratory notified, Laboratorio notificado: SZU Nº 1015	
Aparato Tipo, Type d'appareil, Tipo di apparecchio, Apparatus Type, Tipo de aparelho: B		
<p>Cocina de carga manual, para quemar combustibles sólidos (indicado en instrucciones), cuya función es calentar el espacio en el que está instalada. Funcionamiento Intermitente. Para conducto humos no compartido.</p> <p>Cuisinière qui se charge manuellement, conçu pour brûler des combustibles solides (indiqués dans le Manuel d'Instructions), dont la fonction est de chauffer l'espace où il est installé. Fonctionnement intermittent. Pour conduit non partagé.</p> <p>Cucina a carico manuale, per bruciare combustibili solidi (indicati nelle istruzioni), la cui funzione è riscaldare lo spazio in cui è installato. Funzionamento intermittente. Per condotto non condiviso.</p> <p>Kitchen stove to be loaded by hand and designed to burn solid fuels (indicated in instructions), whose function is to heat the space in which it is installed. Intermittent operation. For non-shared conduit.</p> <p>Cozinha de carga manual, para queimar combustíveis sólidos (indicado nas instruções), cuja função é aquecer o espaço no qual está instalado. Operação intermitente. Para conduíte não compartilhado.</p>		
EN12815:2001/A1:2004/AC:2006/AC:2007		
Características esenciales, Caractéristiques essentielles, Caratteristiche essenziali, Essential features, Características essenciais		Prestaciones, Performance, Prestazione, Services, Desempenho
Reacción al fuego, Résistance au feu, Resistenza al fuoco, Resistance to fire, Resistência ao fogo		Cumple, Conforme, Conforme, Compliant, Em Conformidade
Distancia mínima de seguridad a materiales combustibles, Distance minimum aux matériaux combustibles, Dintanza minima da materiali combustibili, Minimum distance from combustible material, Distância mínimo de materiais combustíveis	Izquierda, gauche, sinistra, left, esquerda: 200mm Derecha, droite, diritto, right, direito: 200mm Trasera, arrière, retro, back, traseira: 200mm Delantera, avant, frente, front, frente: 200mm Encimera, dessus, sopra, above, acima: 800mm	
Temperatura humos a potencia térmica nominal, Température des fumées, Temperatura fumi, Fume temperatura, Temperatura dos gases de combustão	175 °C	
Emisión productos combustión, Emisión des produits de combustion, Emisión prodotti combustione, Combustión productos emisiones, Emissões de produtos de combustão	Cumple, Conforme, Conforme, Compliant, Em Conformidade	
Emisión, Emission, Emissione, Emissão, Emission, CO 13% O2	0,09 %	
Emisión, Emission, Emissione, Emissão, Emission, CO 13% O2	1155 mg/Nm³	
Emisión, Emission, Emissione, Emissão, Emission, NOx 13% O2	174 mg/Nm³	
Emisión, Emission, Emissione, Emissão, Emission, OGC 13% O2	82 mg/Nm³	
Emisión, Emission, Emissione, Emissão, Emission, PM 13% O2	31 mg/Nm³	
Desprendimiento de sustancias peligrosas, Rejet de substances dangereuses, Rilascio di sostanze pericolose, Release of hazardous substances, Lançamento de substâncias perigosas	Cumple, Conforme, Conforme, Compliant, Em Conformidade	
Temperatura superficial, Température de surface, Temperatura superficiale, Surface temperatura, Temperatura superficial	Cumple, Conforme, Conforme, Compliant, Em Conformidade	
Presión máxima de servicio (agua), Pression maximale de service, Máxima pressione di esercizio, Maximum operating pressure, Máxima pressão de exercício	-	
Resistencia mecánica (para soportar una chimenea/un conducto de humos), Résistance mécanique (pour soutenir la cheminée), Resistenza mecánica (per supportare il camino), Mechanical strength (to support the fireplace), Resistência mecânica (para suportar a chaminé)	Cumple, Conforme, Conforme, Compliant, Em Conformidade	
Potencia térmica ambiente, Puissance rendue au milieu, Potenza resa all'ambiente, Power output to the environment, Potência libertada no ambiente	11 kW	
Potencia térmica agua, Puissance rendue à l'eau, Potenza ceduta all'acqua, Power transferred to wáter, Potência cedida à água	-	
Rendimiento energético, Rendement, Rendimento, Efficiency, Atuação	85 %	

	LACUNZA KALOR GROUP S.A.L. Pol. Ind. Ibarrea 5A 31800 Alsasua (Navarra) (Spain)
	Número, Nombre, Numero, Number, Número : CO-S-006
Marca, marque, marca, mark, marca: Lacunza Tipo, type, tipo, type, tipo: Cocina, Cuisinière, Cucina, Cooker, Cozinha Modelo, modèle, modello, model, modelo: CLASICA 8T	Organismo notificado, Laboratoire notifié, Laboratorio notificato, Laboratory notified, Laboratorio notificado: SZU Nº 1015
Aparato Tipo, Type d'appareil, Tipo di apparecchio, Apparatus Type, Tipo de aparelho: B	
<p>Cocina de carga manual, para quemar combustibles sólidos (indicado en instrucciones), cuya función es calentar el espacio en el que está instalada. Funcionamiento Intermitente. Para conducto humos no compartido.</p> <p>Cuisinière qui se charge manuellement, conçu pour brûler des combustibles solides (indiqués dans le Manuel d'Instructions), dont la fonction est de chauffer l'espace où il est installé. Fonctionnement intermittent. Pour conduit non partagé.</p> <p>Cucina a carico manuale, per bruciare combustibili solidi (indicati nelle istruzioni), la cui funzione è riscaldare lo spazio in cui è installato. Funzionamento intermittente. Per condotto non condiviso.</p> <p>Kitchen stove to be loaded by hand and designed to burn solid fuels (indicated in instructions), whose function is to heat the space in which it is installed. Intermittent operation. For non-shared conduit.</p> <p>Cozinha de carga manual, para queimar combustíveis sólidos (indicado nas instruções), cuja função é aquecer o espaço no qual está instalado. Operação intermitente. Para conduíte não compartilhado.</p>	
EN12815:2001/A1:2004/AC:2006/AC:2007	
Características esenciales, Caractéristiques essentielles, Caratteristiche essenziali, Essential features, Características essenciais	
Reacción al fuego, Résistance au feu, Resistenza al fuoco, Resistance to fire, Resistência ao fogo	
Prestaciones, Performance, Prestazione, Services, Desempenho	
Cumple, Conforme, Conforme, Compliant, Em Conformidade	
Distancia mínima de seguridad a materiales combustibles, Distance minimum aux matériaux combustibles, Dintanza minima da material combustibili, Minimum distance from combustible material, Distância mínimo de materiais combustíveis	Izquierda, gauche, sinistra, left, esquerda: 200mm Derecha, droite, diritto, right, direito: 200mm Trasera, arrière, retro, back, traseira: 200mm Delantera, avant, frente, front, frente: 200mm Encimera, dessus, sopra, above, acima: 800mm
Temperatura humos a potencia térmica nominal, Température des fumées, Temperatura fumi, Fume temperatura, Temperatura dos gases de combustão	157 °C
Emisión productos combustión, Emisión des produits de combustion, Emisión prodotti combustione, Combustión productos emissions, Emissões de produtos de combustão	Cumple, Conforme, Conforme, Compliant, Em Conformidade
Emisión, Emission, Emissione, Emissão, Emission, CO 13% O2	0,08 %
Emisión, Emission, Emissione, Emissão, Emission, CO 13% O2	969 mg/Nm³
Emisión, Emission, Emissione, Emissão, Emission, NOx 13% O2	174 mg/Nm³
Emisión, Emission, Emissione, Emissão, Emission, OGC 13% O2	75 mg/Nm³
Emisión, Emission, Emissione, Emissão, Emission, PM 13% O2	31 mg/Nm³
Desprendimiento de sustancias peligrosas, Rejet de substances dangereuses, Rilascio di sostanze pericolose, Release of hazardous substances, Lançamento de substâncias perigosas	Cumple, Conforme, Conforme, Compliant, Em Conformidade
Temperatura superficial, Température de surface, Temperatura superficiale, Surface temperatura, Temperatura superficial	Cumple, Conforme, Conforme, Compliant, Em Conformidade
Presión máxima de servicio (agua), Pression maximale de service, Máxima pressione di esercizio, Maximum operating pressure, Máxima pressão de exercício	-
Resistencia mecánica (para soportar una chimenea/un conducto de humos), Résistance mécanique (pour soutenir la cheminée), Resistenza mecánica (per supportare il camino), Mechanical strength (to support the fireplace), Resistência mecânica (para suportar a chaminé)	Cumple, Conforme, Conforme, Compliant, Em Conformidade
Potencia térmica ambiente, Puissance rendue au milieu, Potenza resa all'ambiente, Power output to the environment, Potência libertada no ambiente	12 kW
Potencia térmica agua, Puissance rendue à l'eau, Potenza ceduta all'acqua, Power transferred to wáter, Potência cedida à água	-
Rendimiento energético, Rendement, Rendimento, Efficiency, Atuação	85,3 %

LACUNZA KALOR GROUP S.A.L

Pol. Ind. Ibarrea 5A

31800 Alsasua (Navarra) Spain

Tel.: (00 34) 948 56 35 11

Fax.: (00 34) 948 56 35 05

e-mail: comercial@lacunza.net

Website: www.lacunza.net

EDITION: 3

